



**GESI art** for  
**chefs**  
ITALIA**21**

# INDEX



25



23 GESSI 316

39 STELO

51 INEDITO



51



71 FISSO

75 SU & GIÚ

79 OFFICINE V

89 OFFICINE GESSI



73

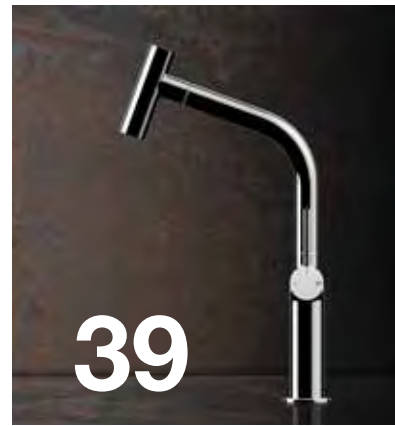

39

## GESSI art for chefs ITALIA21



83



112



97 MESH

107 INCISO



113 PROTON

125 JUST COLOR

131 ACCIAIO

137 HELLIUM

149 INCLINE

155 OXYGENE



163 SU & GIÚ

167 TRADIZIONE

171 MONACO

177 NEUTRON

187 CARY



195 SOAP DISPENSER

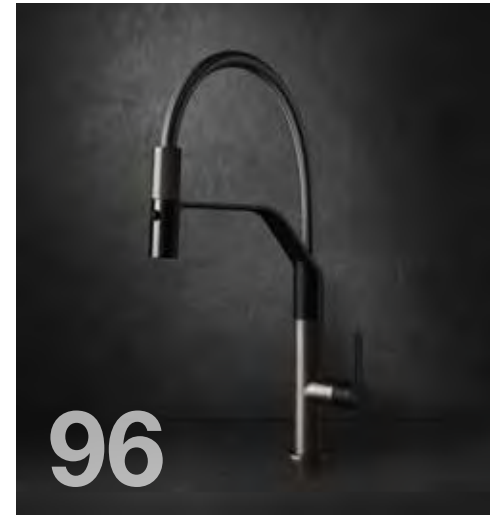

96



151

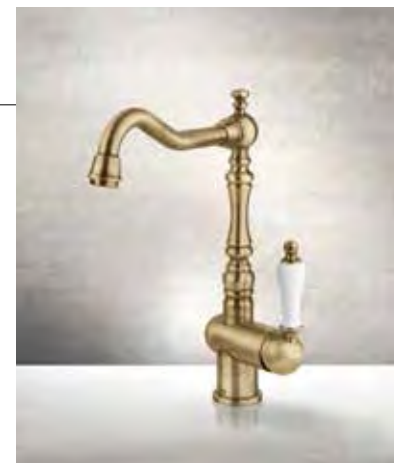



# A Family Story



## UNA STORIA DI FAMIGLIA

L'Azienda costituisce una storia di famiglia, iniziata nel 1992 dal genio dei fondatori Umberto Gessi e suo figlio Gian Luca. Essi hanno creduto nella missione di offrire un sostanziale Private Wellnes (benessere privato) attraverso prodotti dalla dirompente innovatività tecnologica e dallo stile design iconico. Negli ultimi anno Nicolò ed Emanuele, figli di Gian Luca, si sono uniti alla grande famiglia aziendale, che oggi comprende oltre 650 impiegati in tutto il mondo.

The company is a family story, born in 1992 from the genius of founders Umberto Gessi and his son Gian Luca, who believed in the mission of bringing a sense of private wellness through products with unprecedented technological innovation and iconic design style. In the recent times, Nicolò and Emanuele joined the family, who now comprises over 650 employees worldwide.

# Un'azienda di persone appassionate

## A COMPANY OF PASSIONATE PEOPLE

L'azienda è orgogliosa di avere al suo interno persone con un forte senso di appartenenza, un sentimento di inclusione che incrementa il coinvolgimento e il proprio valore personale nell'attività che ogni giorno si svolge all'interno di quella che è la Famiglia Gessi. Per questa ragione si prende cura di tutte le persone che fanno parte raverso anche un impegno sostanziale in tutto caratterizzano il successo.

The company is proud to have people with a strong sense of belonging, a feeling of inclusion that increases the involvement and personal value in the activity that takes place every day in the Gessi Family. Gessi does take care of all the people who are part of this reality, through a substantial commitment on the local territory, with welfare initiatives that characterize its success.



# Gessi, the Green Company

Gessi è fortemente radicata nel proprio territorio e fin dalla propria costituzione ha assunto la missione di rispettarlo. La fabbrica è circondata da 800.000 mq di parco verde, e si caratterizza per impianti di illuminazione ad alta efficienza, sistemi ventilati di raffreddamento e pannelli di riscaldamento ecologici, un impianto di riciclo totale dell'acqua, 4 ettari di pannelli fotovoltaici che producono energia pulita a favore delle operazioni produttive, evitando qualunque emissione di CO2.

Gessi belongs to its territory and since its inception has a mission to respect it. The factory, surrounded by 800.000smq of park, features high-efficiency lighting, ventilated eco-thermal panel systems, water recycling system, 4 hectares of photovoltaic panels that produce clean energy fuelling the workshop, avoiding any CO2 from emission.





## 100% made in Gessi

Gessi mantiene forti radici nel proprio territorio e realizza ogni fase della produzione in casa, assicurandosi in questo modo che il 100% dei componenti di prodotto sia made in Europe. L'Azienda vanta altissimi standard di tecnologia che assicurano la più alta qualità di prodotto.

Gessi maintains strong roots in its home territory and carries out each production phase in-house, ensuring 100% of its product components are made in Europe. The Company boasts high levels standards of technology, ensuring the highest standards of product quality.



## TECHNOLOGY AND INNOVATION Tecnologia e innovazione

Gessi crede nel miglioramento continuo, motivo per cui l'Azienda investe in R&S più del 10% dei profitti annuali, con l'obiettivo di alimentare l'innovazione tecnologica e tenere la fabbrica all'avanguardia. Siamo dotati di un team di 25 persone che lavorano sulla R&S di nuovi materiali, innovazione di processo, certificazioni e miglioramento continuo della qualità.

Gessi believes in continuous improvement, that is why the company invests in R&D over 10% of our profits every year to fuel technological innovation and upgrade our factory. We have an internal team of 25 people working on product R&D, new materials, process innovation, certifications and quality improvement.



# Massimo livello di servizio, pre e post vendita

MAXIMUM LEVEL OF SERVICE, BEFORE AND AFTER SALES

## IL MIGLIOR SERVIZIO DI PROFESSIONISTI A TUA DISPOSIZIONE

Professionalità, competenza e vicinanza al Cliente sono da sempre elementi distintivi del Customer Care Gessi. La più performante rete di professionisti del settore messa la servizio del Cliente in tutto il territorio nazionale con 27 Centri Tecnici Autorizzati.

Tutte le richieste sono gestite con l'attenzione e la competenza di chi è presente nelle case degli italiani da 30 anni.



Scansiona il QrCode e collegati a [www.gessi.com/it/contatti](http://www.gessi.com/it/contatti) alla sezione Assistenza Tecnica per visualizzare la rete dei centri assistenza Italia.

Scan the QrCode and connect to [www.gessi.com/it/contatti](http://www.gessi.com/it/contatti) in the Technical Assistance section to view the network of Italian assistance centers.



THE BEST SERVICE FROM PROFESSIONALS AT YOUR DISPOSAL

PRODUCT QUALITY AND GUARANTEE

## Qualità e Garanzia del prodotto

Professionalism, competence and closeness to the Customer have always been distinctive elements of Gessi Customer Care. The most performing network of professionals in the sector serving the customer throughout the national territory with 27 Authorized Technical Centers. All requests are handled with the attention and competence of those who have been present in Italian homes for 30 years.

The Gessi integrated quality and environmental management system is a guarantee of quality: our unique production method is certified UNI EN ISO 9001 since 1996.

100% of our production undergoes over decades of quality controls before being shipped to our customers, to ensure we deliver only the best. We strive for maximum excellence, that is why our portfolio achieved conformity certificates from the world's most renowned certification bodies.

Il Sistema Gessi di Qualità Integrata e di Gestione Ambientale, è una garanzia di qualità assoluta: il nostro speciale metodo di produzione è certificato UNI En ISO 9001 findal 1996. Il 100% della produzione è soggetto a scrupolosissimi controlli di qualità prima di essere consegnato ai nostri clienti, in modo da assicurarci di offrire solo il meglio. Noi siamo impegnati nel conseguimento della massima eccellenza, il che spiega perchè il nostro portfolio abbia conseguito certificazioni di conformità dagli organi di certificazione più importanti e rinomati del mondo.



# Gessi branches in the world.



- Canada
- USA
- Latino America
- Spain
- UK
- France
- Benelux
- Germany
- Austria
- Switzerland

- Italy
- Ukraine
- MEA
- Russia
- India
- China
- Hongkong
- Thailand
- Singapore
- Australia



## Casa Gessi

Innovative concept stores in which the Gessi philosophy, emotion and style can be experienced

### Gessi Milano

Via Manzoni 16A  
20121 Mailand - Italien

### Gessi Boutique Dubai

Al Quoz Industrial Area 1  
Street 2A, Dubai, UAE

### Casa Gessi Singapore

165 Penang Road  
238465 Singapur

### Casa Gessi London

Old Sessions House  
4 Farringdon Ln  
EC1R 0DU London – UK

### Casa Gessi Löhne

Weidengrüd 10  
32584 Löhne  
Deutschland

### Casa Gessi Riyadh

D Square est Al Mohammadiyah  
7060 Takassusi street, 12362,  
Riad Saudi Arabien



# COLLECTION

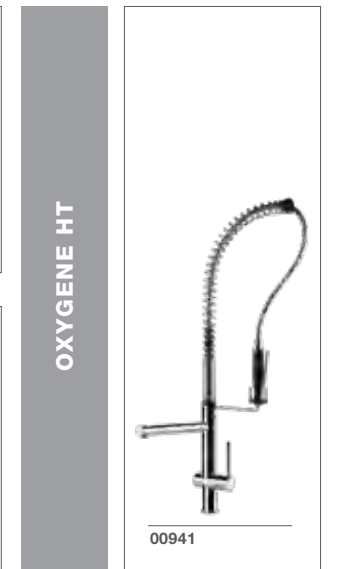
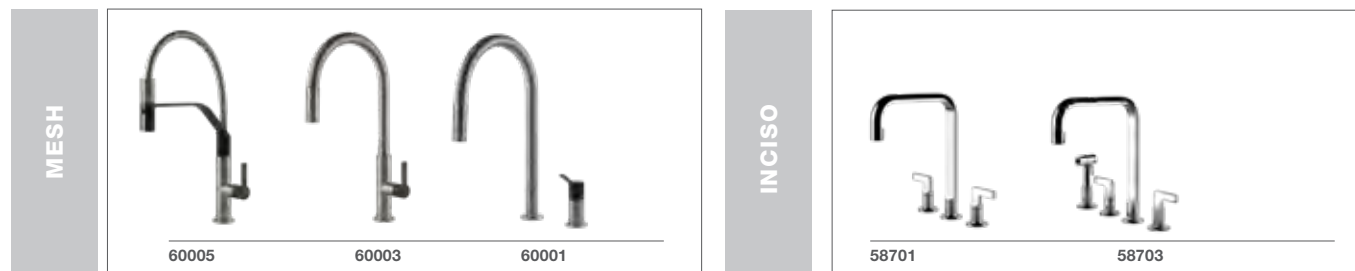
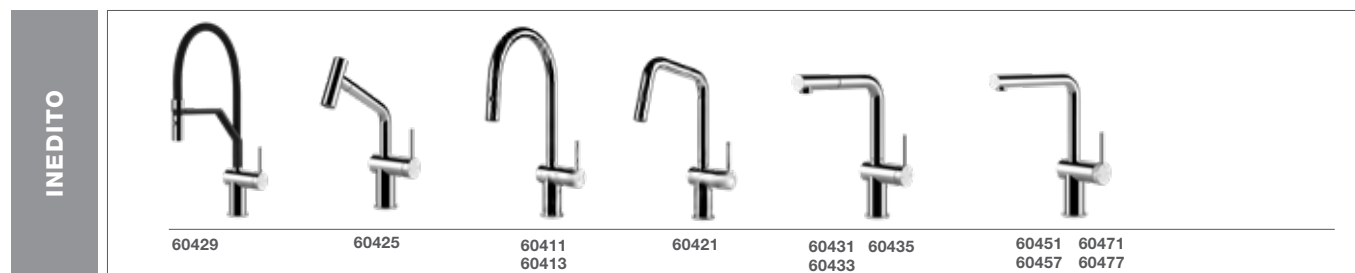
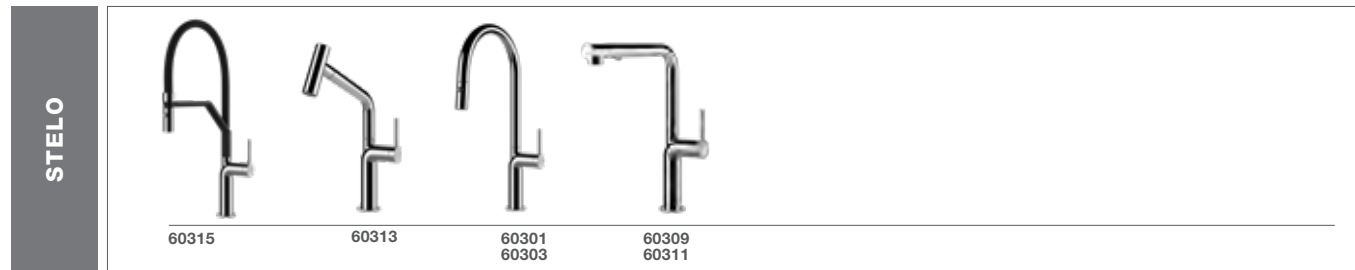
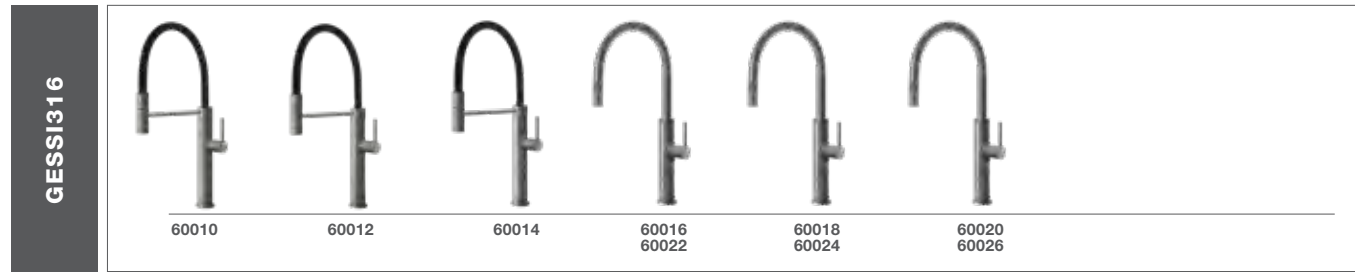

# SHAPE CONCEPT

PROFESSIONAL TAPS

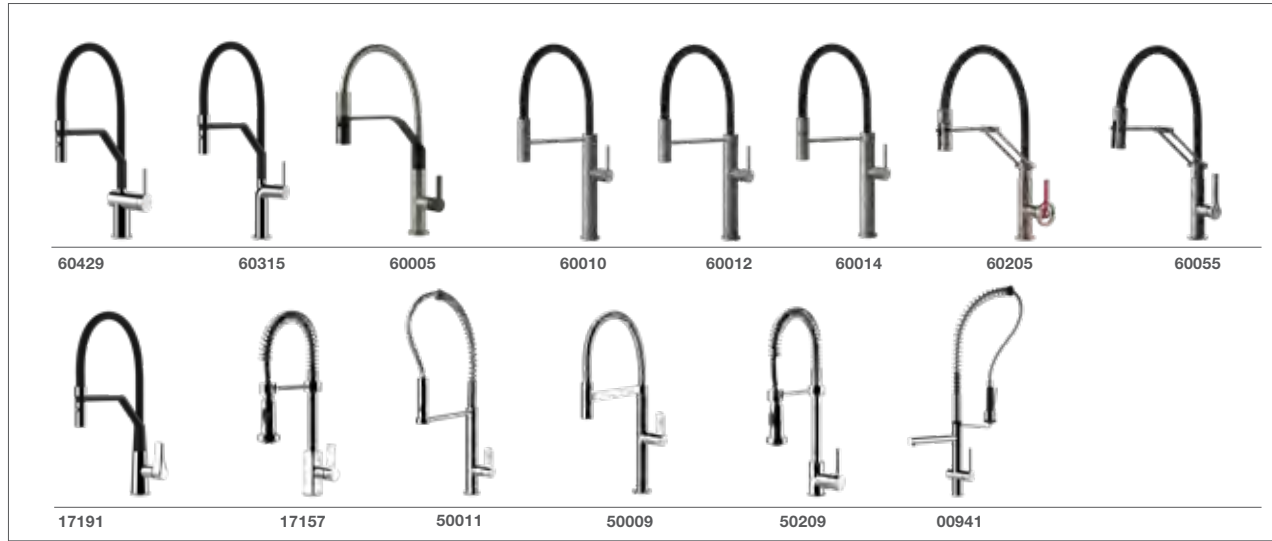

SIDE LEVER TAPS  
J Shape



SIDE LEVER TAPS  
U Shape ergonomic handshower



SIDE LEVER TAPS  
U Shape



SIDE LEVER TAPS  
L shape



SIDE LEVER TAPS  
SLANTED



SIDE LEVER  
OLD STYLE



WINDOW SOLUTIONS

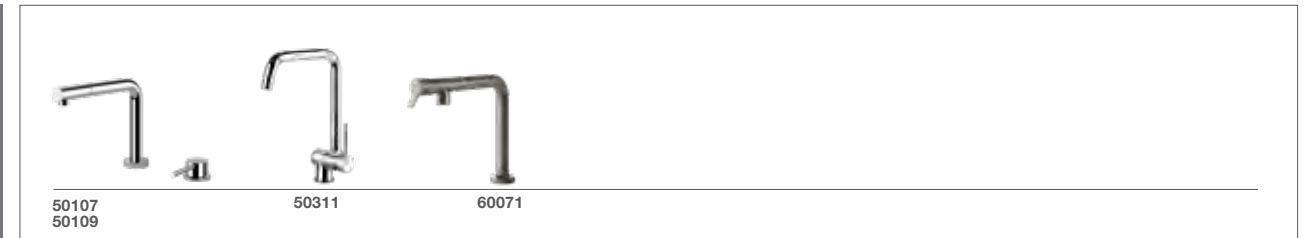

TOP LEVER TAPS  
HIGH SPOUT



TOP LEVER TAPS  
LOW SPOUT



SOAP DISPENSER

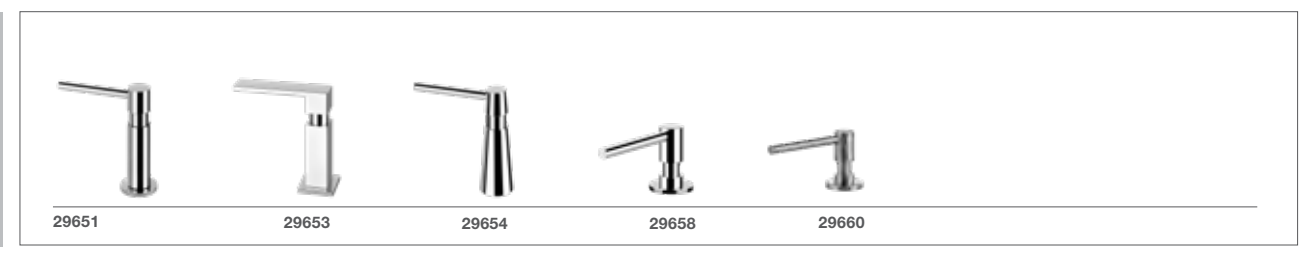



# AT A GLANCE

## EXTRACTIBLE HANDSHOWER

Pull out hand shower provides the greatest freedom of movement. Press the button to switch from the softer aerated flow to the forceful jet spray. The hand shower mixers (single and double jet) are equipped with specially designed components that minimize limestone deposits and also includes a non-return check valve.

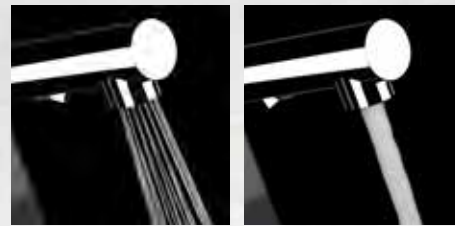

## TYPE OF SPRAY



## GESSI SHINE SURFACE

The special Gessi plating process ensures surfaces are resistant to stains guaranteeing a long lasting and durable sheen to your finish.



## SWIVELLING SPOUT

All kitchen mixers offer the possibility of orientation of the spout, up to a total freedom of movement at 360 °.

## ROTATION ANGLE

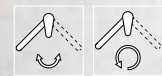

## CARTRIDGES

All mixer contain ceramic disk cartridge and are tested to 70000 opening/closing movements, this correspond to 10 years of use by an average family of 4. In the tests performed by Gessi the cartridges failed after 200000 opening and closing movements using medium/hard water. A sample "hammer test" is performed, which consist of the rapid opening of the mixer which exposes the cartridge to a sudden shock caused by the water pressure. The test is classified as a pass when the cartridge still operates when opened at a water pressure of up to 50 bar.



## Ø CARTRIDGE

## Ø HOLE SIZE

# FINISHINGS



**031**  
Chrome



**149**  
Finox



**239**  
Steel Brushed



**140**  
Bronze

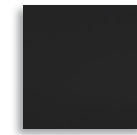

**299**  
Matte Black



**187**  
Aged Bronze



**713**  
Antique brass



**599**  
Matte Black /  
Finox

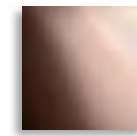

**030**  
Copper

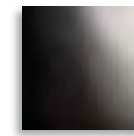

**706**  
Black Metal

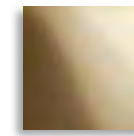

**735**  
Warm bronze

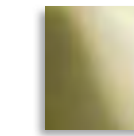

**710**  
Brass



**246**  
Gold PVD



**708**  
Copper Brushed



**707**  
Black Metal  
Brushed

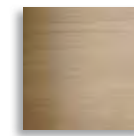

**726**  
Warm Bronze  
Brushed



**727**  
Brass Brushed



**125**  
Copper Brushed  
GHRC



**126**  
Black Metal  
Brushed GHRC







## INDEX

00941	pag	156-157	60016	pag	32-33
08744	pag	168-169	60018	pag	34-35
17015	pag	146-147	60020	pag	36-37
17047	pag	152-153	60022	pag	32-33
17114	pag	188-189	60024	pag	34-35
17116	pag	192-193	60026	pag	36-37
17118	pag	184-185	60051	pag	94-95
17120	pag	180-181	60053	pag	94-95
17151	pag	118-119	60055	pag	92-93
17153	pag	118-119	60071	pag	76-77
17155	pag	182-183	60073	pag	72-73
17157	pag	172-173	60075	pag	142-143
17159	pag	174-175	60077	pag	142-143
17163	pag	174-175	60201	pag	84-85
17169	pag	182-183	60203	pag	84-85
17171	pag	122-123	60205	pag	82-83
17173	pag	192-193	60207	pag	86-87
17175	pag	120-121	60301	pag	46-47
17177	pag	120-121	60303	pag	46-47
17179	pag	122-123	60309	pag	48-49
17191	pag	116-117	60311	pag	48-49
18971	pag	188-189	60313	pag	44-45
20570	pag	180-181	60315	pag	42-43
20577	pag	128-129	60411	pag	58-59
20587	pag	126-127	60413	pag	58-59
29651	pag	196-197	60421	pag	60-61
29653	pag	196-197	60425	pag	56-57
29654	pag	196-197	60429	pag	54-55
29658	pag	196-197	60431	pag	62-63
29660	pag	196-197	60433	pag	62-63
50007	pag	150-151	60435	pag	64-65
50009	pag	140-141	60451	pag	66-67
50011	pag	138-139	60457	pag	66-67
50103	pag	144-145	60471	pag	68-69
50105	pag	144-145	60477	pag	68-69
50107	pag	164-165	60496	pag	134-135
50109	pag	164-165	60498	pag	134-135
50209	pag	178-179	60537	pag	132-133
50301	pag	160-161			
50303	pag	160-161			
50311	pag	158-159			
50407	pag	190-191			
50413	pag	190-191			
58701	pag	108-109			
58703	pag	110-111			
60001	pag	102-103			
60003	pag	104-105			
60005	pag	100-101			
60010	pag	26-27			
60012	pag	28-29			
60014	pag	30-31			

# 316 KITCHEN

## L'ACCIAIO TESSUTO INCONTRA IL COLORE: NUOVI MIX DECORATIVI E TATTILI

La nuova gamma di prodotti semi industriali che si aggiunge alla collezione GESSI 316 KITCHEN esalta ulteriormente i contenuti decorativi dell'"ACCIAIO TESSUTO" ideato da Gessi. Gli eleganti pattern "incisi" sull'acciaio prendono ulteriore corpo e valorizzazione su un prodotto tecnico come il rubinetto semi-industriale, coniugandosi all'impiego di un elegante flessibile in gomma liscio, morbido e colorato che crea un piacevole contrasto e gioco tattile con la tridimensionalità delle incisioni sull'acciaio. Il gioco di contrasti è inoltre amplificato dall'interessante abbinamento di colori tra acciaio e gomma, mutuato dalle ultime tendenze nella moda e nell'interior design.

## WOVEN STEEL MEETS COLOUR: NEW DECORATIVE AND TACTILE MIXES

The new line of semi industrial products, added to GESSI 316 KITCHEN collection, exalts even more the decorative contents of "WOVEN STEEL" created by Gessi. The value of the elegant patterns "engraved" on steel is even increased on a technical product like the semi-industrial tap, which is combined with a colored, elegant, smooth, and rubbery flexible hose that creates a pleasant contrast with the three-dimensionality with the engravings on steel. Moreover, the contrast is amplified by the interesting matching of steel and rubber colors, following the latest trends of fashion and interior design.





# 316 KITCHEN

## ACCIAIO, UN MATERIALE STRAORDINARIO PER UNO STRAORDINARIO DESIGN

Un materiale nobile e prezioso, duraturo nel tempo, resistente e che fosse anche bello da vedere. Un elemento che esaltasse, con semplicità, la rubinetteria Gessi attraverso un design cilindrico, di grande immediatezza visiva e raffinatezza essenziale: nasce il Sistema Gessi 316, protagonista, l'esclusivo acciaio inossidabile AISI 316.

## STEEL, AN EXTRAORDINARY MATERIAL FOR AN EXTRAORDINARY DESIGN

A noble and precious material, long lasting, resistant and aesthetically pleasing. This element exalts Gessi faucets with simplicity, with an eye-catching cylindrical design of essential sophistication.



727

BRASS  
BRUSHED

726

WARM  
STEEL B.

708

COPPER B.

707

BLACK  
METAL B.

239

STEEL B.

299

MATTE  
BLACK





# 316 KITCHEN

## RILIEVI DI CHARME

I pattern affascinanti, attraverso l'esclusiva lavorazione dell'acciaio inossidabile, creano pezzi dal sapore speciale, perfetti per chi ama l'essenzialità, ma vuole dare alla cucina un tocco raffinato, high-tech ma caldo e decorativo.

## CHARMING PATTERNS

The charming patterns, through the exclusive manufacturing of the stainless steel, create pieces of special taste, perfect for who loves the essentiality, but wants to give to the kitchen a refinement touch, high-tech but decorative but warm.

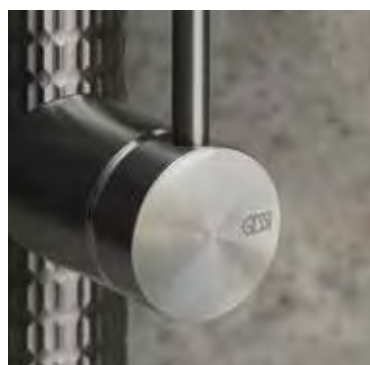

FLESSA CESELLO MECCANICA



# 316 KITCHEN



BLACK METAL BRUSHED

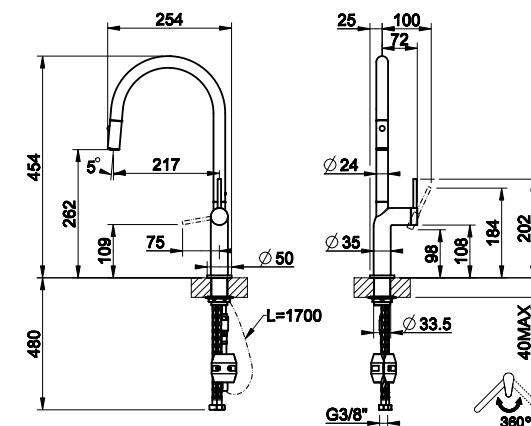

## 60010

Miscelatore semi pro monocomando  
Semi-professional sink mixer  
Mitigeur semi-professionnelle  
Semi-Pro Einhebelmischer

- 1
- Ø33,5 mm
- 360°
- Ø25mm



#707 BLACK METAL BRUSHED   #239 STEEL BRUSHED   #299 MATTE BLACK   #727 BRASS BRUSHED   #708 COPPER BRUSHED   #726 WARM BRONZE BRUSHED

60010 239	Steel Brushed	705
60010 707	Black Metal Brushed	1.045
60010 708	Copper Brushed	1.045
60010 726	Warm Bronze Brushed	1.045
60010 727	Brass Brushed	1.045
60010 299	Matte Black	970



# 316 KITCHEN MECCANICA

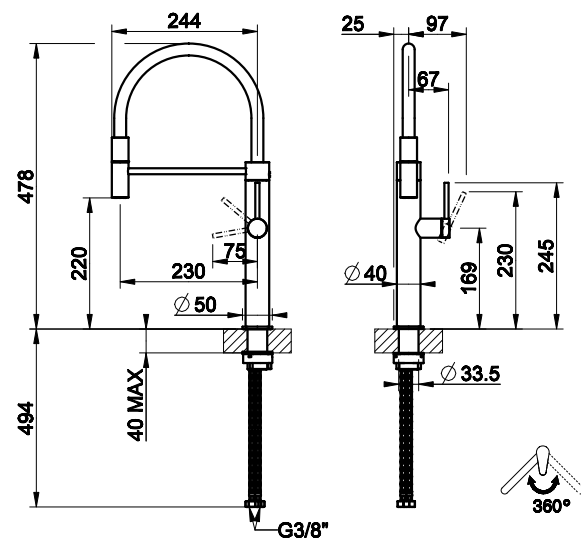

## 60012

Miscelatore semi pro monocomando  
 Semi-professional sink mixer  
 Mitigeur semi-professionnelle  
 Semi-Pro Einhebelmischer

- 1
- Ø33,5 mm
- 360°
- Ø25mm

60012	239	Steel Brushed	840
60012	707	Black Metal Brushed	1.245
60012	708	Copper Brushed	1.245
60012	726	Warm Bronze Brushed	1.245
60012	727	Brass Brushed	1.245
60012	299	Matte Black	1.150



BLACK METAL BRUSHED



# 316 KITCHEN

## CESELLO



COPPER BRUSHED

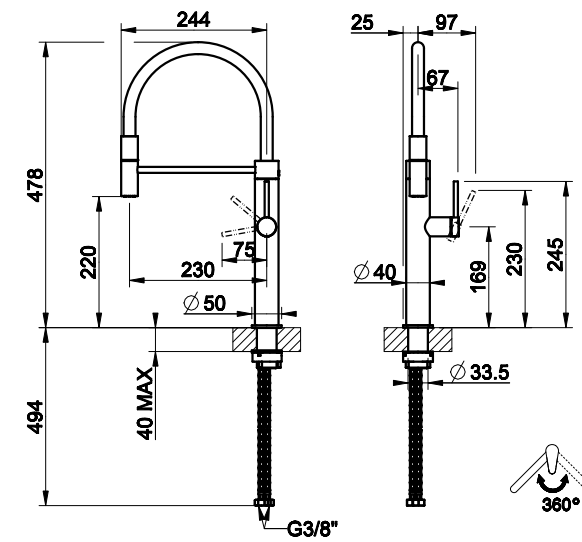

### 60014

Miscelatore semi pro monocomando  
 Semi-professional sink mixer  
 Mitigeur semi-professionnelle  
 Semi-Pro Einhebelmischer

- 1
- Ø33,5 mm
- 360°
- Ø25mm

60014 239	Steel Brushed	840
60014 707	Black Metal Brushed	1.245
60014 708	Copper Brushed	1.245
60014 726	Warm Bronze Brushed	1.245
60014 727	Brass Brushed	1.245
60014 299	Matte Black	1.150



#708 COPPER BRUSHED    #239 STEEL BRUSHED    #299 MATTE BLACK    #727 BRASS BRUSHED    #707 BLACK METAL BRUSHED    #726 WARM BRONZE BRUSHED

GESSI 316





316 KITCHEN

WARM BRONZE BRUSHED

DESIGN\_GESSI STYLE STUDIO  
GESSI PATENT



#726 WARM BRONZE BRUSHED

#239 STEEL BRUSHED

#299 MATTE BLACK

#727 BRASS BRUSHED

#707 BLACK METAL BRUSHED

#708 COPPER BRUSHED

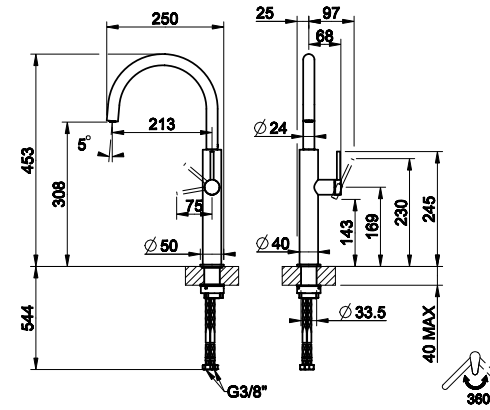

### 60016

Miscelatore monocomando  
Sink mixer  
Mitigeur  
Einhebelmischer

Ø33,5 mm

360°

Ø25mm

60016 239	Steel Brushed	610
60016 707	Black Metal Brushed	955
60016 708	Copper Brushed	955
60016 726	Warm Bronze Brushed	955
60016 727	Brass Brushed	955
60016 299	Matte Black	920

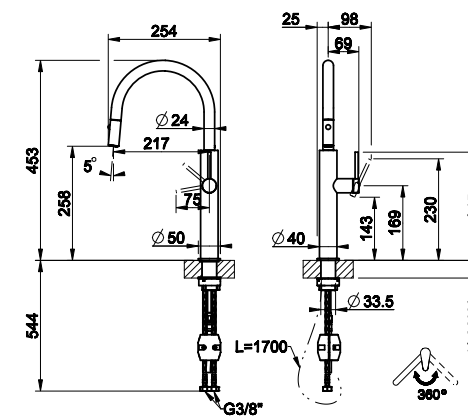

### 60022

Miscelatore monocomando  
Sink mixer  
Mitigeur  
Einhebelmischer

2

Ø33,5 mm

360°

Ø25mm

60022 239	Steel Brushed	685
60022 707	Black Metal Brushed	1.015
60022 708	Copper Brushed	1.015
60022 726	Warm Bronze Brushed	1.015
60022 727	Brass Brushed	1.015
60022 299	Matte Black	970

GESSI316





316 KITCHEN MECCANICA

MATTE BALCK  
DESIGN\_GESSI STYLE STUDIO  
©GESSI PATENT



#299 MATTE BLACK    #239 STEEL BRUSHED    #727 BRASS BRUSHED    #708 COPPER BRUSHED    #707 BLACK METAL BRUSHED    #726 WARM BRONZE BRUSHED

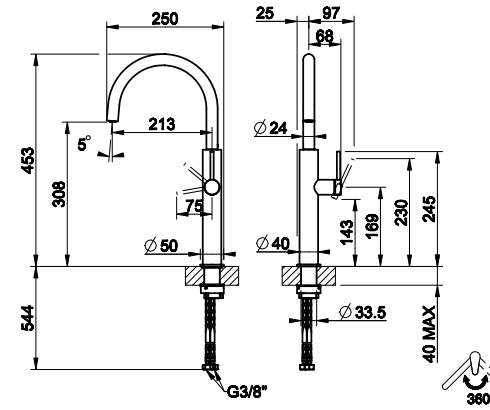

### 60018

Miscelatore monocomando  
Sink mixer  
Mitigeur  
Einhebelmischer



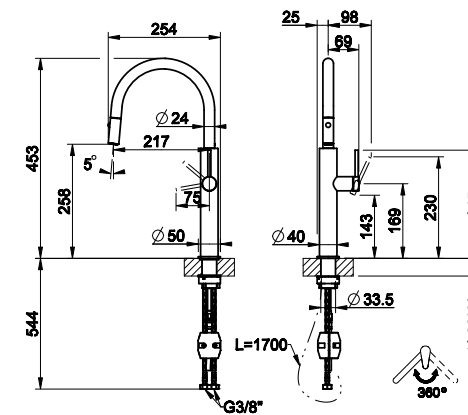

-  Ø33,5 mm
-  360°
-  Ø25mm

60018	239	Steel Brushed	750
60018	707	Black Metal Brushed	1.155
60018	708	Copper Brushed	1.155
60018	726	Warm Bronze Brushed	1.155
60018	727	Brass Brushed	1.155
60018	299	Matte Black	1.080



### 60024

Miscelatore monocomando  
Sink mixer  
Mitigeur  
Einhebelmischer

-  2
-  Ø33,5 mm
-  360°
-  Ø25mm

60024	239	Steel Brushed	810
60024	707	Black Metal Brushed	1.215
60024	708	Copper Brushed	1.215
60024	726	Warm Bronze Brushed	1.215
60024	727	Brass Brushed	1.215
60024	299	Matte Black	1.140

GESSI316







316 KITCHEN  
CESELLO

BLACK METAL BRUSHED

DESIGN\_GESSI STYLE STUDIO  
GESSI PATENT



#707 BLACK METAL BRUSHED

#239 STEEL BRUSHED

#299 MATTE BLACK

#727 BRASS BRUSHED

#708 COPPER BRUSHED

#726 WARM BRONZE BRUSHED

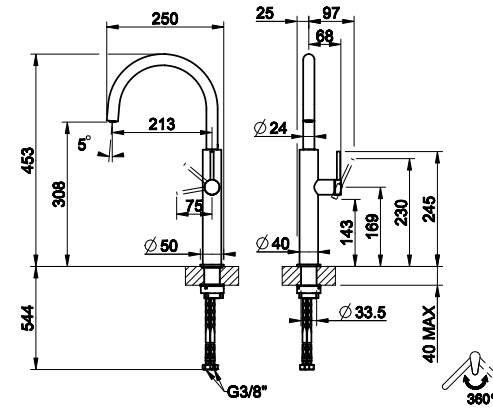

## 60020

Miscelatore monocomando  
Sink mixer  
Mitigeur  
Einhebelmischer

Ø33,5 mm

360°

Ø25mm

60020	239	Steel Brushed	750
60020	707	Black Metal Brushed	1.155
60020	708	Copper Brushed	1.155
60020	726	Warm Bronze Brushed	1.155
60020	727	Brass Brushed	1.155
60020	299	Matte Black	1.080

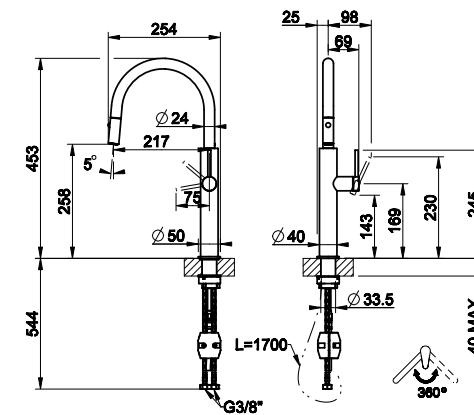

## 60026

Miscelatore monocomando  
Sink mixer  
Mitigeur  
Einhebelmischer

2

Ø33,5 mm

360°

Ø25mm

60026	239	Steel Brushed	810
60026	707	Black Metal Brushed	1.215
60026	708	Copper Brushed	1.215
60026	726	Warm Bronze Brushed	1.215
60026	727	Brass Brushed	1.215
60026	299	Matte Black	1.140

GESSI316



Gessi experiments with new aesthetic and functional languages, drawing on the organic style of natural elements. Thanks to these references, the kitchen finds a renewed sense of well-being and balance, as only nature can give. An inedited design, inspired by the sinuous forms of nature, where aesthetics and functionality merge and elevate each other. Pleasant to the senses, the soft and familiar contours of Stelo make one's living space personal and welcoming, modern but relaxing. With its organic lines Stelo gives the room a comfort and well-being that only natural elements can give.

# STELO

**Design armonizzato e forme naturali**

ORGANIC DESIGN AND NATURAL SHAPE

Gessi sperimenta nuovi linguaggi estetici e funzionali, attingendo dagli stilemi organici degli elementi naturali. Grazie a questi riferimenti, la cucina trova un rinnovato senso di benessere ed equilibrio, come solo la natura sa donare. Un design inedito, ispirato alle forme sinuose della natura, dove estetica e funzionalità si fondono ed esaltano reciprocamente. Piacevoli ai sensi, le linee morbide e familiari di Stelo rendono lo spazio abitativo personale ed accogliente, moderno ma rilassante. Con le sue linee organiche Stelo dona all'ambiente un comfort e un benessere che solo elementi naturali sanno conferire. Segno distintivo della collezione l'originale piegatura del corpo in un pezzo unico che si raccorda con la maniglia. Disponibile nelle versioni con canna a L, J, U e semindustriale, Stelo presenta inoltre l'innovativa doccetta con comando in testa.



- CHROME 031
- FINOX 149
- MATTE BLACK 299
- GHRC BLACK METAL B. 126
- GHRC COPPER B. 125

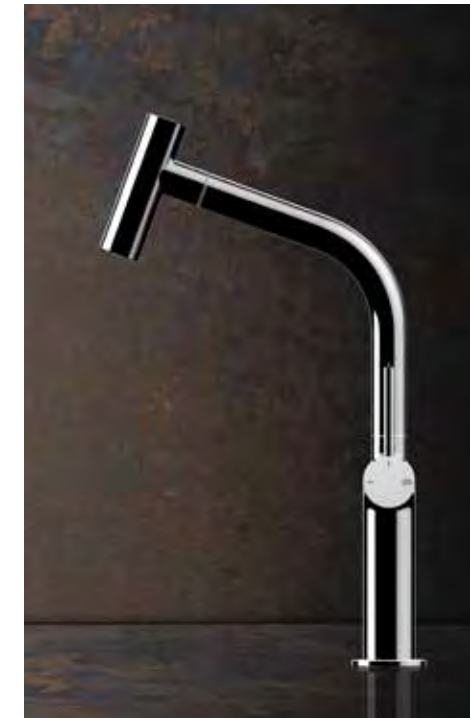

## STELO collection



The distinctive sign of the collection is the original folding of the body in a single piece that connects with the handle. Available in L, J, U and semi-industrial versions, Stelo also features the innovative overhead control double jet spray.

DESIGN\_GESSI STYLE STUDIO  
GESSI PATENT







- 031  
FINOX CHROME
- 149  
FINOX
- 299  
MATTE BLACK
- 126  
GHRC BLACK METAL B.
- 125  
GHRC COPPER B.

# STELO

collection

## INNOVAZIONE E STILE PER VIVERE LA CUCINA

Con un taglio deciso ma dalle forme morbide e slanciate, Gessi crea un nuovo idioma estetico in cucina, coniugando creatività e raffinatezza in un'ammiccante gioco di sinuosità.

## INNOVATION AND STYLE TO LIVE THE KITCHEN

With a decisive cut but with soft and slender shapes, Gessi creates a new aesthetic code in the kitchen, combining creativity and refinement in a seductive game of sinuosity.







# STELO

COLLECTION

MATTE BLACK

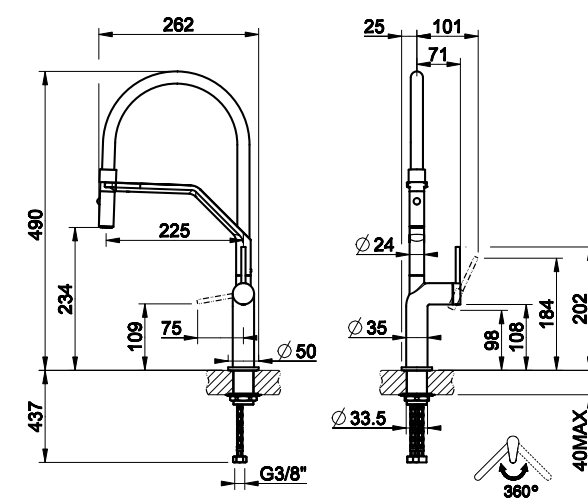

## 60315

Miscelatore semi pro monocomando  
 Semi- professional sink mixer  
 Mitigeur semi-professionelle  
 Semi-Pro Einhebelmischer

- 2
- Ø33,5 mm
- 360°
- Ø25mm

60315	031	Chrome	430
60315	149	Finox	495
60315	299	Matte Black	485



#299 MATTE BLACK

#149 FINOX

#031 CHROME



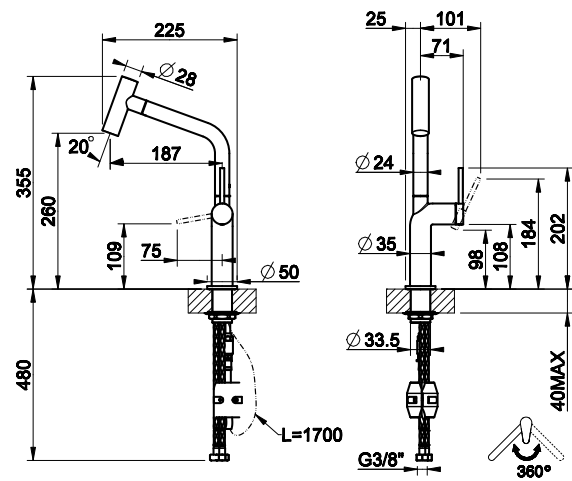

### 60313

Miscelatore monocomando  
Sink mixer  
Mitigeur  
Einhebelmischer

- 2
- Ø33,5 mm
- 360°
- Ø25mm

60315 031 Chrome

400



# STELO COLLECTION



**MATTE BLACK**  
DESIGN\_GESSI STYLE STUDIO  
GESSI PATENT



#299 MATTE BLACK

#031 CHROME

#149 FINOX

#126 BLACK METAL BRUSHED

#125 COPPER BRUSHED

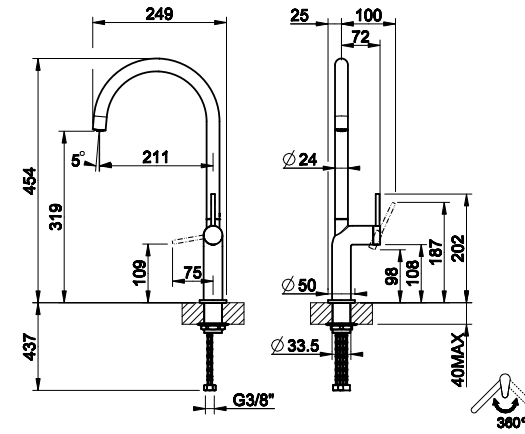

## 60301

Miscelatore monocomando  
Sink mixer  
Mitigeur  
Einhebelmischer

Ø33,5 mm

360°

Ø25mm

60301	031	Chrome	285
60301	149	Finox	355
60301	299	Matte Black	345
60301	125	Copper Brushed GHRC	400
60301	126	Black Metal Brushed GHRC	400

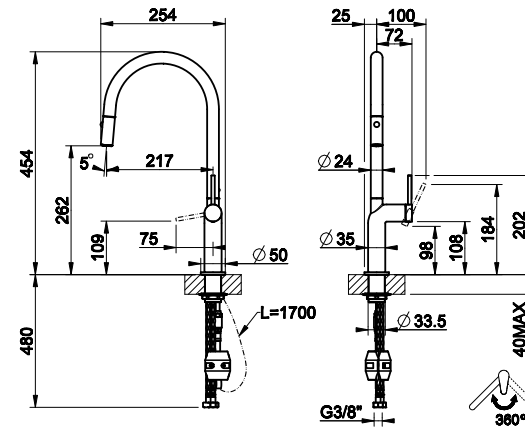

## 60303

Miscelatore monocomando  
Sink mixer  
Mitigeur  
Einhebelmischer

2

Ø33,5 mm

360°

Ø25mm

60303	031	Chrome	355
60303	149	Finox	430
60303	299	Matte Black	420
60303	125	Copper Brushed GHRC	450
60303	126	Black Metal Brushed GHRC	450

STELO







STELO  
COLLECTION

FINOX  
DESIGN\_GESSI STYLE STUDIO  
GESSI PATENT



#149 FINOX #031 CHROME #299 MATTE BLACK #126 BLACK METAL BRUSHED #125 COPPER BRUSHED

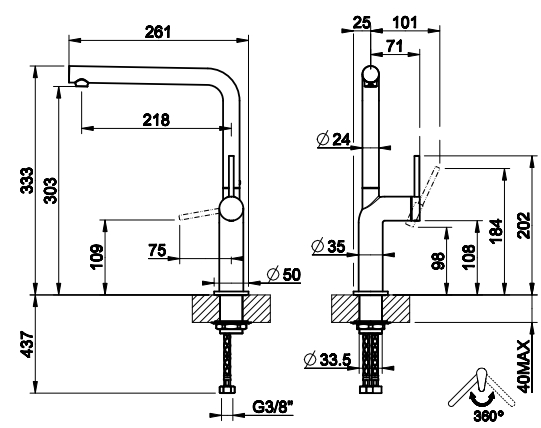

**60309**

Miscelatore monocomando  
Sink mixer  
Mitigeur  
Einhebelmischer

- Ø33,5 mm
- 360°
- Ø25mm

60309	031	Chrome	285
60309	149	Finox	355
60309	299	Matte Black	345
60309	125	Copper Brushed GHRC	380
60309	126	Black Metal Brushed GHRC	380

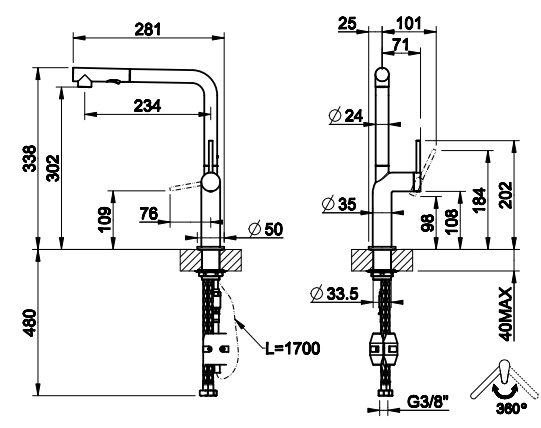

**60311**

Miscelatore monocomando  
Sink mixer  
Mitigeur  
Einhebelmischer

- 2
- Ø33,5 mm
- 360°
- Ø25mm

60311	031	Chrome	355
60311	149	Finox	430
60311	299	Matte Black	420
60311	125	Copper Brushed GHRC	475
60311	126	Black Metal Brushed GHRC	475

STELO



# INEDITO

**Inedito reinventa il design minimale ispirandosi alla forme geometriche pure**

INEDITO REINVENTS MINIMAL DESIGN DRAWING  
INSPIRATION FROM GEOMETRICAL PURE SHAPES

La ricerca della perfezione nei propri spazi privati dell'abitare, oggi porta a individuare dettagli sempre più ricercati e all'insegna della purezza formale. Gessi interpreta questa tendenza con caratterizzazioni estetiche alla ricerca della personalizzazione per l'utilizzatore, con maniglie senza tagli e con lavorazioni meccaniche ispirate da segni tecnici. Le customizzazioni con estetiche "godronato" e "ingranaggio" rendono peculiare il prodotto e caratterizzante nell'ambiente. Il rubinetto, quale oggetto che occupa un posto di primo piano nella cucina, visivamente centrale e utilizzato frequentemente, è un elemento che dà carattere ed esso diviene veramente un oggetto che esprime personalità e stile.



The search for perfection in their own private living spaces, today leads to identifying ever more refined details in the name of formal purity. Gessi interprets this trend with aesthetic characterizations in search of customization for the user, with handles without cuts and with mechanical processing inspired by technical signs. Customizations with "godronato" and "ingranaggio" aesthetics make the product unique and characterizing in the environment. The faucet, as an object that occupies a prominent place in the kitchen, visually central and frequently used, is an element that gives character and it truly becomes an object that expresses personality and style.



DESIGN\_GESSI STYLE STUDIO  
GESSI PATENT



INEDITO  
collection





MATTE BLACK 299

GHFC BLACK METAL B. 126

GHFC COPPER B. 125



Grazie a finiture speciali, la collezione si integra perfettamente in tutti gli ambienti cucina, oltre ad assecondare tutte le esigenze "pratiche" con la possibilità di spaziare all'interno della gamma tra versioni girevoli ed estraibili, oltre che a perfezionarsi in canne a J, T, U ed L e semi pro.

La cucina diventa quindi centrale nel progetto dell'abitare e riscopre il suo ruolo di cuore della casa.

Thanks to special finishes, the collection is perfectly integrated in all the kitchen environments, as well as satisfying all the "practical" needs with the possibility of moving within the range of swivelling and pull-out versions, as well as perfecting them in J, T, U and L spouts and semi pro. The kitchen thus becomes central to the project of living and rediscovers its role as the heart of the home.

ART FOR CHEFS

149 FINOX

031 CHROME

**UNPRECEDENTED STYLE COMBINATIONS OF PURE SHAPES BEYOND FASHION**

Gessi's INEDITO Collection infuses the kitchen with a new and unique purity of design, giving proportions that convey solidity and at the same time clean shapes and style.

Inedito, minimal and cutting-edge in style concepts thanks to the cylindrical shapes that intersect each other, rediscovers with innovative features the circular shapes that are beyond any fashion concept and that can adapt to all styles of the kitchen.



DESIGN\_GESSI STYLE STUDIO  
GESSI PATENT

# INEDITO collection

**INEDITE COMBINAZIONI DI FORME PURE OLTRE OGNI CONCETTO DI MODA**

La Collezione INEDITO di Gessi infonde all'ambiente cucina una nuova e unica purezza del design, regalando proporzioni che trasmettono solidità e allo stesso tempo pulizia nelle forme e nello stile. Minimale e all'avanguardia nei concetti di stile grazie alle forme cilindriche che si intersecano tra loro, Inedito riscopre con innovative caratteristiche le forme circolari che si posizionano oltre ogni concetto di moda e che si adattano a tutti gli stili di ambiente.





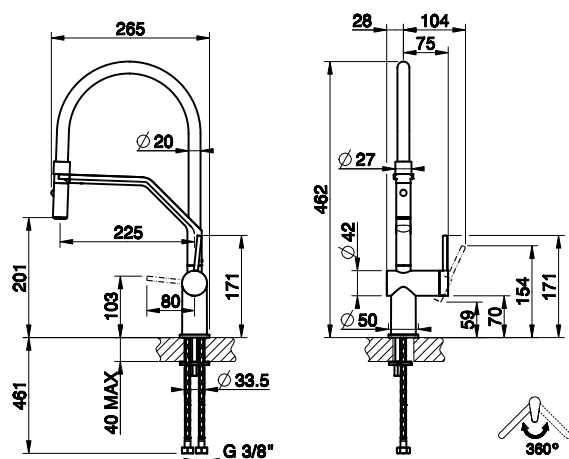

# INEDITO COLLECTION



## 60429

Miscelatore semi pro monocomando  
Semi-professional sink mixer  
Mitigeur semi-professionnelle  
Semi-Pro Einhebelmischer

-  2
-  Ø33,5 mm
-  360°
-  Ø35mm

60429	031	Chrome	400
60429	149	Finox	490
60429	299	Matte Black	460
60429	125	Copper Brushed GHRC	500
60429	126	Black Metal Brushed GHRC	500



MATTE BLACK



#299 MATTE BLACK

#031 CHROME

#149 FINOX

#125 COPPER BRUSHED

#126 BLACK METAL BRUSHED





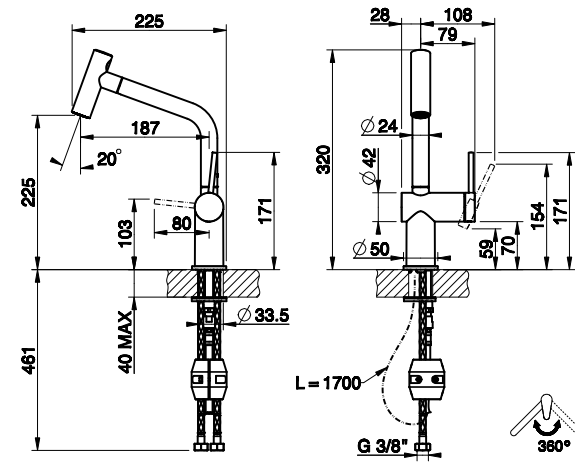

# INEDITO COLLECTION



## 60425

Miscelatore monocomando  
Sink mixer  
Mitigeur  
Einhebelmischer

-  2
-  Ø33,5 mm
-  360°
-  Ø35mm

60425	031	Chrome	355
60425	149	Finox	460
60425	299	Matte Black	430
60425	125	Copper Brushed GHRC	490
60425	126	Black Metal Brushed GHRC	490



#031 CHROME

#149 FINOX

#299 MATTE BLACK

#125 COPPER BRUSHED

#126 BLACK METAL BRUSHED

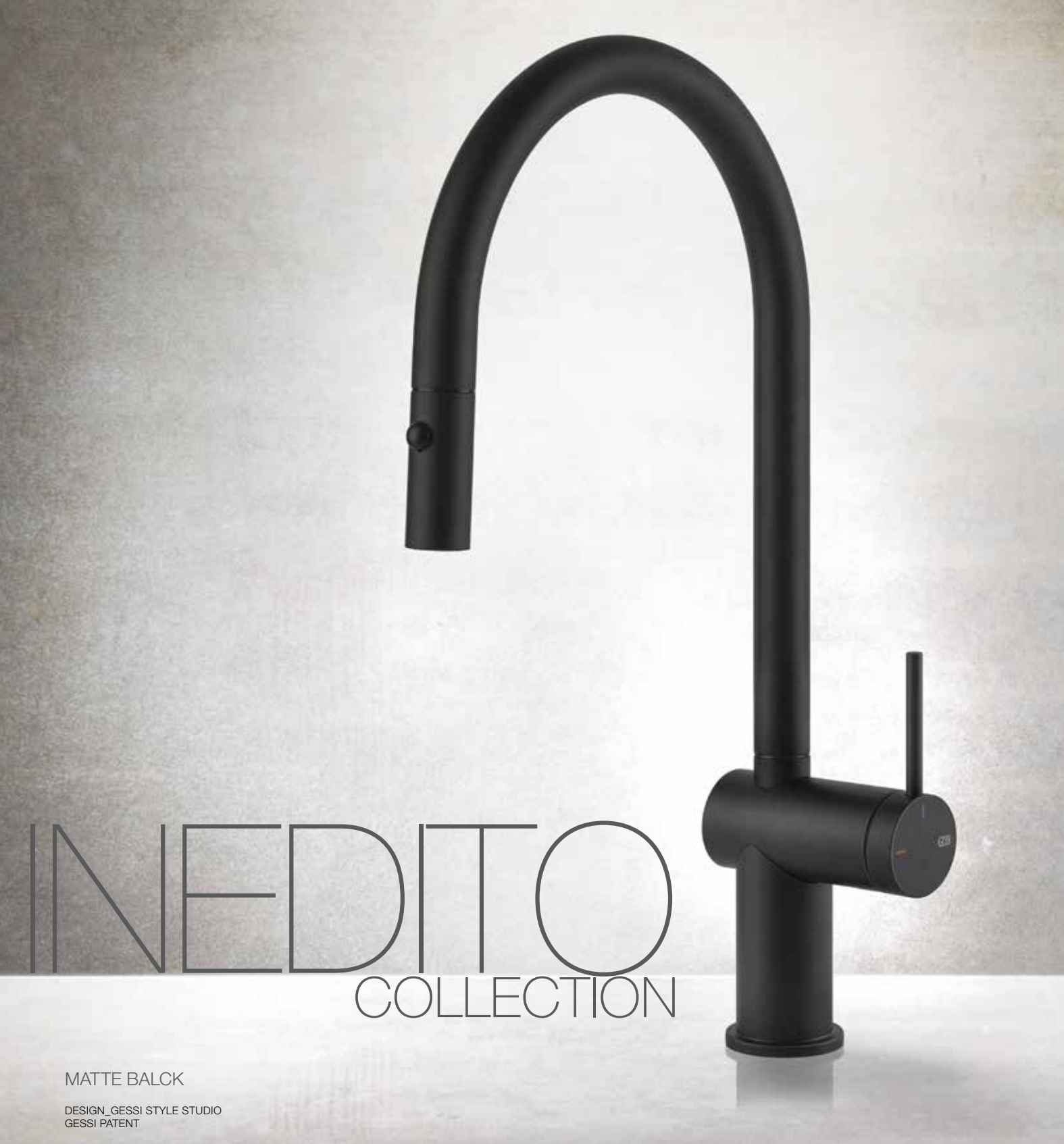

MATTE BALCK

DESIGN\_GESSI STYLE STUDIO  
GESSI PATENT

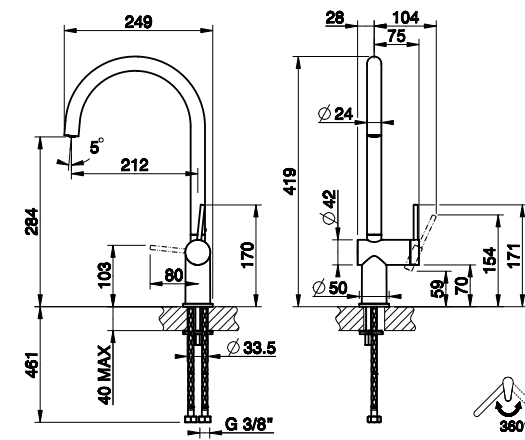

### 60411

Miscelatore monocomando  
Sink mixer  
Mitigeur  
Einhebelmischer

Ø33,5 mm

360°

Ø35mm

60411 031	Chrome	220
60411 149	Finox	295
60411 299	Matte Black	290
60411 125	Copper Brushed GHRC	355
60411 126	Black Metal Brushed GHRC	355

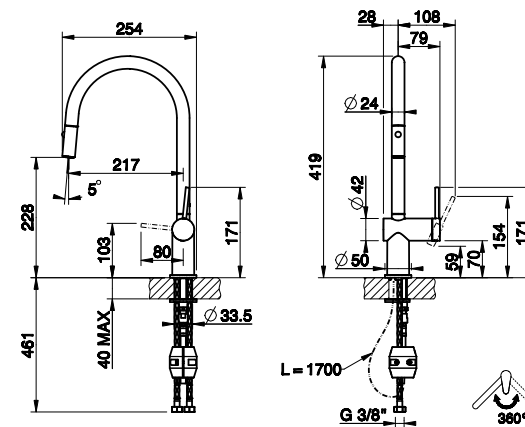

### 60413

Miscelatore monocomando  
Sink mixer  
Mitigeur  
Einhebelmischer

2

Ø33,5 mm

360°

Ø35mm

60413 031	Chrome	300
60413 149	Finox	375
60413 299	Matte Black	370
60413 125	Copper Brushed GHRC	430
60413 126	Black Metal Brushed GHRC	430

INEDITO



#299 MATTE BLACK

#031 CHROME

#149 FINOX

#126 BLACK METAL BRUSHED

#125 COPPER BRUSHED







CHROME

DESIGN\_GESSI STYLE STUDIO  
GESSI PATENT

# INEDITO

## COLLECTION

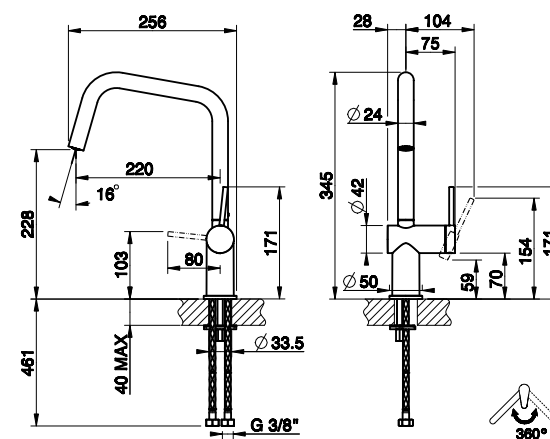

**60421**

Miscelatore monocomando  
Sink mixer  
Mitigeur  
Einhebelmischer

Ø33,5 mm

360°

Ø35mm

<b>60421</b>	<b>031</b>	Chrome	<b>205</b>
<b>60421</b>	<b>149</b>	Finox	<b>275</b>
<b>60421</b>	<b>299</b>	Matte Black	<b>265</b>
<b>60421</b>	<b>125</b>	Copper Brushed GHRC	<b>315</b>
<b>60421</b>	<b>126</b>	Black Metal Brushed GHRC	<b>315</b>



#031 CHROME

#149 FINOX

#299 MATTE BLACK

#126 BLACK METAL  
BRUSHED

#125 COPPER  
BRUSHED

INEDITO



INEDITO  
COLLECTION

CHROME  
DESIGN\_GESSI STYLE STUDIO  
GESSI PATENT



#031 CHROME    #149 FINOX    #299 MATTE BLACK    #126 BLACK METAL BRUSHED    #125 COPPER BRUSHED

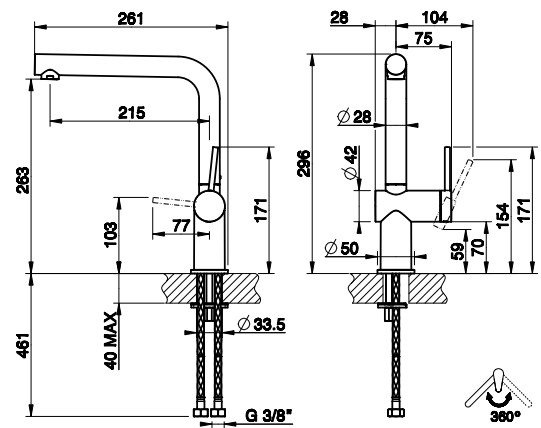

**60431**

Miscelatore monocomando  
Sink mixer  
Mitigeur  
Einhebelmischer

- Ø33,5 mm
- 360°
- Ø35mm

60431	031	Chrome	215
60431	149	Finox	295
60431	299	Matte Black	285
60431	125	Copper Brushed GHRC	355
60431	126	Black Metal Brushed GHRC	355

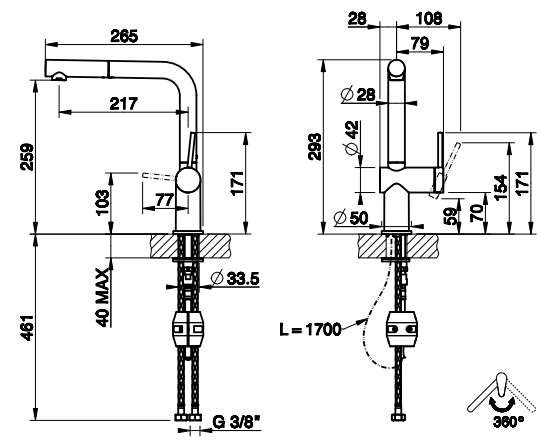

**60433**

Miscelatore monocomando  
Sink mixer  
Mitigeur  
Einhebelmischer

- 1
- Ø33,5 mm
- 360°
- Ø35mm

60433	031	Chrome	265
60433	149	Finox	345
60433	299	Matte Black	335
60433	125	Copper Brushed GHRC	410
60433	126	Black Metal Brushed GHRC	410







CHROME  
DESIGN\_GESSI STYLE STUDIO  
GESSI PATENT

# INEDITO

## COLLECTION

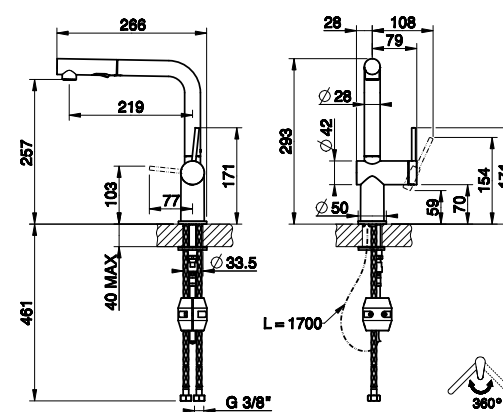

### 60435

Miscelatore monocomando  
Sink mixer  
Mitigeur  
Einhebelmischer

- 2
- Ø33,5 mm
- 360°
- Ø35mm

60435 031	Chrome	300
60435 149	Finox	375
60435 299	Matte Black	370
60435 125	Copper Brushed GHRC	430
60435 126	Black Metal Brushed GHRC	430



#031 CHROME

#149 FINOX

#299 MATTE BLACK

#126 BLACK METAL BRUSHED

#125 COPPER BRUSHED

INEDITO



INEDITO  
COLLECTION

COPPER BRUSHED  
DESIGN\_GESSI STYLE STUDIO  
GESSI PATENT



#125 COPPER BRUSHED    #031 CHROME    #149 FINOX    #299 MATTE BLACK    #126 BLACK METAL BRUSHED

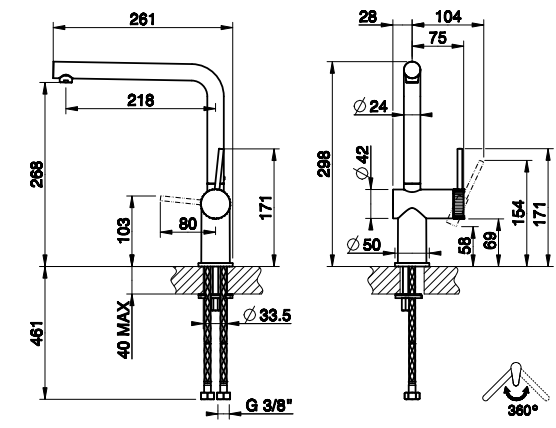

**60451**

Miscelatore monocomando  
Sink mixer  
Mitigeur  
Einhebelmischer

- Ø33,5 mm
- 360°
- Ø35mm

60451 031	Chrome	250
60451 149	Finox	325
60451 299	Matte Black	320
60451 125	Copper Brushed GHRC	390
60451 126	Black Metal Brushed GHRC	390

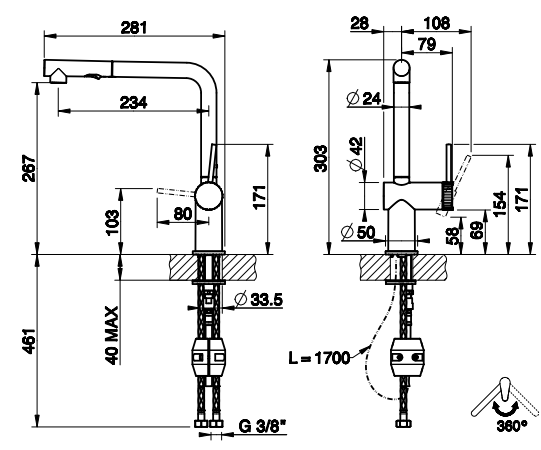

**60457**

Miscelatore monocomando  
Sink mixer  
Mitigeur  
Einhebelmischer

- 2
- Ø33,5 mm
- 360°
- Ø35mm

60457 031	Chrome	330
60457 149	Finox	410
60457 299	Matte Black	405
60457 125	Copper Brushed GHRC	460
60457 126	Black Metal Brushed GHRC	460







INEDITO  
COLLECTION

BLACK METAL BRUSHED

DESIGN\_GESSI STYLE STUDIO  
GESSI PATENT



#126 BLACK METAL BRUSHED    #031 CHROME    #149 FINOX    #299 MATTE BLACK    #125 COPPER BRUSHED

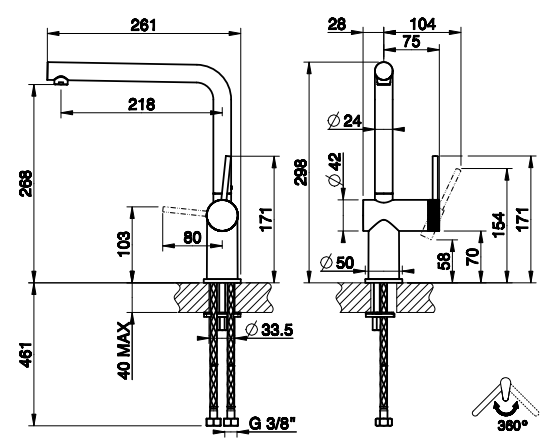

**60471**

Miscelatore monocomando  
Sink mixer  
Mitigeur  
Einhebelmischer

- Ø33,5 mm
- 360°
- Ø35mm

60471 031	Chrome	260
60471 149	Finox	335
60471 299	Matte Black	330
60471 125	Copper Brushed GHRC	400
60471 126	Black Metal Brushed GHRC	400

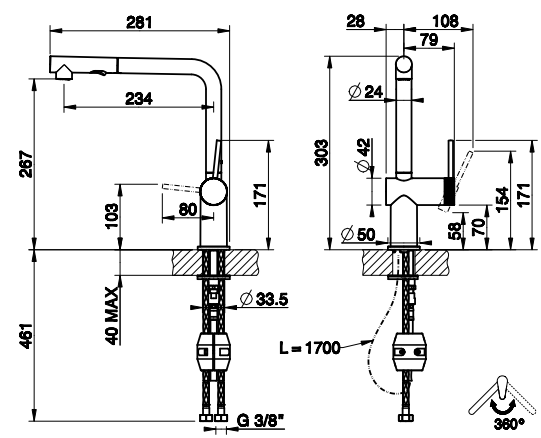

**60477**

Miscelatore monocomando  
Sink mixer  
Mitigeur  
Einhebelmischer

- 2
- Ø33,5 mm
- 360°
- Ø35mm

60477 031	Chrome	340
60477 149	Finox	420
60477 299	Matte Black	415
60471 125	Copper Brushed GHRC	470
60471 126	Black Metal Brushed GHRC	470



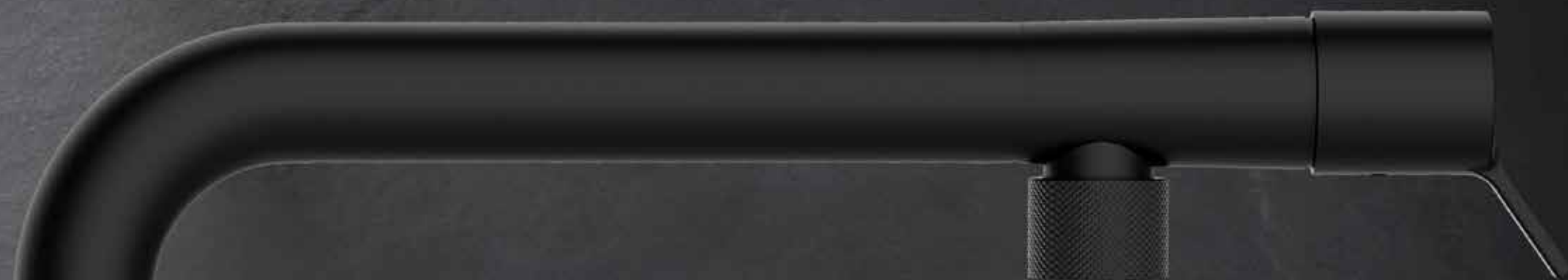

# FISSO

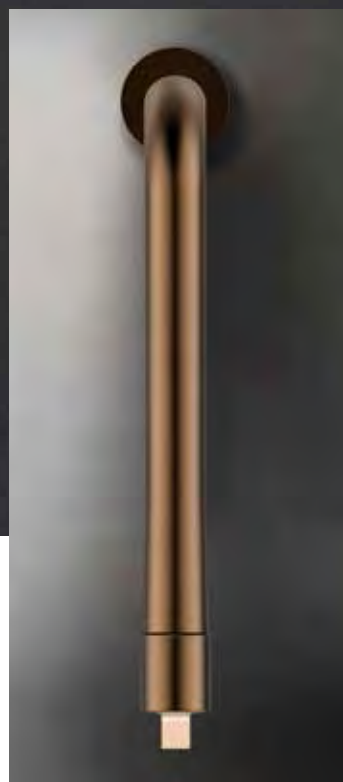

DESIGN\_GESSI STYLE STUDIO  
GESSI PATENT

CHROME 031

FINOX 149

MATTE BLACK 299

WARM STEEL B. 726



# ASSO COLLECTION

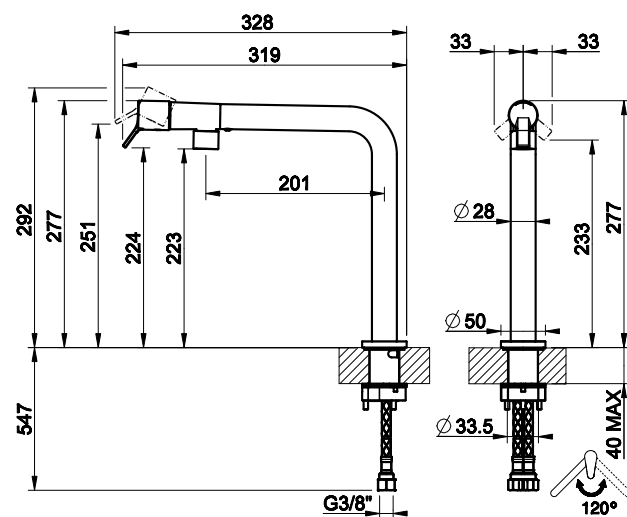

**60073**

Miscelatore monocomando  
Sink mixer  
Mitigeur  
Einhebelmischer

- Ø33,5 mm
- 120°
- Ø25mm

<b>60073 031</b>	Chrome	<b>330</b>
<b>60073 149</b>	Finox	<b>480</b>
<b>60073 299</b>	Matte Black	<b>450</b>
<b>60073 726</b>	Warm Bronze Brushed	<b>580</b>



WARM BRONZE BRUSHED

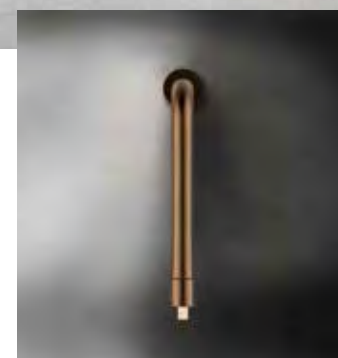

#726 WARM BRONZE BRUSHED



#031 CHROME



#149 FINOX



#299 MATTE BLACK

# SU & GIÙ

**Una soluzione pratica e di stile per la cucina moderna**

A STYLISH AND PRACTICAL SOLUTION FOR MODERN KITCHENS

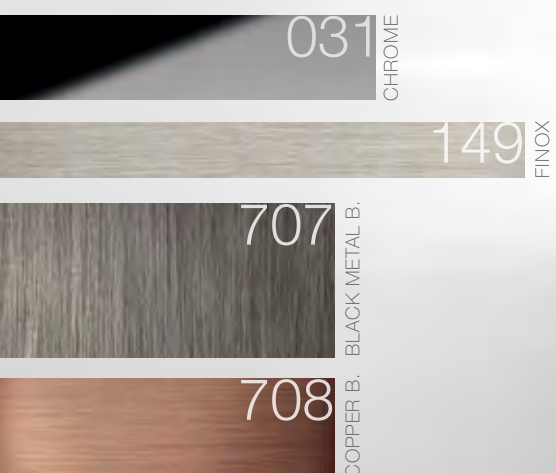

Gessi ha da tempo raccolto questa sfida, fornendo design glamour e brillanti soluzioni tecnologiche per rispondere a una richiesta di zone lavabo con personalità, estetica e funzioni avanzate. Poiché gli spazi abitativi diventano sempre più fluidi e aperti, molto spesso la cucina si apre al soggiorno, o il piano cucina ha poco spazio dedicato, a volte sotto una finestra. Ciò richiede una capacità del rubinetto di "scompare" discretamente contro il lavabo quando esso non sia in uso. Per questo Gessi ha sviluppato una serie di miscelatori abbattibili che possono essere estratti a piena altezza quando necessario e nondimeno azionati in qualsiasi posizione intermedia.

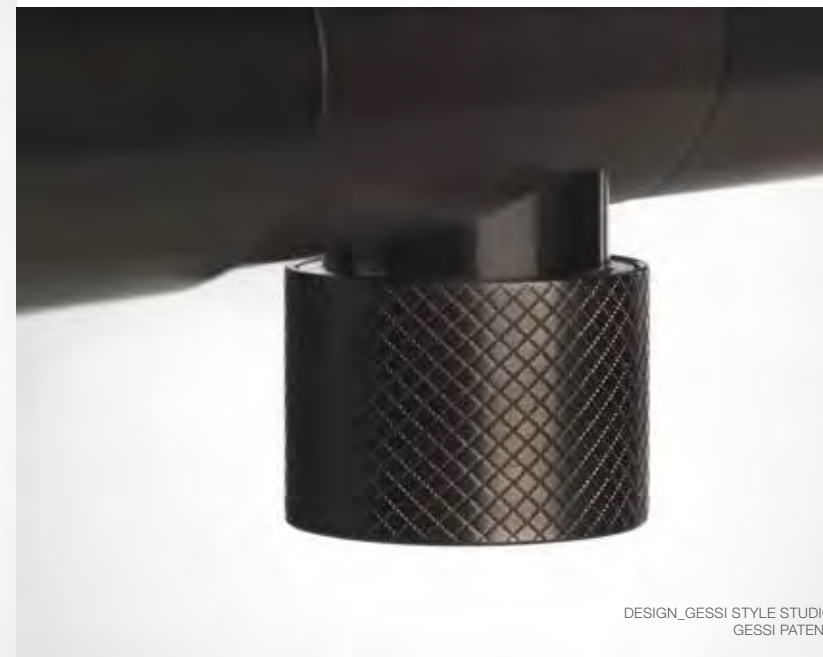

Gessi took up this challenge long ago, replying with glamorous designs and brilliant technological solutions to the request of sink areas with their own personality, aesthetics and advanced functions. Since living spaces become more and more open and fluid, the kitchen area is often open to the living room and the counter often occupies just a small space under a window. This requires a tap able to "disappear" against the sink when it is not being used. Hence, Gessi developed a series of retractable mixers that can be pulled out when it is necessary and at the same time used in every intermediate positioning.





# SU &

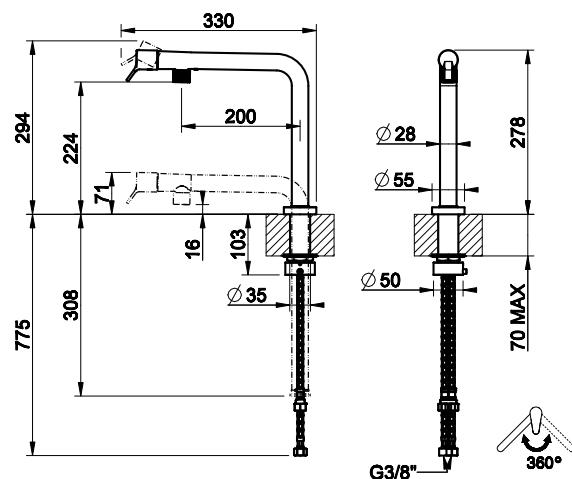

## 60071

Miscelatore monocomando  
Sink mixer  
Mitigeur  
Einhebelmischer

Ø33,5 mm

360°

Ø25mm

60071	031	Chrome	355
60071	149	Finox	460
60071	707	Black Metal Brushed	560
60071	708	Copper Brushed	560

# GIU'

COLLECTION



BLACK METAL BRUSHED



#299 BLACK METAL BRUSHED



#031 CHROME



#149 FINOX



#708 COPPER BRUSHED



La collezione OFFICINE GESSI si arricchisce di una nuova serie che rivisita, in chiave moderna, i più classici modelli dell'industrializzazione dei primi del Novecento. Disponibile nelle classiche varianti girevole, estraibile e semi-industriale, OFFICINE V propone inoltre le versioni a due fori, tre fori e top-lever. Grazie alle particolari finiture, la collezione si integra perfettamente negli ambienti in stile "industrial chic".



OFFICINE GESSI Collection is enriched by a new series that revisits, in a modern key, the most classic models from the early twentieth century industrialization. Available in the classic swivelling, pull-out and semi-industrial alternatives, OFFICINE V also stands out for its two-hole, three-hole and top-lever versions. Thanks to the special finishes, the collection is perfectly integrated into the "industrial chic" room.



# OFFICINE V

DESIGN\_GESSI STYLE STUDIO  
GESSI PATENT

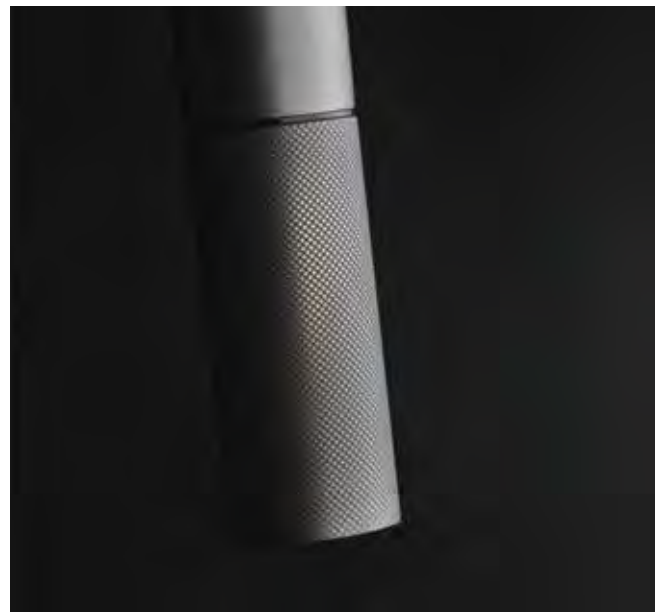



# OFFICINE GESSI - V



## INNOVAZIONE E STILE PER VIVERE LA CUCINA

Con un taglio deciso ma dalle forme morbide e slanciate, Gessi crea un nuovo codice estetico in cucina, coniugando creatività e raffinatezza in un seducente gioco di sinuosità.

## INNOVATION AND STYLE TO LIVE THE KITCHEN

With a decisive cut but with soft and slender shapes, Gessi creates a new aesthetic code in the kitchen, combining creativity and refinement in a seductive game of sinuosity.



DESIGN\_GESSI STYLE STUDIO  
GESSI PATENT

CHROME 031

MATTE BLACK 299

FINOX 149



FINOX/ MATTE BLACK

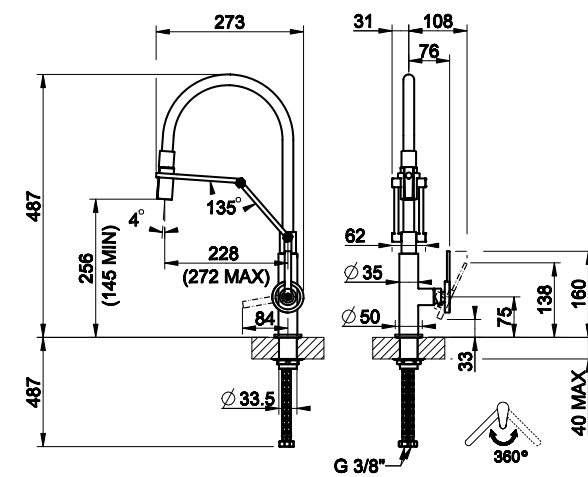

## 60205

Miscelatore semi pro monocomando  
 Semi- professional sink mixer  
 Mitigeur semi-professionelle  
 Semi-Pro Einhebelmischer

- 2
- Ø33,5 mm
- 360°
- Ø25mm

60205 031	Chrome	540
60205 149	Finox	715
60205 599	Finox / Matte Black	690



#599 FINOX/ MATTE BLACK

#031 CHROME

#149 FINOX





FINOX

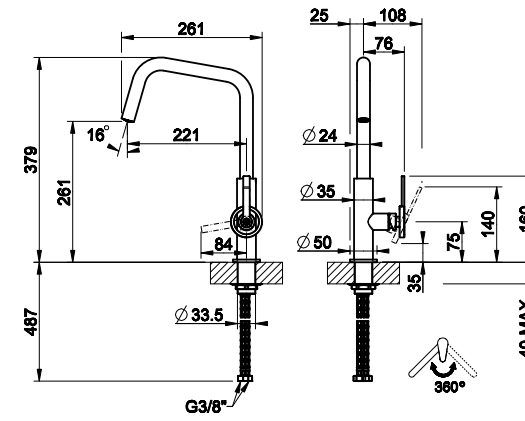

**60201**

Miscelatore monocomando  
Sink mixer  
Mitigeur  
Einhebelmischer

- Ø33,5 mm
- 360°
- Ø25mm

60201 031	Chrome	300
60201 149	Finox	400
60201 299	Matte Black	395

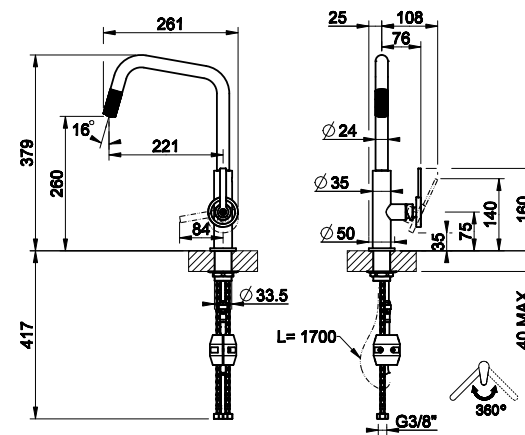

**60203**

Miscelatore monocomando  
Sink mixer  
Mitigeur  
Einhebelmischer

- 1
- Ø33,5 mm
- 360°
- Ø25mm

60203 031	Chrome	390
60203 149	Finox	490
60203 299	Matte Black	490



#149 FINOX

#031 CHROME

#299 MATTE BLACK

# OFFICINE

## COLLECTION

# GESI - V

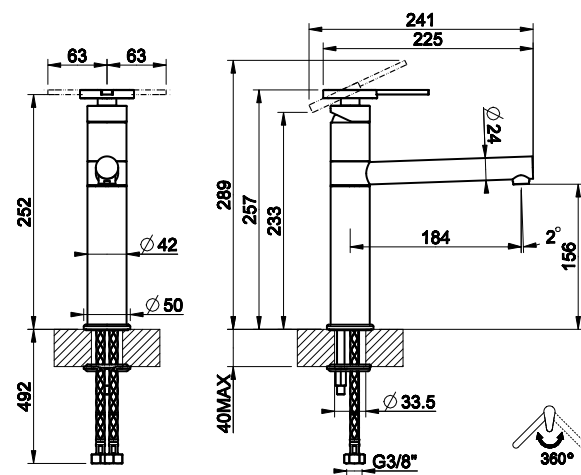

**60207**

Miscelatore monocomando  
Sink mixer  
Mitigeur  
Einhebelmischer

Ø33,5 mm

360°

Ø35mm

60207 031	Chrome	250
60207 149	Finox	310
60207 299	Matte Black	295



CHROME



#031 CHROME

#149 FINOX

#299 MATTE BLACK



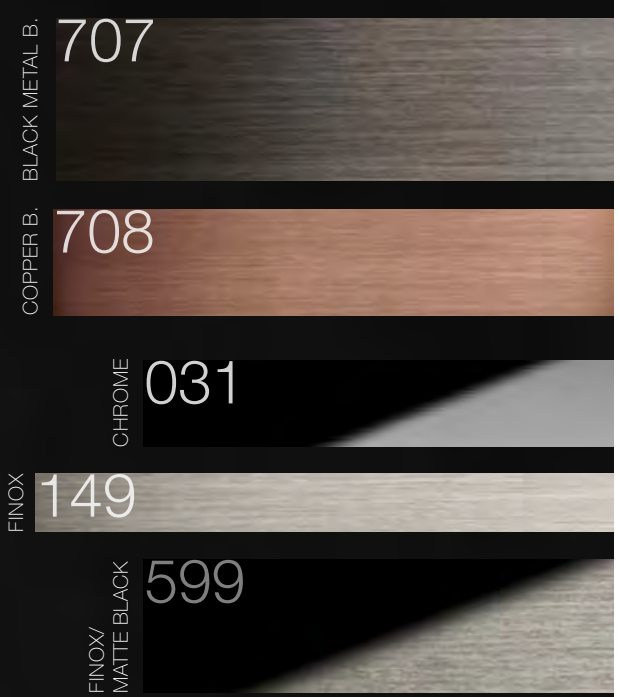

# Ispirazione “meccanica” per un nuovo “Design” dallo stile industrial chic

A “MECHANICAL” INSPIRATION FOR A BRAND  
NEW DESIGN WITH AN INDUSTRIAL CHIC STYLE

La ricerca della piacevolezza nei propri spazi privati, oggi porta a riqualificare gli ambienti funzionali dell’abitare, come la cucina, che rappresenta ormai, per concentrato di tecnologia, materiali disponibili e possibilità espressive, una quota preponderante del progetto di un’abitazione.

OFFICINE - GESSI



# OFFICINE



The research of pleasantness in one’s own private spaces leads, today, to the redevelopment of functional living spaces such as the kitchen. This room already represents a relevant part in the project of a house: it is a place full of technology and expressive possibilities.



La Collezione OFFICINE GESSI nasce dal diffuso trend dello stile "INDUSTRIAL" che negli ultimi anni ha influenzato l'interior di architetture abitative e commerciali, con la sua estetica caratterizzata dall'impiego di forme, superfici e materiali tipici degli ambienti di "produzione", dall'aspetto volutamente "grezzo".  
Un codice decorativo di grande fortuna per l'estrema versatilità arredativa, che permette di interpretarlo in modi sempre nuovi e personali.



# OFFICINE - GESSI

- CHROME 031
- FINOX 149
- FINOX/MATTE BLACK 599



OFFICINE GESSI collection has its roots in the popular trend of the "INDUSTRIAL" style that has been influencing the interior design of private and commercial architectures in the last years. With its aesthetics, characterized by shapes, surfaces and materials that are typical of "production" spaces with their willingly "rough" look, this decorative code has an extreme versatility that allows its interpretation in ways that are always more new and personal.

- COPPER B. 707
- COPPER B. 708



OFFICINE - GESSI



FINOX / MATTE BLACK



DESIGN\_GESSI STYLE STUDIO  
GESSI PATENT

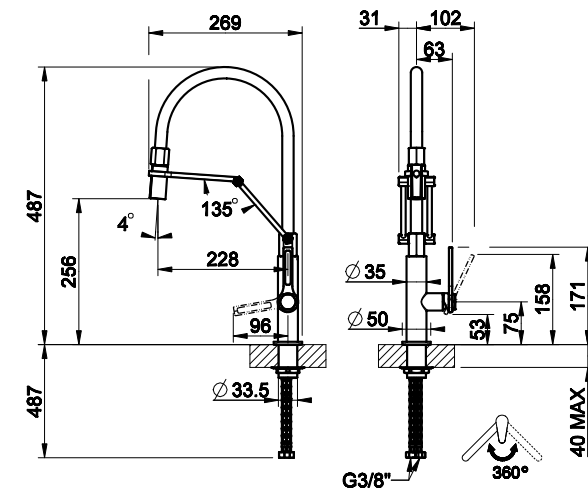

### 60055

Miscelatore semi pro monocomando  
Semi-professional sink mixer  
Mitigeur semi-professionnelle  
Semi-Pro Einhebelmischer

- 2
- Ø33,5 mm
- 360°
- Ø25mm

60055	031	Chrome	500
60055	149	Finox	665
60055	707	Black Metal Brushed	790
60055	708	Copper Brushed	790
60055	599	Finox / Matte Black	640





FINOX  
DESIGN\_GESSI STYLE STUDIO  
GESSI PATENT

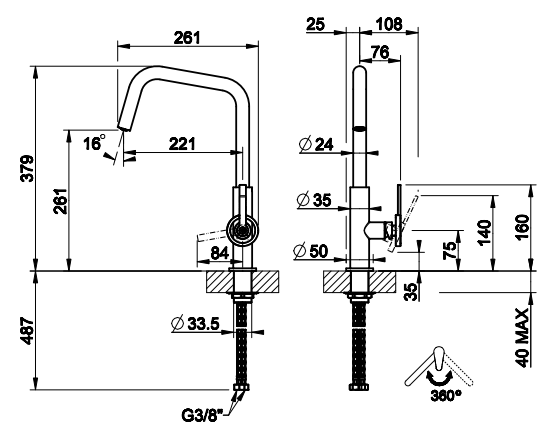

## 60051

Miscelatore monocomando  
Sink mixer  
Mitigeur  
Einhebelmischer

- Ø33,5 mm
- 360°
- Ø25mm

60051	031	Chrome	235
60051	149	Finox	295
60051	707	Black Metal Brushed	485
60051	708	Copper Brushed	485
60051	599	Finox / Matte Black	285

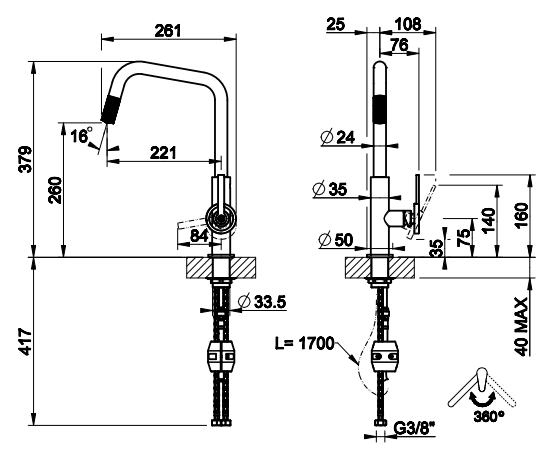

## 60053

Miscelatore monocomando  
Sink mixer  
Mitigeur  
Einhebelmischer

- 1
- Ø33,5 mm
- 360°
- Ø25mm

60053	031	Chrome	290
60053	149	Finox	365
60053	707	Black Metal Brushed	560
60053	708	Copper Brushed	560
60053	599	Finox / Matte Black	360



#149 FINOX    #031 CHROME    #707 BLACK METAL BRUSHED    #708 COPPER BRUSHED    #599 FINOX/ MATTE BLACK



FINOX  
MATTEBLACK  
599



DESIGN\_GESSI STYLE STUDIO  
GESSI PATENT

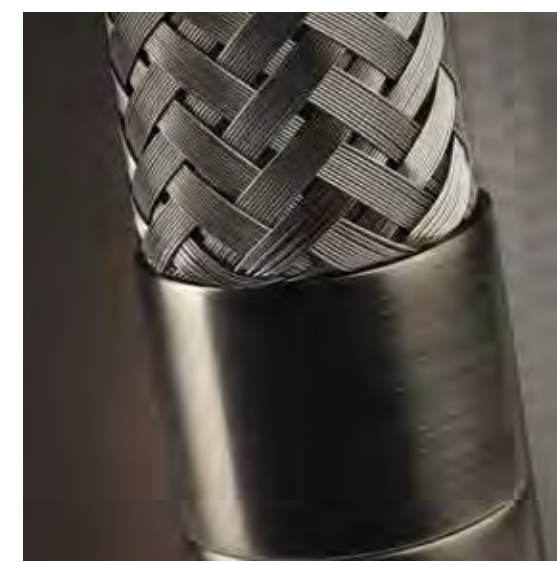

# MESH

**Taglio contemporaneo e forme slanciate**

CONTEMPORARY CUT AND SLENDER SHAPE

Con un taglio contemporaneo deciso e una forma slanciata, il tubo treciato in acciaio inossidabile di Mesh crea un miscelatore cucina inedito e giocosamente eccentrico. Si tratta di una coraggiosa espressione di design creativo e raffinato e di stile inconfondibile.

With a decisive contemporary cut and slender shape, the stainless-steel braided hose of Mesh makes an unprecedented and playfully eccentric kitchen tap. It is a plucky expression of creative, refined design and unmistakable style.



# Innovazione e stile per una vita migliore

INNOVATION AND STYLE FOR A BETTER LIFE



MESH







FINOX / MATTE BLACK

DESIGN\_GESSI STYLE STUDIO  
GESSI PATENT



DESIGN\_GESSI STYLE STUDIO  
GESSI PATENT

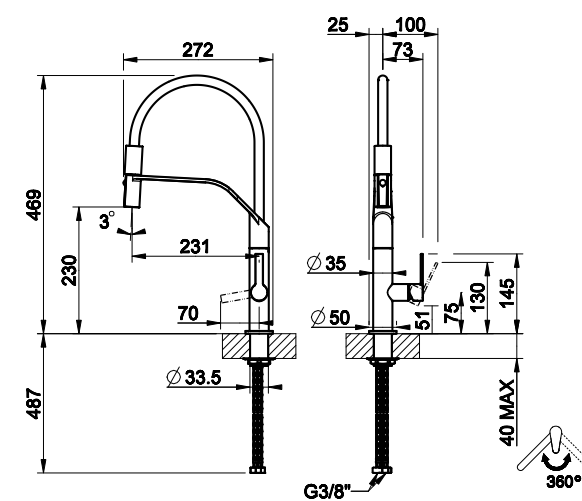

## 60005

Miscelatore semi pro monocomando  
Semi-professional sink mixer  
Mitigeur semi-professionnelle  
Semi-Pro Einhebelmischer

- 2
- Ø33,5 mm
- 360°
- Ø25mm

60005	149	Finox	515
60005	599	Finox / Matte Black	490



#599 FINOX / MATTE BLACK

#149 FINOX

MESH



FINOX / MATTE BLACK

DESIGN\_GESSI STYLE STUDIO  
GESSI PATENT

# MESH

DESIGN\_GESSI STYLE STUDIO  
GESSI PATENT

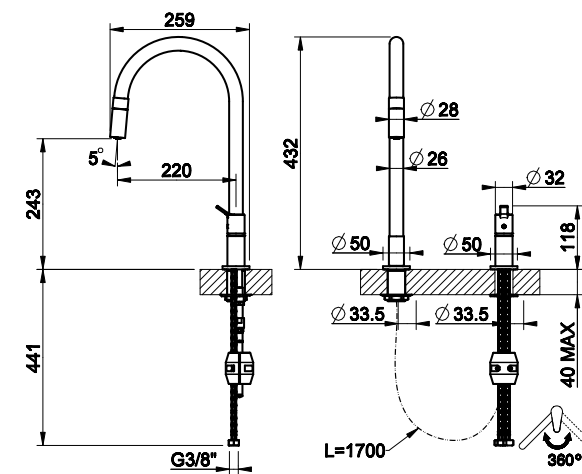

## 60001

Miscelatore monocomando  
Sink mixer  
Mitigeur  
Einhebelmischer

- 1
- 2 x Ø33,5 mm
- 360°
- Ø25mm

60001	149	Finox	535
60001	599	Finox / Matte Black	510



#599 FINOX/MATTE BLACK

#149 FINOX

MESH



# MESH



FINOX / MATTE BLACK

DESIGN\_GESSI STYLE STUDIO  
GESSI PATENT

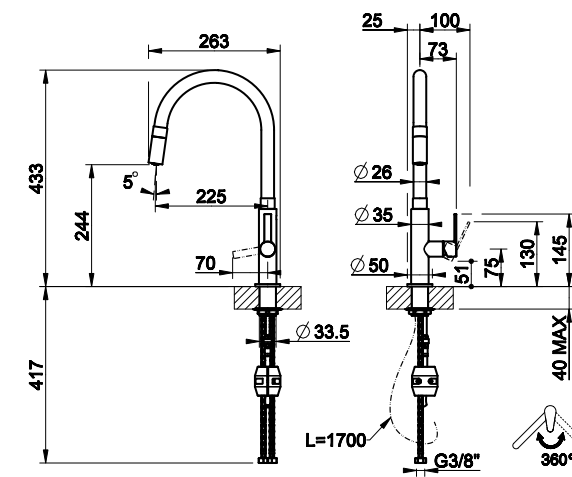

## 60003

Miscelatore monocomando  
Sink mixer  
Mitigeur  
Einhebelmischer

- 1
- Ø33,5 mm
- 360°
- Ø25mm

60003	149	Finox	495
60003	599	Finox / Matte Black	470



#599 FINOX/MATTE BLACK

#149 FINOX



DESIGN\_GESSI STYLE STUDIO  
GESSI PATENT

# INCISO

Tramite i contorni definiti, la superficie levigata e le varie finiture disponibili, la collezione si contraddistingue per un fascino accattivante in linea con la filosofia di Gessi, in una costante ricerca di arricchimento degli spazi abitativi con bellissimi oggetti che rimangono allo stesso tempo perfettamente funzionali.

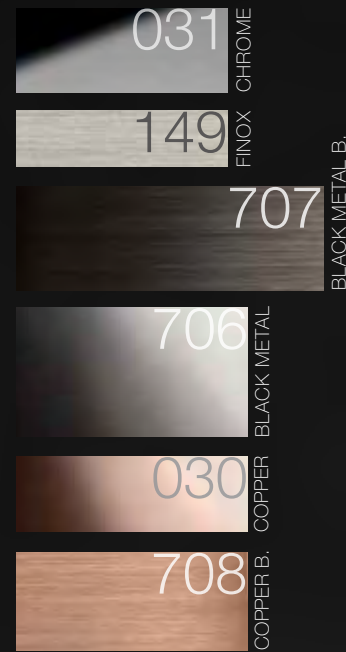

*David Rockwell*

La collezione di rubinetti e accessori disegnata da David Rockwell per Gessi ha lanciato un nuovo linguaggio di design per il mondo del living contemporaneo. Un prodotto dalle forme moderne e definite in linea con la tradizione di Gessi, altamente personalizzabile, versatile ed adatto a molti tipi di ambienti. Le caratteristiche dei primi impianti idraulici e la ricercata sensibilità dei moderni laboratori hanno ispirato il suo profilo distinto.

The collection of faucets and accessories designed by David Rockwell for Gessi creates a new design language for the world of contemporary living. The line's clean modern forms is consistent with the tradition of Gessi, and is highly customizable, fully flexible, suitable for many environments. The formal gestures of early plumbing fixtures and the refined, architectural sensibility of modern metalwork inspired the distinguished profile.



With sculpted contours paired with smooth surfaces and textured patterns, the collection achieves captivating allure in alignment with Gessi's philosophy, which is to enrich intimate living spaces with beautiful, well-made objects that remain reliably functional.





# INCISO

COLLECTION

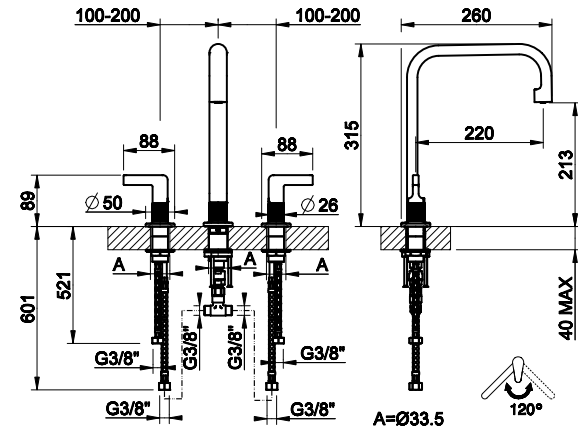

## 58701

Rubinetto tre fori  
Three hole mixer  
Mélangeur trois trous  
Dreiloch-Mischer

3 x Ø33,5 mm  
120°

58701	031	Chrome	715
58701	149	Finox	925
58701	706	Black Metal	1.050
58701	707	Black Metal Brushed	1.125
58701	030	Copper	1.050
58701	708	Copper Brushed	1.125
58701	710	Brass	1.125
58701	727	Brass Brushed	1.125
58701	735	Warm Bronze	1.125
58701	726	Warm Bronze Brushed	1.125
58701	299	Matte Black	895
58701	187	Aged Bronze	1.680
58701	713	Antique Brass	1.125
58701	246	Gold	1.125



BLACK METAL BRUSHED



#031 CHROME #149 FINOX #706 BLACK METAL #707 BLACK METAL BRUSHED #030 COPPER #708 COPPER BRUSHED #710 BRASS

#727 BRASS BRUSHED #735 WARM BRONZE #726 WARM BRONZE BRUSHED #299 MATTE BLACK #187 AGED BRONZE #713 ANTIQUE BRASS #246 GOLD

# INCISO

COLLECTION



BLACK METAL BRUSHED

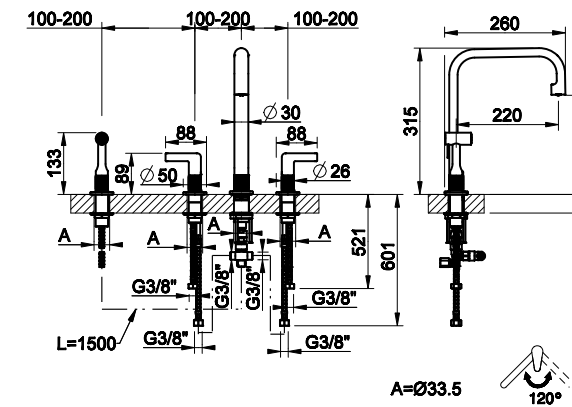

## 58703

Rubinetto quattro fori  
Four hole mixer  
Mélangeur quatre trous  
Vierloch-Mischer

- 1
- 4 x Ø33,5 mm
- 120°

58703 031	Chrome	1.065
58703 149	Finox	1.385
58703 706	Black Metal	1.575
58703 707	Black Metal Brushed	1.680
58703 030	Copper	1.575
58703 708	Copper Brushed	1.680
58703 710	Brass	1.680
58703 727	Brass Brushed	1.680
58703 735	Warm Bronze	1.680
58703 726	Warm Bronze Brushed	1.680
58703 299	Matte Black	1.330
58703 187	Aged Bronze	1.600
58703 713	Antique Brass	1.680
58703 246	Gold	1.680



#031 CHROME #149 FINOX #706 BLACK METAL #707 BLACK METAL BRUSHED #030 COPPER #708 COPPER BRUSHED #710 BRASS



#727 BRASS BRUSHED #735 WARM BRONZE #726 WARM BRONZE BRUSHED #299 MATTE BLACK #187 AGED BRONZE #713 ANTIQUE BRASS #246 GOLD



# PROTON

**Perfette proporzioni e forme pure**

PERFECT PROPORTIONS AND PURE SHAPES

L'impegno di Gessi per la sperimentazione e l'innovazione, ancora una volta si manifesta in un design che trascende il tempo e le mode.

Un profilo unico, elegante e fortemente identificativo, si realizza dall'incontro tra stile organico e geometrico, combinazione tra perfette proporzioni e forme pure. Il design estremamente innovativo di Proton fa sì che la collezione si inserisca con naturalezza e personalità in interni contemporanei che classici infondendovi uno speciale senso di relax.

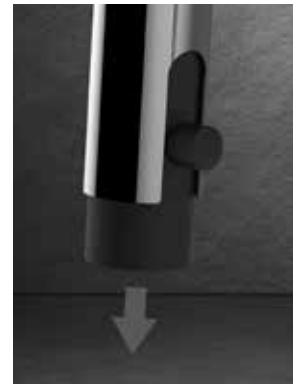

Gessi's commitment to creative experimentation and innovation once again manifests itself in a design that transcends time and trends.

A unique, elegant and strongly identifying profile is created by the combination of organic and geometric style, a combination of perfect proportions and pure shapes. Proton's extremely innovative design makes the Collection fit in both contemporary and classical interiors giving to any environment a special feel of relaxation.



DESIGN\_GESSI STYLE STUDIO  
GESSI PATENT

# PROTON

collection

CHROME 031

FINOX 149

MATTE BLACK 299



**COMBINANDO FORME PURE  
E PERFETTE PROPORZIONI,  
PROTON FONDE ARMONIA  
ED ERGONOMIA PER SEMPRE  
NUOVE SOLUZIONI D'INTERNI**

Lo stile minimalista e la massima attenzione ai dettagli, cifra stilistica di Gessi, riescono a trasmettere un messaggio di distinzione e di essenzialità.

Con Proton si rinnova ancora una volta l'identità unica del marchio e la sua capacità di trasformare lo spazio più creativo della casa in luogo invitante e confortevole, per una quotidianità condita da qualità, stile e piacere.



**COMBINING PURE  
SHAPES WITH PERFECT  
PROPORTIONS, PROTON  
MERGES HARMONY  
AND ERGONOMICS FOR  
INNOVATIVE INTERIOR  
SETTINGS**

The minimalist style and the attention to every detail that have made Gessi acclaimed on a world level, transmit a message of distinct and essential style. Proton renovates once again the brand's unique identity and its ability to transform the most creative space of the home into an inviting and comfortable place, for a daily life seasoned with quality, style and pleasure.





# PROTON

COLLECTION

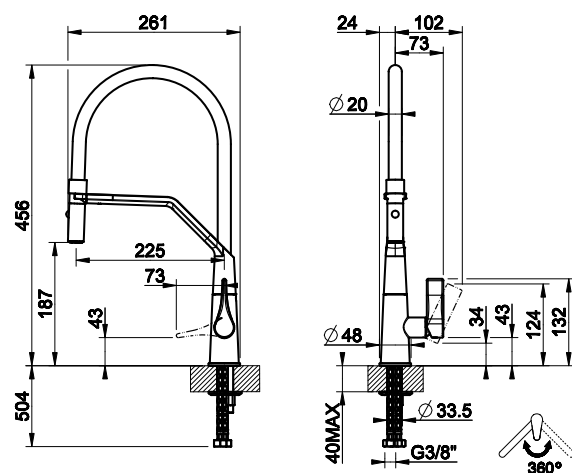

## 17191

Miscelatore semi pro monocomando  
Semi-professional sink mixer  
Mitigeur semi-professionnelle  
Semi-Pro Einhebelmischer

- 2
- Ø33,5 mm
- 360°
- Ø25mm

17191	031	Chrome	390
17191	149	Finox	460
17191	299	Matte Black	430

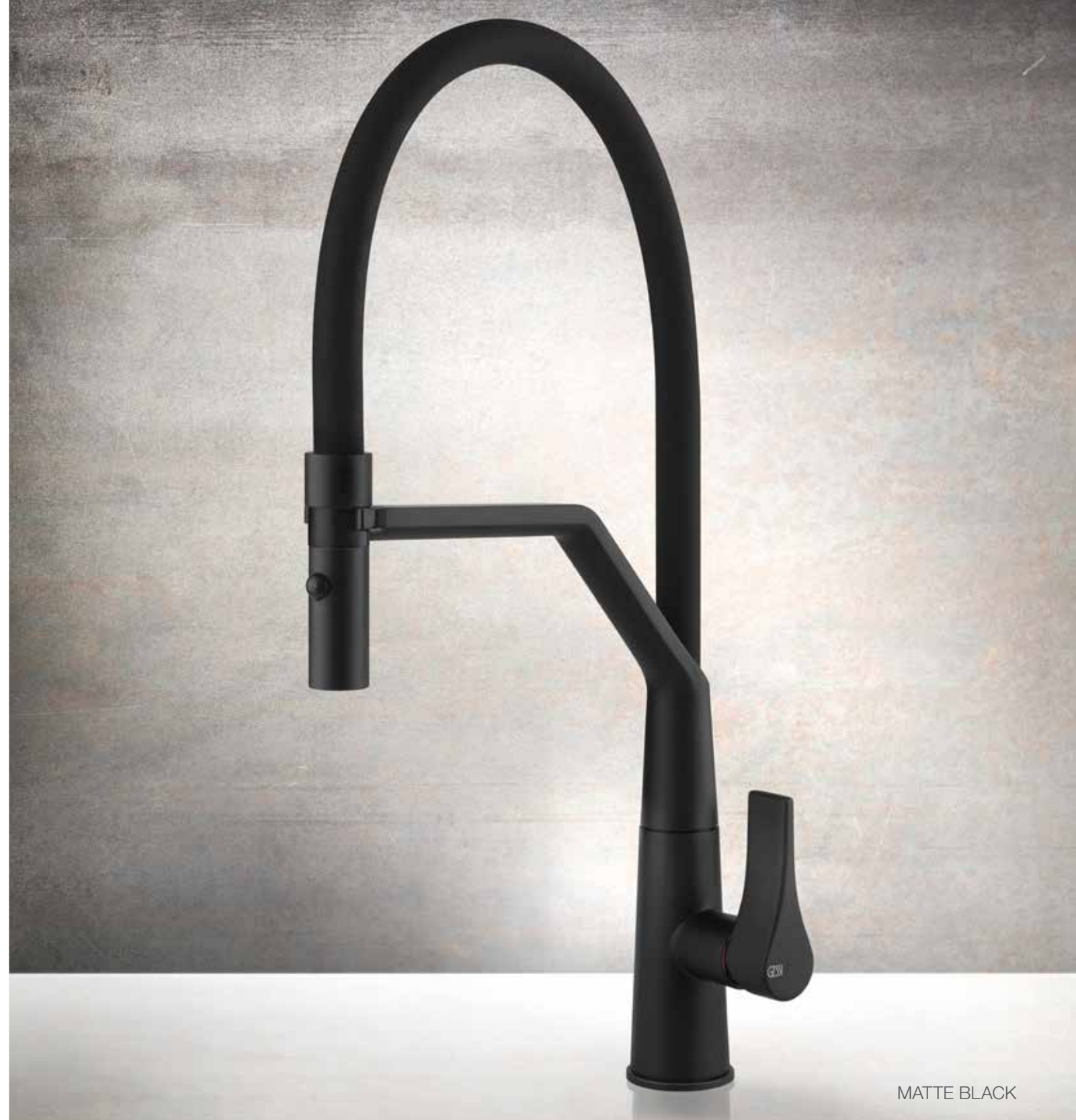

COLLECTION

PROTON

Soft shape  
for a linear  
design



CHROME



#299 MATTE BLACK

#031 CHROME

#149 FINOX

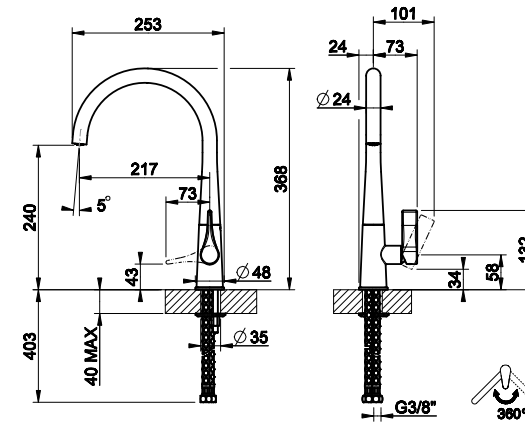

**17151**

Miscelatore monocomando  
Sink mixer  
Mitigeur  
Einhebelmischer

Ø33,5 mm

360°

Ø25mm

17151 031 Chrome 165

17151 149 Finox 225

17151 299 Matte Black 220

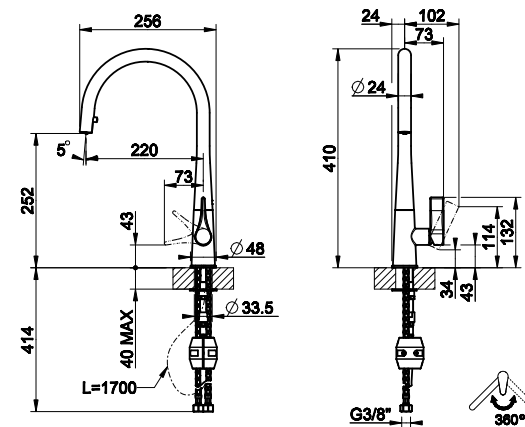

**17153**

Miscelatore monocomando  
Sink mixer  
Mitigeur  
Einhebelmischer

1

Ø33,5 mm

360°

Ø25mm

17153 031 Chrome 230

17153 149 Finox 295

17153 299 Matte Black 275



PROTON



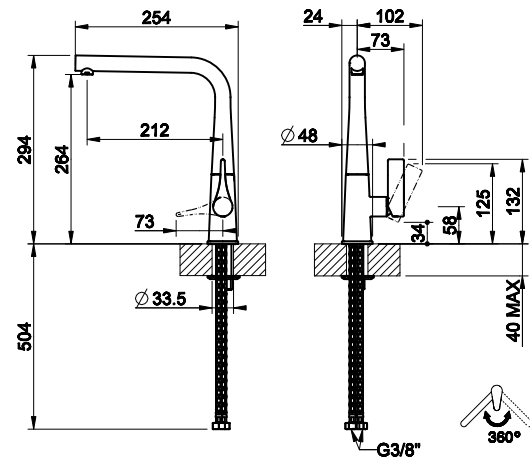

### 17175

Miscelatore monocomando  
Sink mixer  
Mitigeur  
Einhebelmischer

Ø33,5 mm

360°

Ø25mm

17175 031 Chrome 190

17175 149 Finox 240

17175 299 Matte Black 235

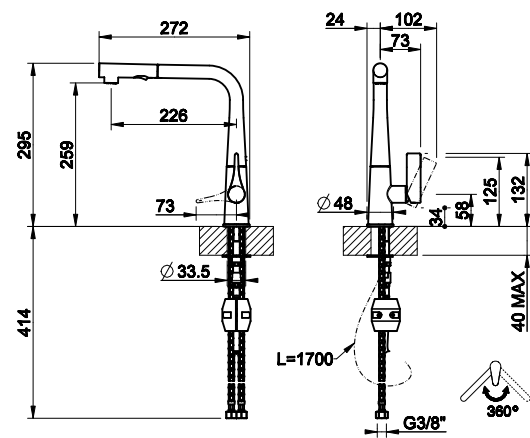

### 17177

Miscelatore monocomando  
Sink mixer  
Mitigeur  
Einhebelmischer

2

Ø33,5 mm

360°

Ø25mm

17177 031 Chrome 255

17177 149 Finox 325

17177 299 Matte Black 325

COLLECTION

PROTON



MATTE BLACK



#299 MATTE BLACK

#149 FINOX

#031 CHROME

# PROTON

COLLECTION



FINOX



#149 FINOX

#031 CHROME

#299 MATTE BLACK

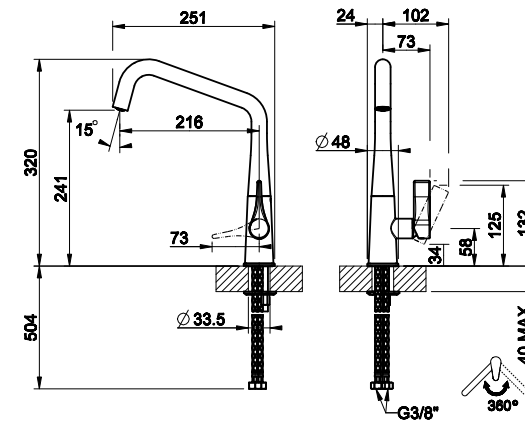

## 17179

Miscelatore monocomando  
Sink mixer  
Mitigeur  
Einhebelmischer

- Ø33,5 mm
- 360°
- Ø25mm

17179 031	Chrome	195
17179 149	Finox	245
17179 299	Matte Black	235

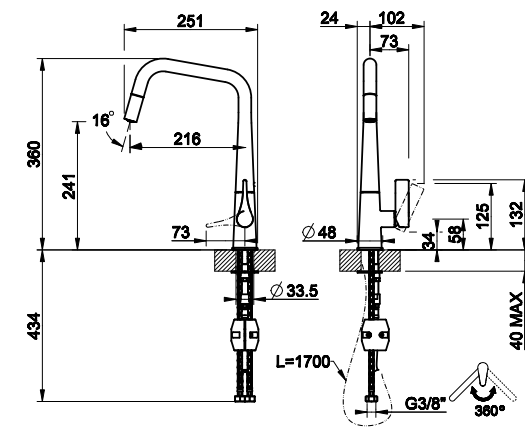

## 17171

Miscelatore monocomando  
Sink mixer  
Mitigeur  
Einhebelmischer

- 1
- Ø33,5 mm
- 360°
- Ø25mm

17171 031	Chrome	265
17171 149	Finox	330
17171 299	Matte Black	320

PROTON







# JUST COLOR

031

CHROME

149

FINOX





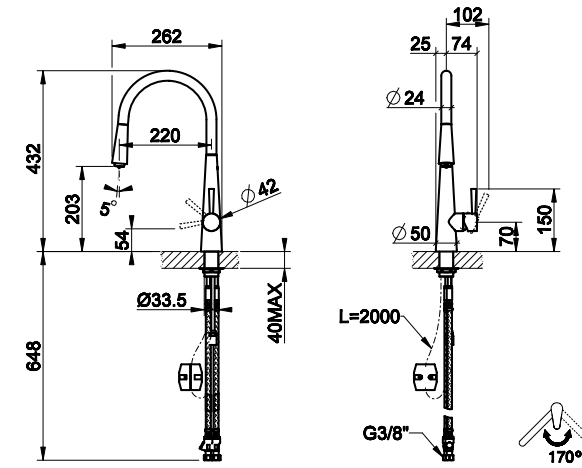

## 20587

Miscelatore monocomando - led di colore variabile  
 Sink mixer - changeable colour led depending on water temperature  
 Mitigeur - Couleur de l'eau déterminée par sa température réelle  
 Einhebelmischer - variables Farb-Led in Funktion der Wassertemperatur

- 1
- Ø33,5 mm
- 170°
- Ø35mm

20587	031	Chrome	915
20587	149	Finox	1.190



#031 CHROME



#149 FINOX



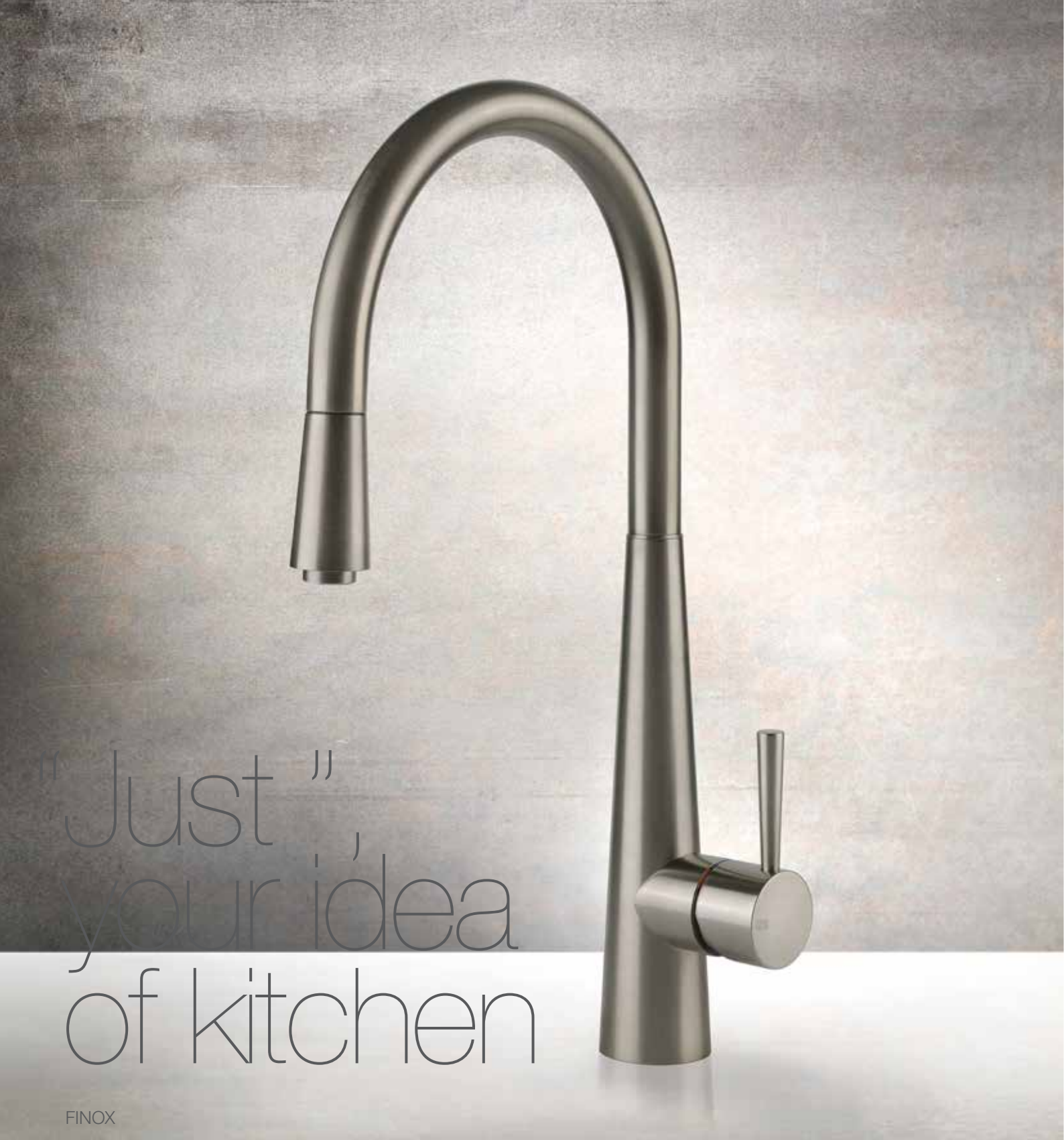

Just your idea  
of kitchen

FINOX

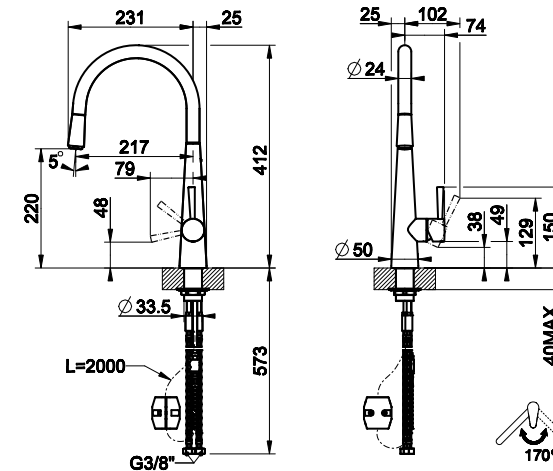

### 20577

Miscelatore monocomando  
Sink mixer  
Mitigeur  
Einhebelmischer

- 1
- Ø33,5 mm
- 170°
- Ø35mm

20577	031	Chrome	450
20577	149	Finox	570



#149 FINOX

#031 CHROME

The purity of steel

# LA PUREZZA DELL'ACCIAIO

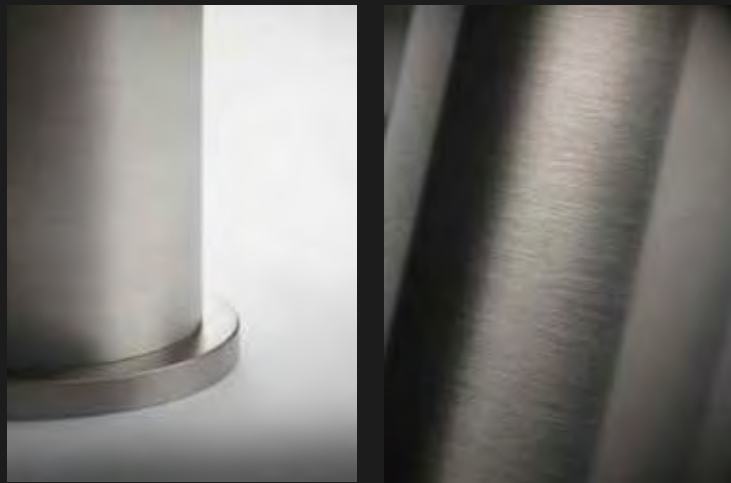

## La materia

Non molti materiali possono lodare una resistenza simile all'acciaio inossidabile, che non perde mai, in ogni condizione ambientale, il giusto splendore, la perfetta eleganza, il colore intenso, chiedendo anche una manutenzione davvero minima. Riciclabile al 100%, l'acciaio può essere rigenerato e riutilizzato per sempre, consentendo di ridurre il consumo di risorse naturali.

## Material

Not many materials can praise a resistant similar to the stainless steel, that never, in every environmental condition, loose the proper shining, perfect elegance, the rich color, asking also a really minimum maintenance. Recyclable 100%, steel can be regenerated and reused forever, permitting to reduce the consumption of natural resource.





# ACCIAIO

COLLECTION

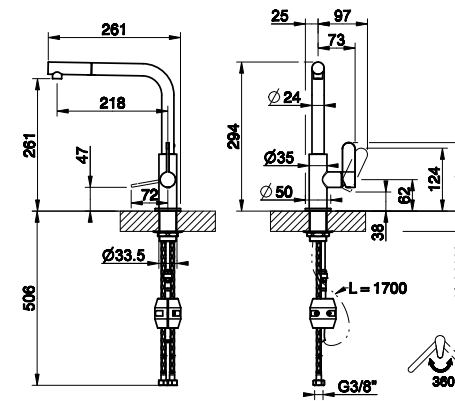

## 60537

Miscelatore monocomando  
Sink mixer  
Mitigeur  
Einhebelmischer

- 1
- Ø33,5 mm
- 360°
- Ø25mm

60537 239 Steel Brushed

330

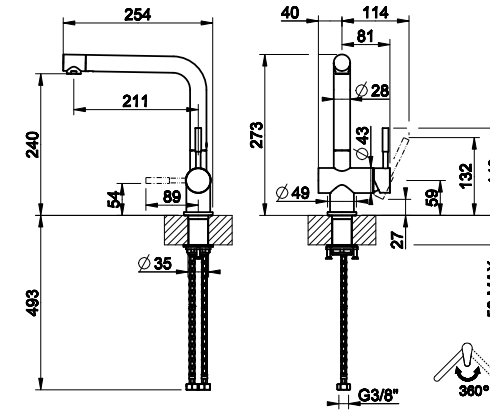

# ACCIAIO

COLLECTION



## 60496

Miscelatore monocomando con testina orientabile 120°  
Sink mixer with 120° rotation head  
Mitigeur avec tête orientable 120°  
Einhebelmischer mit verstellbarem Kopf 120°



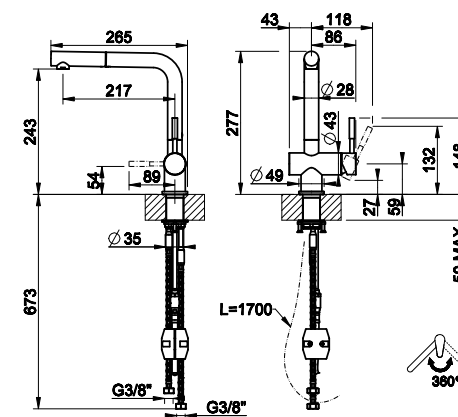

-  Ø33,5 mm
-  360°
-  Ø35mm

60496 239 Steel Brushed 290



## 60498

Miscelatore monocomando con doccetta estraibile  
Sink mixer with handshower  
Mitigeur douchette extractible  
Einhebelmischer mit Zugauslauf

-  2
-  Ø33,5 mm
-  360°
-  Ø35mm

60498 239 Steel Brushed 350







# HELIUM

collection



031  
CHROME

149  
299  
FINOX  
MATTE BLACK

# HELIUM

## COLLECTION



CHROME

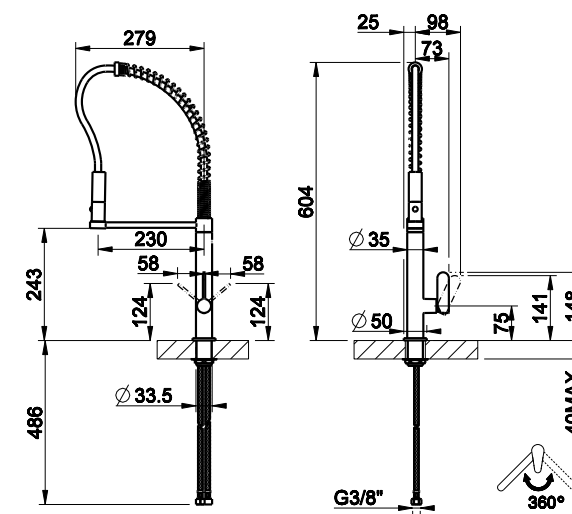

### 50011

Miscelatore semi pro monocomando  
Semi-professional sink mixer  
Mitigeur semi-professionnelle  
Semi-Pro Einhebelmischer

- 2
- Ø33,5 mm
- 360°
- Ø25mm

50011 031	Chrome	490
50011 149	Finox	635



#031 CHROME



#149 FINOX



# HELIUM

## COLLECTION



CHROME

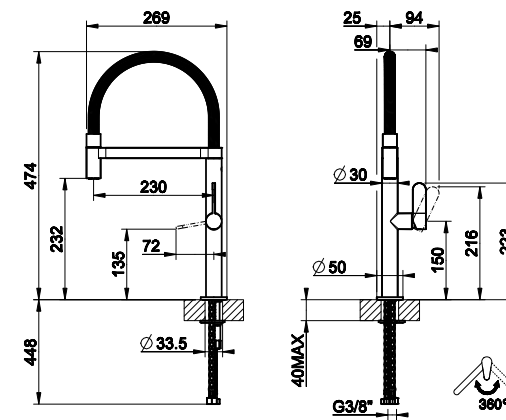

### 50009

Miscelatore semi pro monocomando  
Semi- professional sink mixer  
Mitigeur semi-professionnelle  
Semi-Pro Einhebelmischer

- 1
- Ø33,5 mm
- 360°
- Ø25mm

50009 031	Chrome	450
50009 149	Finox	575



#031 CHROME



#149 FINOX

COLLECTION

HELIUM



CHROME



#031 CHROME

#149 FINOX

#299 MATTE BLACK

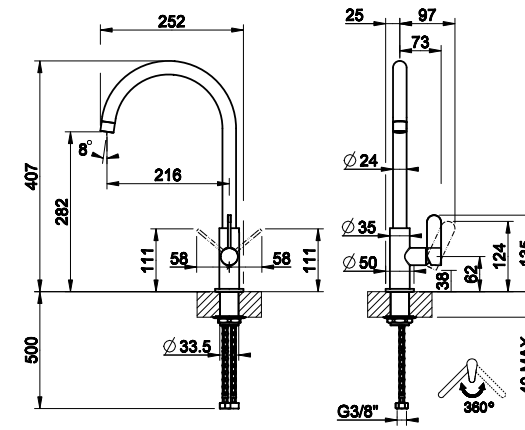

**60075**

Miscelatore monocomando  
Sink mixer  
Mitigeur  
Einhebelmischer

- Ø33,5 mm
- 360°
- Ø25mm

<b>60075 031</b>	Chrome	<b>200</b>
<b>60075 149</b>	Finox	<b>260</b>
<b>60075 299</b>	Matte Black	<b>235</b>

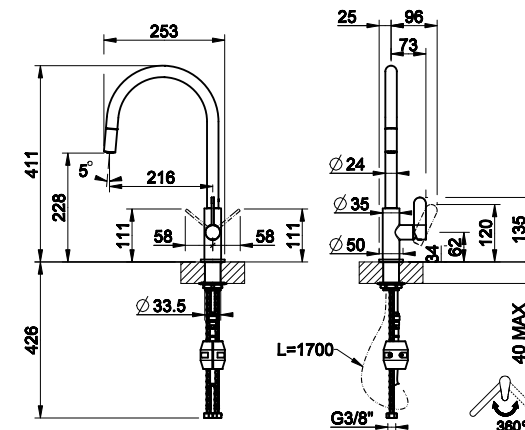

**60077**

Miscelatore monocomando  
Sink mixer  
Mitigeur  
Einhebelmischer

- 1
- Ø33,5 mm
- 360°
- Ø25mm

<b>60077 031</b>	Chrome	<b>270</b>
<b>60077 149</b>	Finox	<b>345</b>
<b>60077 299</b>	Matte Black	<b>305</b>

HELIUM





COLLECTION

HELIUM

MATTE BLACK



#299 MATTE BLACK

#149 FINOX

#031 CHROME

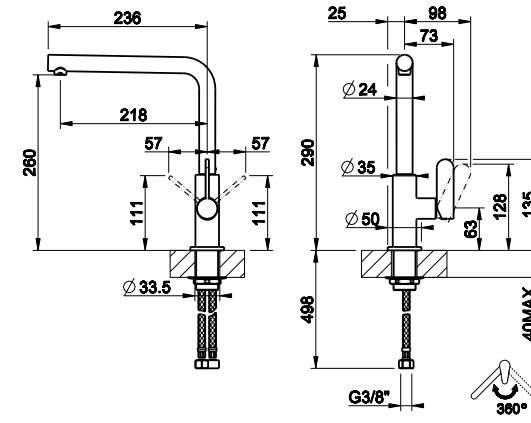

**50105**

Miscelatore monocomando  
Sink mixer  
Mitigeur  
Einhebelmischer

Ø33,5 mm

360°

Ø25mm

50105 031	Chrome	195
50105 149	Finox	260
50105 299	Matte Black	255

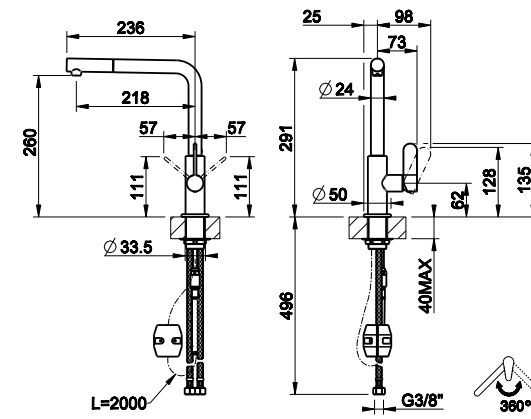

**50103**

Miscelatore monocomando  
Sink mixer  
Mitigeur  
Einhebelmischer

1

Ø33,5 mm

360°

Ø25mm

50103 031	Chrome	270
50103 149	Finox	345
50103 299	Matte Black	325



HELIUM

# HELIUM

## COLLECTION



CHROME

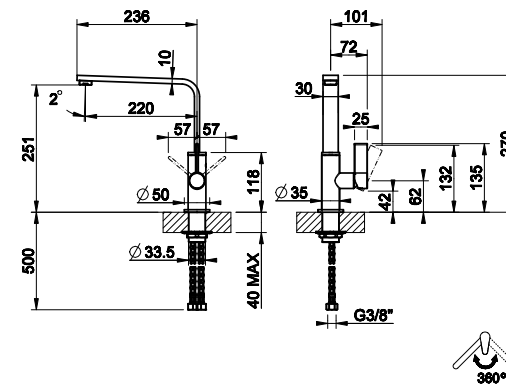

### 17015

Miscelatore monocomando  
Sink mixer  
Mitigeur  
Einhebelmischer

Ø33,5 mm

360°

Ø25mm

17015 031 Chrome

220

17015 149 Finox

280



#031 CHROME



#149 FINOX



# INCLINE

collection



148  
ART FOR CHEFS



CHROME 031

FINOX 149

MATTE BLACK 299

149  
ART FOR CHEFS

# INCLINE COLLECTION



MATTE BLACK

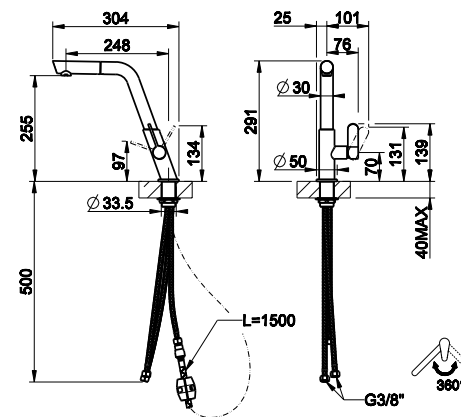

## 50007

Miscelatore monocomando  
Sink mixer  
Mitigeur  
Einhebelmischer

- 1
- Ø33,5 mm
- 360°
- Ø25mm

50007 031	Chrome	365
50007 149	Finox	475
50007 299	Matte Black	465



#299 MATTE BLACK



#031 CHROME



#149 FINOX



# INCLINE

COLLECTION

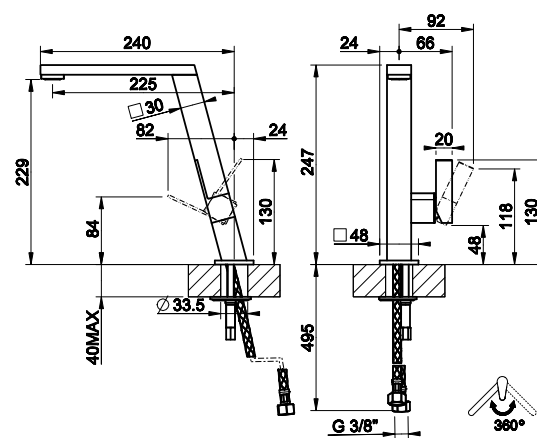

**17047**

Miscelatore monocomando  
Sink mixer  
Mitigeur  
Einhebelmischer

- Ø33,5 mm
- 360°
- Ø25mm

<b>17047 031</b>	Chrome	<b>390</b>
<b>17047 149</b>	Finox	<b>515</b>



FINOX



#149 FINOX

#031 CHROME

# OXYGENE

collection



031

CHROME

149

FINOX



# OXYGENE HT

COLLECTION



CHROME

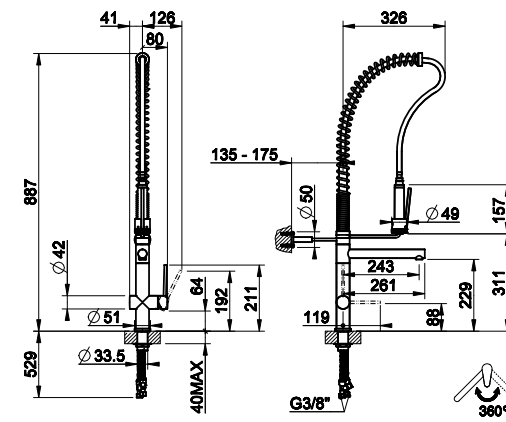

## 00941

Miscelatore professionale monocomando  
Professional sink mixer  
Mitigeur professionnelle  
Profi Einhebelmischer

- 1
- Ø33,5 mm
- 360°
- Ø35mm

00941 031	Chrome	980
00941 149	Finox	1.275



#031 CHROME



#149 FINOX

OXYGENE COLLECTION



CHROME

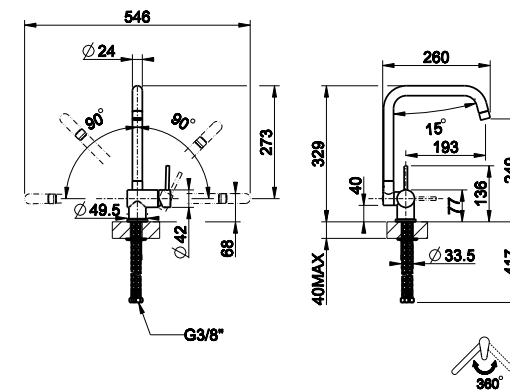

**50311**

Miscelatore abbattibile monocomando  
 Under-window sink mixer  
 Mitigeur à bec rabattable  
 Einhebelmischer mit klappbarem Schwenkarm

- Ø33,5 mm
- 36°
- Ø35mm

<b>50311 031</b>	Chrome	<b>305</b>
<b>50311 149</b>	Finox	<b>400</b>



#031 CHROME

#149 FINOX



# OXYGENE

COLLECTION



CHROME



#031 CHROME

#149 FINOX

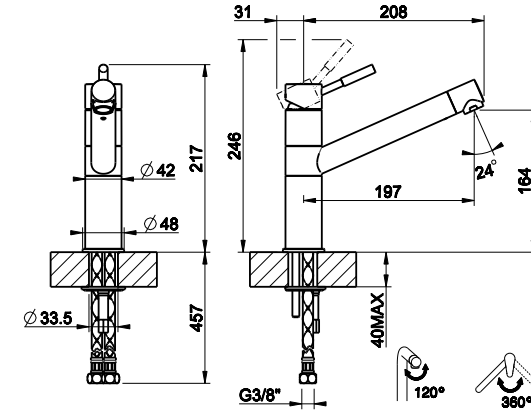

## 50301

Miscelatore monocomando con testina orientabile 120°  
Sink mixer with 120° rotation head  
Mitigeur avec tête orientable 120°  
Einhebelmischer mit verstellbarem Kopf 120°

Ø33,5 mm

360°

Ø35mm

50301 031 Chrome 245

50301 149 Finox 320

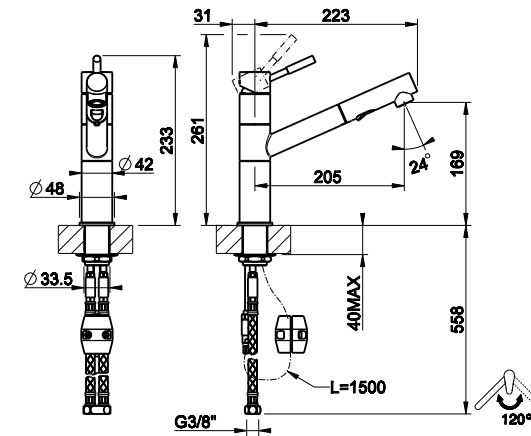

## 50303

Miscelatore monocomando  
Sink mixer  
Mitigeur  
Einhebelmischer

2

Ø33,5 mm

120°

Ø35mm

50303 031 Chrome 275

50303 149 Finox 355



# SU&GIU'

collection



031

CHROME

149

FINOX





# SU & GIU'

COLLECTION



CHROME



#031 CHROME

#149 FINOX

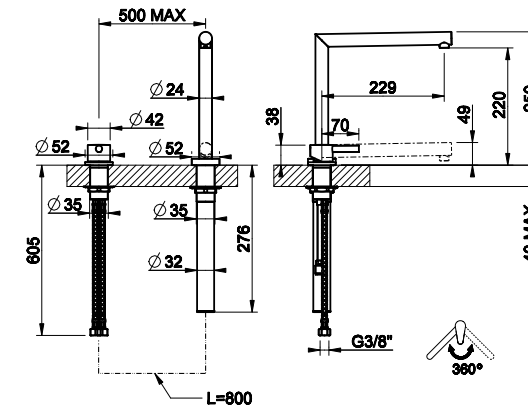

## 50107

Miscelatore con comando remoto e canna abbattibile  
Sink mixer with retractible spout and remote control  
Mitigeur à bec escamotable et manette de commande indépendante  
Einhebelmischer mit separater Bedienung

-  2 x Ø35 mm
-  360°
-  Ø25mm

50107 031	Chrome	400
50107 149	Finox	520

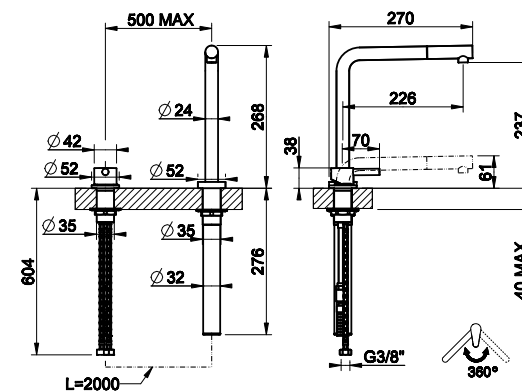

## 50109

Miscelatore con comando remoto e canna abbattibile  
Sink mixer with retractible spout and remote control  
Mitigeur à bec escamotable et manette de commande indépendante  
Einhebelmischer mit separater Bedienung

-  1
-  2 x Ø35 mm
-  360°
-  Ø25mm

50109 031	Chrome	375
50109 149	Finox	495



# TRADIZIONE

collection



031

CHROME



140

BRASS





# TRADIZIONE COLLECTION



BRONZE

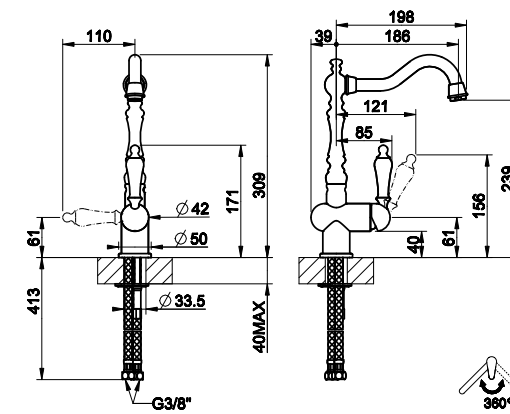

## 08744

Miscelatore monocomando  
Sink mixer  
Mitigeur  
Einhebelmischer

- Ø33,5 mm
- 360°
- Ø35mm

08744 031	Chrome	295
08744 149	Finox	375
08744 140	Bronze	375



#140 BRONZE



#149 FINOX



#149 CHROME

TRADIZIONE

# MONACO

collection





# MONACO

COLLECTION

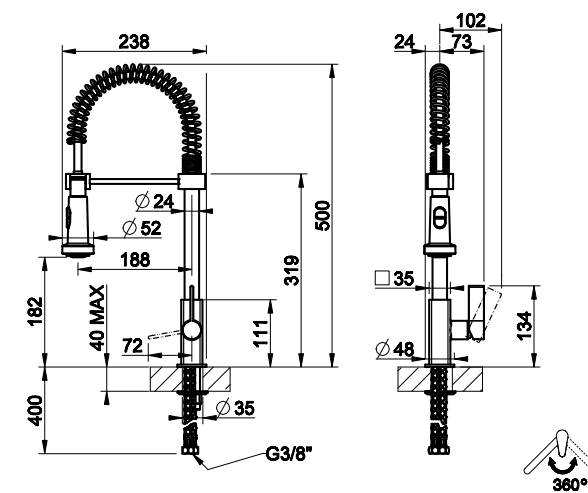

## 17157

Miscelatore semi pro monocomando  
Semi- professional sink mixer  
Mitigeur semi-professionelle  
Semi-Pro Einhebelmischer

- 2
- Ø33,5 mm
- 360°
- Ø25mm

17157 031 Chrome

295

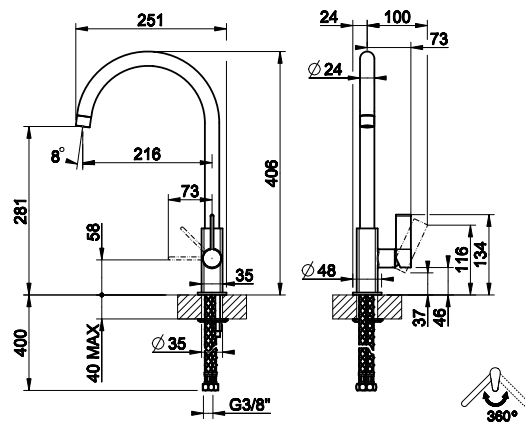

### 17159

Miscelatore monocomando  
Sink mixer  
Mitigeur  
Einhebelmischer

Ø33,5 mm

360°

Ø25mm

17159 031 Chrome

150

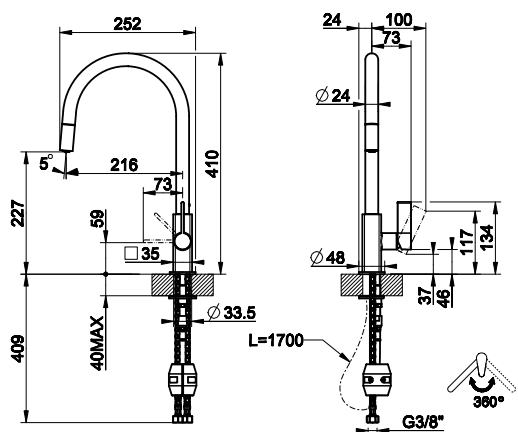

### 17163

Miscelatore monocomando  
Sink mixer  
Mitigeur  
Einhebelmischer

1

Ø33,5 mm

360°

Ø25mm

17163 031 Chrome

220

# MONACO

COLLECTION





# NEUTRON

collection





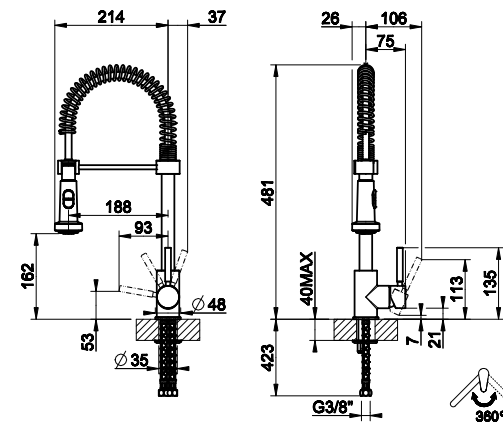

# NEUTRON

COLLECTION



## 50209

Miscelatore semi pro monocomando  
Semi-professional sink mixer  
Mitigeur semi-professionelle  
Semi-Pro Einhebelmischer

-  2
-  Ø33,5 mm
-  360°
-  Ø35mm

50209 031 Chrome

285





NEUTRON  
COLLECTION

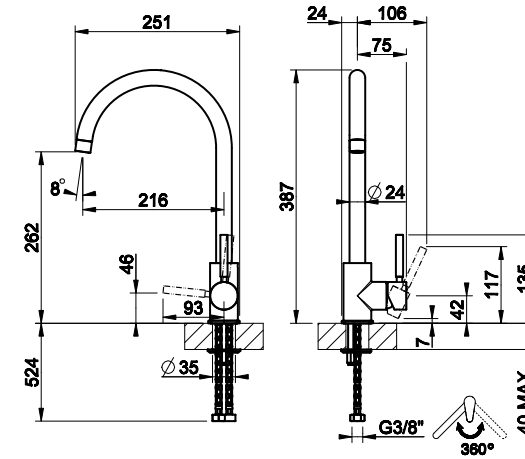

**20570**

Miscelatore monocomando  
Sink mixer  
Mitigeur  
Einhebelmischer

- Ø33,5 mm
- 360°
- Ø35mm

20570 031 Chrome

155

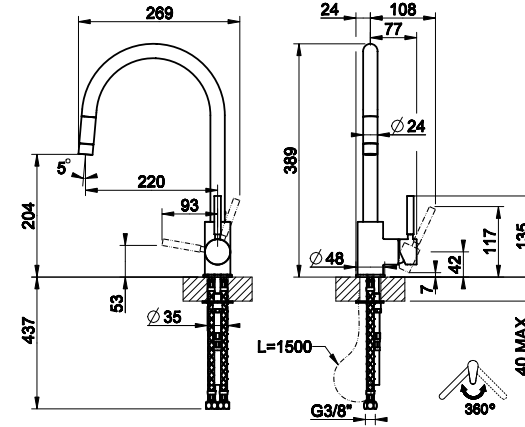

**17120**

Miscelatore monocomando  
Sink mixer  
Mitigeur  
Einhebelmischer

- 1
- Ø33,5 mm
- 360°
- Ø35mm

17120 031 Chrome

195



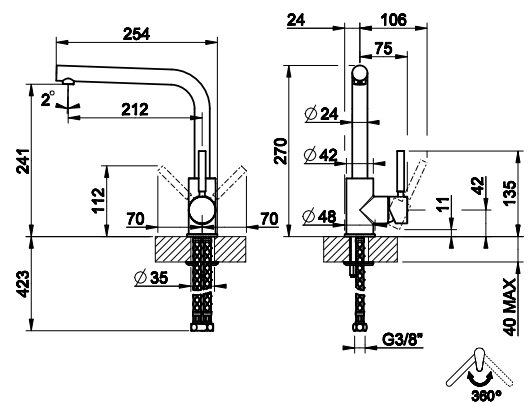

### 17155

Miscelatore monocomando  
Sink mixer  
Mitigeur  
Einhebelmischer

Ø33,5 mm

360°

Ø35mm

17155 031 Chrome

150

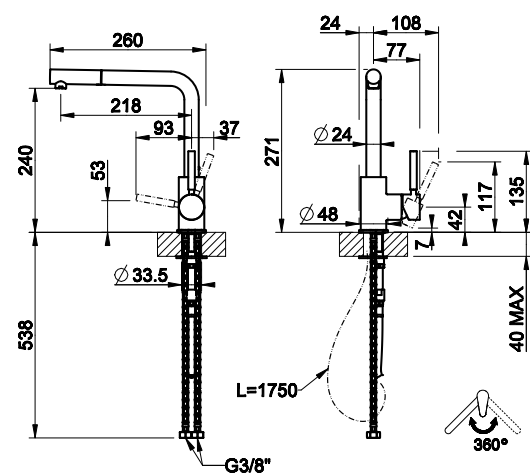

### 17169

Miscelatore monocomando  
Sink mixer  
Mitigeur  
Einhebelmischer

1

Ø33,5 mm

360°

Ø35mm

17169 031 Chrome

265

COLLECTION

NEUTRON





# NEUTRON

COLLECTION

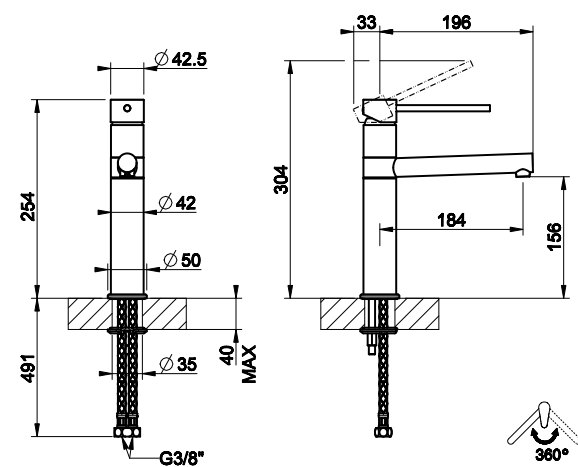

**17118**

Miscelatore monocomando  
Sink mixer  
Mitigeur  
Einhebelmischer

Ø33,5 mm

360°

Ø35mm

17118 031 Chrome

135



# CARY

collection



CHROME  
031



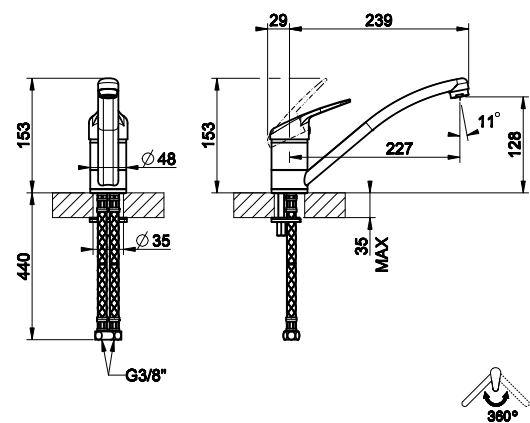

### 17114

Miscelatore monocomando  
Sink mixer  
Mitigeur  
Einhebelmischer

- Ø35 mm
- 360°
- Ø40mm

17114 031 Chrome

70

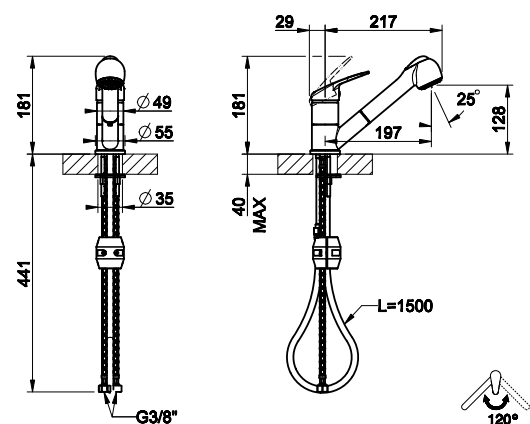

### 18971

Miscelatore monocomando  
Sink mixer  
Mitigeur  
Einhebelmischer

- 2
- Ø35 mm
- 120°
- Ø40mm

18971 031 Chrome

130



# CARY

COLLECTION



# CARY COLLECTION

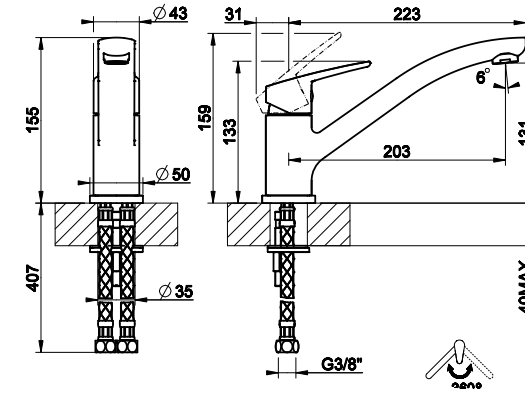

## 50407

Miscelatore monocomando  
Sink mixer  
Mitigeur  
Einhebelmischer

- Ø35 mm
- 360°
- Ø35mm

50407 031 Chrome 170

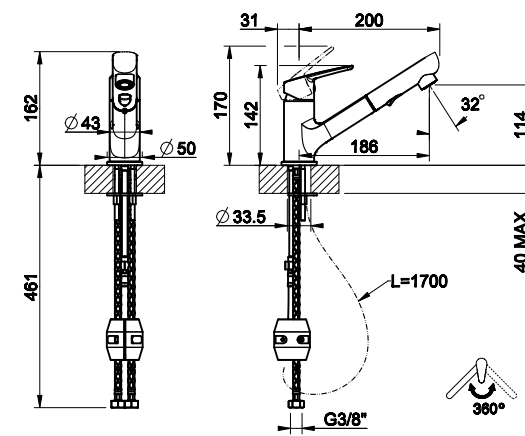

## 50413

Miscelatore monocomando  
Sink mixer  
Mitigeur  
Einhebelmischer

- 2
- Ø33,5 mm
- 360°
- Ø35mm

50413 031 Chrome 290





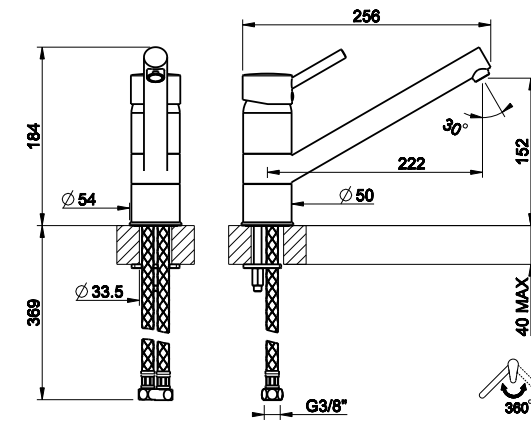

# CARY COLLECTION



## 17116

Miscelatore monocomando  
Sink mixer  
Mitigeur  
Einhebelmischer

-  Ø33,5 mm
-  360°
-  Ø40mm



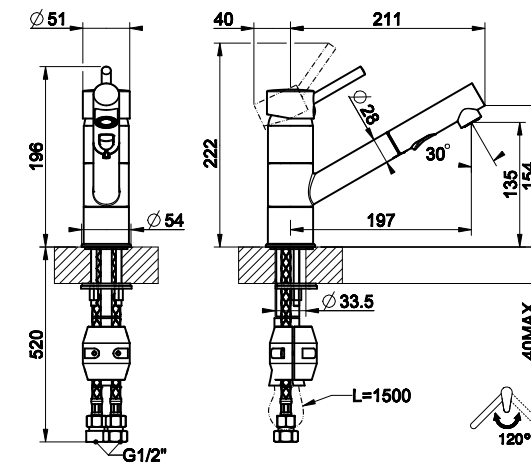

17116 031 Chrome

120



## 17173

Miscelatore monocomando  
Sink mixer  
Mitigeur  
Einhebelmischer

-  2
-  Ø33,5 mm
-  120°
-  Ø40mm

17173 031 Chrome

215





# SOAP DISPENSER



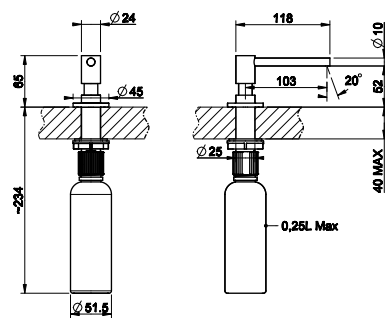

## 29660

Dispenser porta sapone da banco con carica dall'alto  
 Soap dispenser counter - charged by high  
 Distributeur de savon liquide  
 Spülmitteldispenser

Ø24mm

29660	239	Steel Brushed	265
29660	707	Black Metal Brushed	350
29660	708	Copper Brushed	350
29660	726	Warm Bronze Brushed	350
29660	727	Brass Brushed	370
29660	299	Matte Black	345

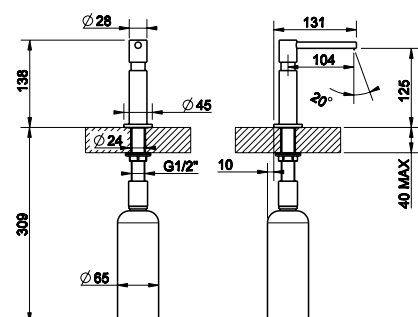

## 29651

Dispenser porta sapone da banco con carica dall'alto  
 Soap dispenser counter - charged by high  
 Distributeur de savon liquide  
 Spülmitteldispenser

Ø24mm

29651	031	Chrome	160
29651	149	Finox	205
29651	299	Matte Black	215
29651	706	Black Metal	255
29651	707	Black Metal Brushed	270
29651	030	Copper	255
29651	708	Copper Brushed	270
29651	710	Brass	280
29651	727	Brass Brushed	280
29651	735	Warm Bronze	280
29651	726	Warm Bronze Brushed	280
29651	187	Aged Bronze	280
29651	713	Antique Brass	280
29651	246	Gold	280

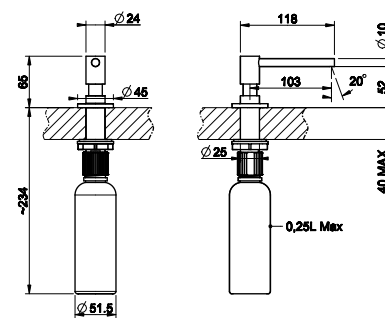

## 29658

Dispenser porta sapone da banco con carica dall'alto  
 Soap dispenser counter - charged by high  
 Distributeur de savon liquide  
 Spülmitteldispenser

Ø24mm

29658	031	Chrome	145
29658	149	Finox	185
29658	299	Matte Black	150
29658	125	Copper Brushed GHRC	205
29658	126	Black Metal Brushed GHRC	205

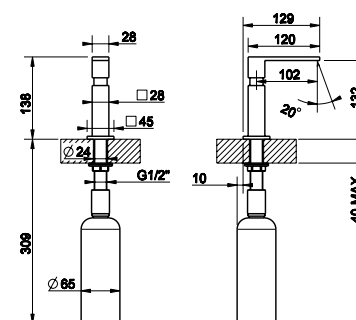

## 29653

Dispenser porta sapone da banco con carica dall'alto  
 Soap dispenser counter - charged by high  
 Distributeur de savon liquide  
 Spülmitteldispenser

Ø24mm

29653	031	Chrome	235
29653	149	Finox	300

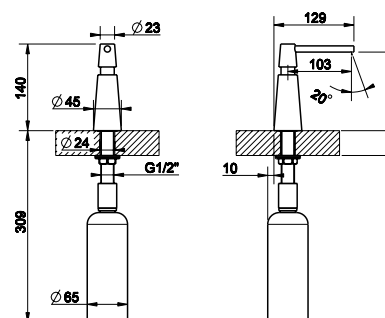

## 29654

Dispenser porta sapone da banco con carica dall'alto  
 Soap dispenser counter - charged by high  
 Distributeur de savon liquide  
 Spülmitteldispenser

Ø24mm

29654	031	Chrome	175
29654	149	Finox	230
29654	299	Matte Black	235



# INFORMAZIONI GENERALI

<b>CERTIFICATI DEL SISTEMA DI GESTIONE</b>	200
<b>PRESCRIZIONI TECNICHE</b>	201
<b>CONDIZIONI GENERALI DI VENDITA</b>	202



# CERTIFICATI DEL SISTEMA DI GESTIONE

## Gessi azienda etica tra qualità, persona e ambiente.

Impiegando tecnologie avanzate e talvolta creando processi innovativi, aderendo alle proprie severe politiche e andando spesso oltre le prescrizioni regolamentari, ogni giorno Gessi afferma il proprio obiettivo di preservare l'ambiente, di realizzare prodotti di impareggiabile qualità e di promuovere un luogo di lavoro salubre.

Sono questi i valori che stanno a cuore dell'azienda e che dovrebbero essere condivisi da tutti coloro che, come Gessi, intendono promuovere una cultura del prodotto che vada oltre le pure apparenze.

## Certificato del sistema di gestione: Ambiente



Gessi è da sempre attenta al tema di una produzione "verde". L'azienda è da anni seriamente impegnata nella ricerca e nello sviluppo di soluzioni tecnologiche e tecniche nei propri prodotti e processi, rivolte a ridurre i consumi e minimizzare l'impatto sull'ambiente, preservando tuttavia la cura attentissima all'estetica e proponendo ad ogni stagione design innovativi.

## Certificato del sistema di gestione: Sicurezza



La filosofia produttiva Gessi pone al centro del suo sistema ideale la persona e il perseguimento della qualità totale: di processo, di prodotto, del lavoro; con un'attenzione speciale all'ambiente dove l'uomo vive e lavora.

## Certificato del sistema di gestione: Qualità



Il valore aggiunto di una produzione genuinamente e integralmente "Made in Italy - Made in Gessi", emerge in ogni creazione Gessi.

# PRESCRIZIONI TECNICHE

- 1) al fine di garantire una lunga durata del prodotto installare rubinetti filtro a monte dell'impianto, da pulire periodicamente;
- 2) non installare il prodotto in presenza di pressione dell'acqua superiore ai 5 bar (nel caso, utilizzare un riduttore di pressione);
- 3) la temperatura dell'acqua non deve essere superiore ai 70°C;
- 4) effettuare il risciacquo delle tubazioni prima di installare il rubinetto;
- 5) per l'installazione attenersi a quanto indicato nelle istruzioni di montaggio allegate al prodotto;
- 6) non collegare la messa a terra di un impianto elettrico al flessibile o ad altra conduttura idraulica;
- 7) chiudere l'impianto in caso assenza prolungata per più di ventiquattro ore.

## MANUTENZIONE: INDICAZIONI PER LA PULIZIA DEI PRODOTTI GESSI S.p.A.

I prodotti GESSI S.p.A. sono manufatti di differenti materiali in aderenza a ogni esigenza di mercato, design e funzionalità. Le superfici della produzione di GESSI S.p.A. sono ottenute usando i migliori materiali, approvati processi produttivi e sono costantemente valorizzati da avanzati metodi di certificazione qualitativa. Per apprezzare appieno il Vostro prodotto GESSI e per preservarne la qualità estetica, considerate quanto segue:

- A) L'acqua contiene calcare in quantità variabili, il quale rimane trattenuto sulla superficie del prodotto, lasciando depositi dopo che l'acqua è evaporata. E' possibile prevenire le formazioni di depositi di calcare, e mantenere il Vostro prodotto pulito asciugandolo sempre con un panno morbido immediatamente dopo l'uso.
- B) NON DEVONO ESSERE UTILIZZATI DETERSIVI, SOLVENTI, AGENTI CHIMICI, SPUGNE ABRASIVE, PAGLIE METALLICHE, ALCOOL, ECC. che danneggerebbero irrimediabilmente le superfici del prodotto, compromettendone l'estetica, la lucentezza e la satinatura. PULIRE ESCLUSIVAMENTE CON ACQUA E SAPONE NEUTRO ASCIUGANDO CON PANNI MORBIDI.
- C) Pulire periodicamente il filtro dell'aeratore, dopo averlo smontato con attenzione, per rimuovere il calcare che ne ostruisce le uscite.
- D) Quando si usa sapone spray, spruzzare prima su un panno pulito o su una spugna, MAI direttamente sul prodotto.

L'azienda si riserva il diritto di invalidare la garanzia nel caso non venissero rispettate le condizioni di cui sopra, accertate da un tecnico della GESSI S.p.A.

Qualsiasi modifica alla presente garanzia potrà essere rilasciata solo dalla GESSI S.p.A. con apposita dichiarazione scritta. La garanzia non sarà, inoltre, operante in mancanza della documentazione comprovante la data di acquisto.

Eventuali danni e/o difetti di prodotti verranno eliminati in garanzia solo se l'articolo oggetto di reclamo sarà rimesso alla GESSI S.p.A. nella confezione originale allegando la prova di acquisto. La garanzia è estesa a tutti i paesi, esclusi Stati Uniti e Canada, in cui il prodotto è fornito dalla GESSI S.p.A. o dal suo distributore autorizzato. Sono in ogni caso esclusi dalla garanzia i costi per il montaggio e lo smontaggio del prodotto, le trasferte e gli interventi tecnici di personale specializzato, nonché gli oneri subiti dal cliente per l'indisponibilità e/o la sospensione dell'utilizzo del prodotto. Eventuali imperfezioni nelle finiture e nei materiali naturali, non sono da considerarsi difetti, ma caratteristica del prodotto per l'artigianalità della produzione.



# CONDIZIONI GENERALI DI VENDITA

- A** Con la trasmissione dell'ordine il Cliente accetta tutte le condizioni sottoesposte. Le vendite si intendono perfezionate solo dopo espressa approvazione della venditrice.
- B** I prezzi del presente listino si intendono IVA esclusa e sono espressi in euro. La venditrice si riserva la facoltà di modificare i prezzi, le condizioni generali di vendita e gli stessi prodotti (apportando cambiamenti ad articoli e/o finiture o eliminando addirittura lo stesso modello dal presente listino) in qualsiasi momento ed a suo insindacabile giudizio senza alcun obbligo di preavviso.
- C** I termini di consegna si intendono non perentori e, quindi, non vincolati per la venditrice. Conseguentemente il loro mancato rispetto non comporterà a carico della stessa alcun risarcimento per danno né legittimerà la compratrice a sospendere e/o ritardare i pagamenti pattuiti. Qualora il cliente debba fornire i dati necessari per eseguire la fornitura, il termine di consegna decorrerà dal giorno del ricevimento dei dati precisi. Quanto sopra include ritardi maggiori causati da calamità naturali, sommosse, scioperi, incendi e da altro evento imprevedibile.
- D** Il cliente è responsabile di tutti i dati di identificazione forniti alla venditrice quali Ragione Sociale – Sede Legale – Codice Fiscale – Partiva Iva e quant'altro specificatamente richiesto in materia della legislazione vigente. I dati del cliente, secondo la Legge 675 / 95, saranno custoditi ed elaborati per adempimenti degli obblighi di legge. Ogni altro utilizzo dovrà essere espressamente accettato dal cliente.
- E** La spedizione viene effettuata nel modo ritenuto più idoneo dalla venditrice. All'atto della consegna il cliente è tenuto alla verifica del materiale ordinato nonché al reclamo diretto al vettore in caso di manomissione o danneggiamento dell'imballo.
- F** Ogni reclamo e contestazione dovrà essere comunicato a mezzo lettera raccomandata entro e non oltre 8 giorni dalla data del ricevimento, con descrizione analitica del vizio, allegando foto a supporto della documentazione redatta, garanzia e scontrino / fattura d'acquisto. In caso di reclamo effettuato in tempo utile, la merce dovrà essere inviata in porto franco al magazzino della venditrice per la verifica dell'eventuale difetto. Nel caso di materiale riscontrato difettoso per cause imputabili alla venditrice, questa provvederà alla sostituzione del prodotto. E' esclusa ogni ulteriore responsabilità della venditrice per tutte le conseguenze dirette e indirette derivanti dall'installazione e dall'impiego dell'articolo.
- G** In ogni caso di ritardato pagamento verranno addebitati gli interessi convenzionali al tasso del 8% a decorrere dal giorno successivo alla scadenza senza ausilio di diffide. Al verificarsi di un mancato pagamento nei termini concordati, tutti gli ordini in portafoglio saranno sospesi senza necessità di preavviso e ritenuti annullati per colpa della ditta acquirente, fatto salvo il risarcimento dei danni. I pagamenti dei prodotti consegnati non saranno subordinati al completamento dell'ordine. Nessun pagamento potrà essere differito nel caso di contestazioni.
- H** Fino al momento in cui il venditore non abbia ricevuto il pagamento dell'intero prezzo dei prodotti, questi ultimi rimarranno di sua esclusiva proprietà. In caso di pagamenti dilazionati, le merci consegnate restano di proprietà del Venditore sino all'integrale pagamento del prezzo. Il Compratore si impegna a fare quanto necessario per rendere effettiva la riserva di proprietà, nella forma più estesa a favore del venditore. Si impegna, altresì, a collaborare con il Venditore nelle misure necessarie per la protezione del diritto di proprietà di quest'ultimo. Il Venditore è autorizzato

**I** a compiere, a spese del Compratore ogni formalità necessaria a rendere comunque opponibile ad ogni terzo la riserva di proprietà. Il compratore non può rivendere, cedere, costituire in garanzia la merce acquistata senza averne prima pagato integralmente il prezzo al venditore, al quale devono essere immediatamente rese note, a mezzo di lettera raccomandata, le procedure esecutive che, su istanza di terzi, avessero colpito dette merci.

**L** Le illustrazioni e le descrizioni contenute nel presente listino e negli stampati del venditore non comportano obbligo di fedele esecuzione; i dettagli e le misure contenute sono da considerarsi indicativi e soggetti a modifiche senza preavviso.

**M** Nel caso il Compratore non paghi quanto dovuto nei tempi prestabiliti o risulti inadempiente ad ulteriori obblighi presenti nelle condizioni di vendita e/o siglati con ulteriori scritti, il venditore ha la facoltà di risolvere qualsiasi rapporto di fornitura con effetto immediato, trattenendo a titolo di penale le relative somme già pagate, fatta salva ogni ulteriore richiesta di risarcimento del danno. Il tutto senza alcun onere penale o responsabilità nei confronti del Compratore.

Nell'ipotesi di controversia comunque dipendente da forniture effettuate dal venditore, sarà competente il Foro di Vercelli.

Eventuali errori e/o refusi di stampa del presente listino non costituiscono motivo di contestazione.

---

**I prezzi si intendono IVA esclusa**



GRAPHIC DESIGN —  
GESSI

PHOTOS —  
PROPERTY OF GESSI

© GESSI S.P.A.  
ALL RIGHTS RESERVED

KITCHEN MASTER  
<ED. APRIL 2021> COPYRIGHT © GESSI SPA

Le illustrazioni e le descrizioni contenute nel presente catalogo e negli stampati della venditrice non comportano obbligo di fedele esecuzione; i dettagli e le misure contenute sono da considerarsi indicativi e soggetti a modifiche senza preavviso. Eventuali errori e/o refusi di stampa del presente catalogo non costituiscono motivo di contestazione.

The images and descriptions included in our literature do not constitute an obligation of an accurate realization of the product, the details and the measurement included are to be used as a guide and maybe modified without notice.  
Possibile mistakes and/or misprints of current catalogue will not be object of dispute.

**GESSI** THE  
PRIVATE  
WELLNESS  
COMPANY®



GESSI SpA 捷仕  
Parco Gessi - 13037 Serravalle Sesia  
(Vercelli) ITALY  
Tel. +39 0163 454111  
Fax +39 0163 459273  
gessi@gessi.it

[www.gessi.com](http://www.gessi.com)



Download on the  
App Store



GET IT ON  
Google Play

ED. APRIL 2021  
GMCC04890



[gessi.com](http://gessi.com)