



 elica

Elica 2021

**4D LIVING EXPERIENCE**



ENTRA E SCOPRI  
LA QUARTA DIMENSIONE  
DI ELICA.

La versatilità delle funzioni, che spaziano dalla luce, all'aspirazione e alla cottura, si traduce in modelli nati per stupire. Scomporre il prodotto per scoprirne anime diverse e complementari, ciascuna essenziale nella sua funzione, permette di vivere l'oggetto con un'esperienza più completa.

La qualità dei materiali, l'attenzione ai dettagli, la passione per il design, isolati nella loro essenza, diventano protagonisti che trasmettono un'emozione.

Proprio quella emozione che rappresenta la quarta dimensione dei prodotti Elica.

COME ON IN AND DISCOVER  
ELICA'S FOURTH DIMENSION.

The versatility of the functions ranging from light to extraction and cooking translate into models with an innate wow factor. Taking the product apart to discover its diversified inner workings and accessories, each one essential for its operation, gives you the opportunity to get a much more comprehensive view of the object.

The quality of the materials, the attention to detail, the passion for the design, captured in their essence, become the key features which transmit an emotion.

The exact emotion that represents the fourth dimension of Elica products.



INQUADRA E SCOPRI  
FRAME AND DISCOVER

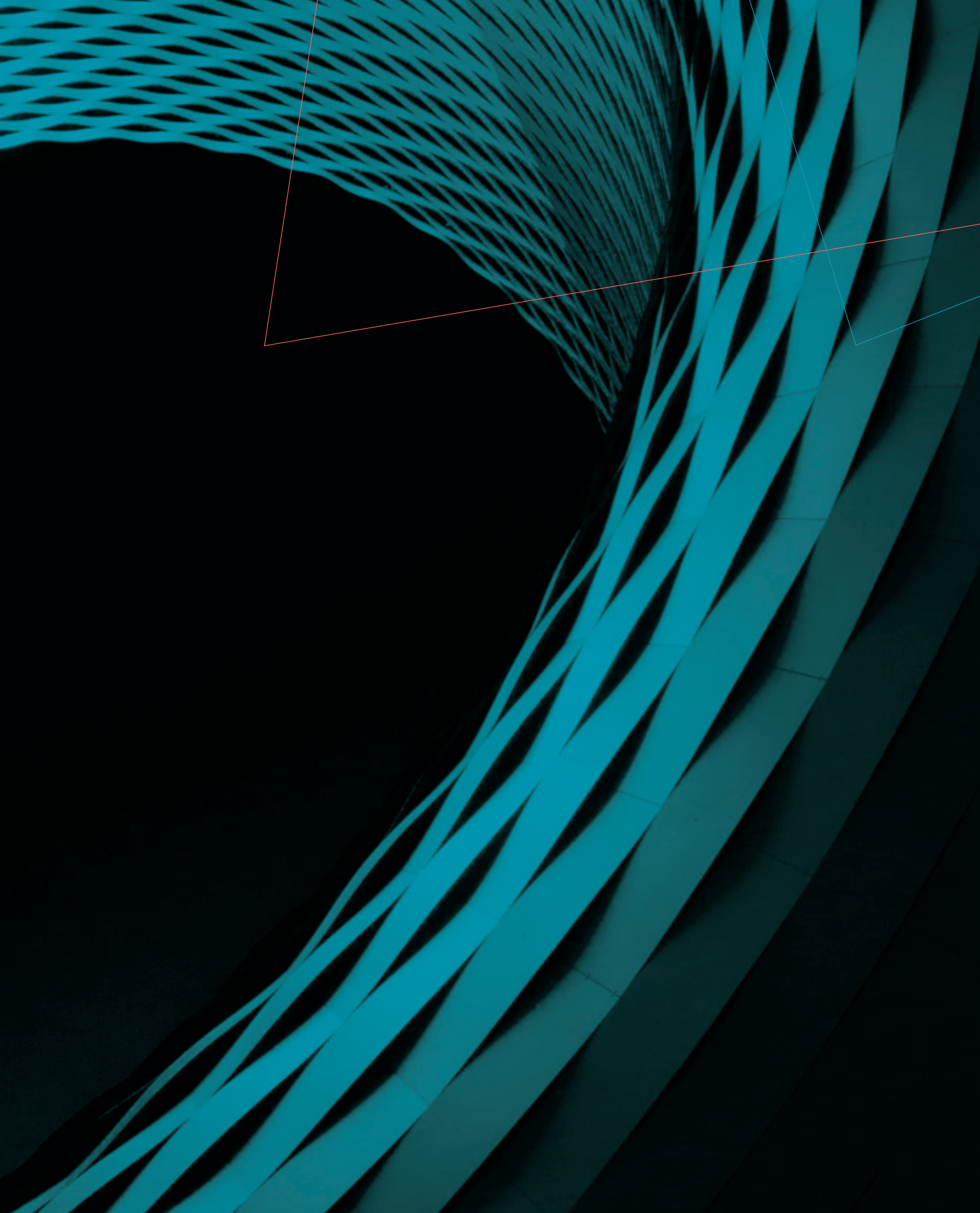

ELICA  
È STUPORE E PASSIONE,  
INNOVAZIONE E TRADIZIONE,  
INTUIZIONE E CORAGGIO.

Ci impegniamo ogni giorno per soddisfare e sorprendere i nostri clienti, con soluzioni che fondono design, esperienza, affidabilità, know how e stile.

Siamo nati in Italia nel 1970 e cresciuti nel mondo. Fin dall'inizio abbiamo applicato alle nostre cappe da cucina i principi del design italiano e abbiamo utilizzato gli strumenti tecnologici più innovativi. Lungo il corso degli anni abbiamo rivoluzionato l'immagine della cappa e il marchio Elica è entrato nelle case di tutto il mondo.

La nostra evoluzione ci ha portati a esplorare anche il campo della cottura con soluzioni sempre sorprendenti, nati da un'intuizione, un cambio di prospettiva che ha dato vita alla linea di piani aspiranti Nikola Tesla, vincitrice di numerosi premi internazionali, tra cui il celebre Compasso d'Oro ADI.

Oggi l'attenzione al dettaglio, il sapiente utilizzo dei migliori materiali e un approccio artigianale caratterizzano la nostra offerta e si traducono in gamme in cui la perfezione della produzione industriale si accosta alla grande esperienza artigianale, per dare vita a prodotti unici, in grado di sorprendere e di emozionare.

Tutte le nostre innovazioni sono nate con un unico scopo: stupire, emozionare e soddisfare i nostri clienti.

ELICA  
IS SURPRISE AND PASSION,  
INNOVATION AND TRADITION,  
INTUITION AND COURAGE.

Every day, we work to satisfy and surprise our customers with solutions that bring together design, experience, reliability, know-how and style.

We began life in Italy in 1970 and grew up in the world. From the very beginning, we applied the principles of Italian design to our kitchen hoods and we used the most innovative technological tools. Over the years, we have revolutionised the image of hoods and the Elica brand has become a household name worldwide.

Our evolution has led us to explore the field of cooking with surprising solutions, conceived from an intuition, a change of perspective that led to the creation of the Nikola Tesla line of aspirating induction hobs, winner of numerous international awards, including the renowned Compasso d'Oro ADI.

Today, attention to detail, the expert use of the best materials and an artisan approach are the hallmarks of our offer and translate into ranges in which the perfection of industrial production is combined with extensive artisan experience, to create one-of-a-kind products capable of surprising and thrilling.

All our innovations are created with one purpose: to amaze, thrill and make our customers happy.

# INDEX

10 Caratteristiche di prodotto  
Product Features

18 Elica Connect

20 NIKOLATESLA  
60 ARCH & LIGHTAIR

96 WALL

186 ISLAND

214 CEILING

238 SUSPENDED

274 DOWNDRAFT

286 BUILT-IN

316 **GOOD TO KNOW**

318 Accessori  
Accessories

319 Filtri odori  
Odour filters

324 Filtri grassi  
Grease filters

325 Motori remoti  
Remote motors

330 Approfondimenti performance  
Learn more about performance

337 Approfondimenti tecnici  
Technical informations

354 Tu e la cappa  
The hood and you

358 Etichetta energetica  
Energy label

359 Garanzia e service  
Warranty and service

## NIKOLATESLA 20



NIKOLATESLA  
FIT  
**50**



NIKOLATESLA  
ONE  
**34**



NIKOLATESLA  
FLAME  
**46**



NIKOLATESLA  
PRIME  
**42**



NIKOLATESLA  
LIBRA  
**38**

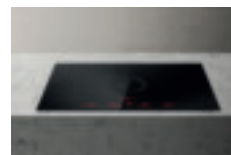

NIKOLATESLA  
SWITCH  
**30**

## ARCH & LIGHTAIR 60



IKONA MAXXI  
PURE  
**80**

ELICA **AIR PURE**



OPEN SUITE  
SUPERIOR  
**62**

ELICA **CONNECT**



NUAGE  
**88**



YE  
**92**



OPEN SUITE  
**70**

ELICA **CONNECT**

# WALL 96

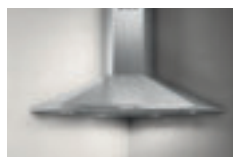

ACUTA  
182



ELLE  
162



MAJESTIC  
NO DRIP  
155



ADÉLE  
116



FLAT GLASS  
129



METEORITE  
109



APLOMB  
169



GALAXY  
121



MINI OM  
159



BELT  
163



HAIKU  
98



MISSY  
180



BIO  
104



HYDRA  
183



MOON  
111



BLOOM  
165



JOY  
120



OM AIR  
158



BLOOM-S  
150



KUADRA  
177



PLAT  
138



CIRCUS  
131



L'ESSENZA  
171

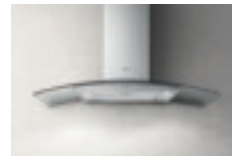

REEF  
130



CRUISE  
127



LOL  
123



RUBINO  
CORNER  
185



ELEKTRA  
170



MAJESTIC  
157



RULES  
142

WALL 



SHEEN-S  
172



STONE  
175



THIN  
122



SHIRE  
174



STRIPE  
167



TONDA  
178



SHY-S  
173



STRIPE  
URBAN  
166



TRIBE  
128



SINFONIA  
160



SUPER PLAT  
132  
ELICA CONNECT



TUBE PRO  
176



SPOT NG  
126



SWEET  
112



VEGA  
181



SPOT PLUS  
124



SYNTHESIS  
184



VERTIGO  
161



SPOT  
URBAN  
125



TAMAYA  
179



# ISLAND 186



ADÉLE ISLAND  
**201**



JOY ISLAND  
**202**



SPOT PLUS  
ISLAND  
**209**



BIO ISLAND  
**192**



KUADRA  
ISLAND  
**213**

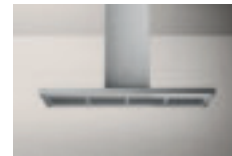

THIN ISLAND  
**208**



GALAXY  
ISLAND  
**203**



METEORITE  
ISLAND  
**197**



TRIBE ISLAND  
**210**



HAIKU ISLAND  
**188**



MOON ISLAND  
**199**



TUBE PRO  
ISLAND  
**212**



IKONA  
**204**



REEF ISLAND  
**211**

# CEILING 214



CLOUD SEVEN  
**235**



HILIGHT-X  
**233**



LULLABY@  
**220**  
ELICA CONNECT



HILIGHT GLASS  
**231**



ILLUSION  
**226**



SKYDOME  
**225**

## SUSPENDED 238



EASY UX  
263

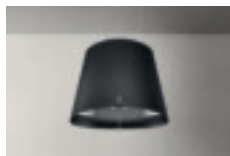

JUNO  
272



SHINING  
250



ÉDITH  
254



JUNO URBAN  
273



SUMMILUX  
246



IKONA LIGHT  
268



PIX  
264



WAVE UX  
258



INTERSTELLAR  
240



SEASHELL  
245

## DOWNDRAFT 274



GETUP  
276

ELICA CONNECT



PANDORA  
283

# BUILT-IN 286



BOXIN  
293



ERA  
305



KREA  
314



BOXIN  
NO DRIP  
289



ERA C  
304



LANE  
301



BOXIN  
PLUS  
292



ERA S  
303



LEVER  
310



CIAK  
311



ESTRAIBILE  
315



ELIBLOC  
302



GLASS OUT  
306



ELITE 14  
313



HIDDEN 2.0  
300



ELITE 35  
312



HIDDEN 2.0 @  
294

ELICA CONNECT



CARATTERISTICHE  
DI PRODOTTO

PRODUCT FEATURES

## ASPIRAZIONE / SUCTION



### CONNECTIVITY

Con la crescente diffusione del mondo IoT, è diventata ormai prassi comune governare i propri dispositivi grazie alla connessione wi-fi. Oggi possiamo comandare la nostra cappa tramite l'app Elica dedicata o attraverso vocal control per avviarla o spegnerla, regolarne la potenza aspirante o l'intensità e il colore della luce, semplicemente con un clic o con il supporto dei più diffusi vocal assistant. L'app diventa inoltre un utile strumento per la manutenzione del prodotto, grazie a periodiche notifiche che ne segnalano lo stato, eventuali operazioni di pulizia necessarie o l'esigenza di sostituire i filtri.

With the increasing widespread diffusion of the IoT world, it has become common practice to manage all your devices with a wi-fi connection. We can now control our extraction hood with the dedicated Elica app or through voice control to turn it on or off, adjust the extraction speed or intensity and the colour of the light, simply with a click or the help of the most popular vocal assistants. The app also becomes a useful tool for maintaining the product, thanks to periodic notifications which report on its status, any cleaning operations required or filters that need replacing.



### SPECIAL MATERIAL

Nella ricerca di prodotti belli da esibire ma funzionali nell'utilizzo quotidiano, i materiali giocano un ruolo chiave. Possono fare la differenza sia in termini di estetica, diventando protagonisti o scomparendo tra i mobili, che di facilità di manutenzione nel tempo. Fondamentali nel processo di innovazione, sono alla base di un look accattivante e di un'esperienza d'uso appagante. Elica seleziona materiali in cui durezza, facilità di pulizia e impatto estetico sono combinati in perfetto equilibrio. L'ampia selezione di finiture disponibili offre la massima libertà di scelta per ogni tipo di ambiente.

In the quest for attractive products to show off but which have a functional, everyday use, materials play a key role. They can make the difference by becoming an attractive signature feature or by disappearing into the background and by being easy to maintain in the long term. They are fundamental in the process of innovation, forming the basis of an attractive look and a fulfilling user experience. Elica selects materials in which sturdiness, easy cleaning and aesthetic impact are combined in a perfect balance. The wide selection of finishes available offers maximum freedom of choice whatever the setting.



### BACK ASPIRATION

Si ampliano le possibilità di installazione della tua cappa. Sui modelli dotati di questa funzione, è possibile ruotare il convogliatore e collegare direttamente la cappa con il muro posteriore oppure in altri modelli la particolare architettura del prodotto consente di realizzare l'uscita a muro tramite un curva a 90 gradi del tubo. In questo modo si può contare sulla massima aspirazione, preservando l'estetica originale del prodotto, che non verrà modificata da tubi o camini aggiuntivi a vista.

There are now more ways of installing your extraction hood. On models with this function, it is possible to rotate the conveyor and directly connected the hood with the outlet in the wall behind it or in other models, the special architecture of the product allows the wall outlet to be created with a 90-degree elbow pipe. Thus, you can rely on maximum extraction while preserving the original outward appearance of the product which will not be modified by pipes or additional visible flues.



### TOTAL INTEGRATION

Sempre più diffusa nelle cucine di oggi, la tendenza al total look garantisce un design omogeneo, uniforme e lineare rispetto allo spazio. I prodotti contrassegnati con Total Integration sono stati disegnati per essere integrati perfettamente nella cucina, mantenendo l'armonia dell'ambiente circostante.

The total look trend is becoming increasingly popular in kitchens now, guaranteeing a uniform, linear design with respect to the space. The Total Integration products have been designed to be seamlessly integrated into the kitchen whilst maintaining harmony with the surroundings.



## ASPIRAZIONE / SUCTION

**COMFORT SILENCE**

Con la diffusa tendenza di progettare la cucina a vista sul living, diventa importante poter contare su cappe che abbiano una grande capacità aspirante e che non siano rumorose, per non risultare invasive nell'ambiente circostante. Grazie alla tecnologia Comfort Silence il livello acustico delle cappe Elica alla massima velocità di aspirazione non disturba né interferisce con la conversazione tra i presenti.

With the widespread tendency to design open-plan kitchens joined to the living room, it has become important to be able to rely on hoods with a greater extraction capability which are quieter, so they do not intrude on the surroundings. Thanks to Comfort Silence, the sound level of Elica extraction hoods at maximum extraction speed does not disturb or interfere with the conversation of those present.

**SUPER EASY INSTALLATION**

Con l'esclusivo sistema Elica, il montaggio avviene in totale sicurezza e in pochissimi passaggi, salvaguardando l'estetica del prodotto e dello spazio in cui viene posizionato. Dopo il bloccaggio automatico del prodotto in sede, è possibile regolare al millimetro i punti di fissaggio, preservando il design lineare della cucina e assicurando la perfetta integrazione della cappa nell'ambiente. Una soluzione, facile, robusta e sicura.

With the exclusive Elica system, installation can be done in total safety in just a few steps, safeguarding the look of the product and the space in which it is positioned. After the hood is automatically locked in position, the fastening points can be finely adjusted to preserve the linear design of the kitchen and ensure perfect integration of the hood in the room. A simple, hard-wearing and safe solution.

**LONG LIFE FILTER**

Per assicurare una resa ottimale della cappa e la sua durabilità nel tempo bisogna sostituire i filtri tradizionali ogni 3/6 mesi. Per semplificare le attività di manutenzione Elica ha progettato l'innovativo filtro odore rigenerabile Long Life che consente una durata fino a 3 anni. È sufficiente lavarlo in acqua calda e sapone neutro o in lavastoviglie a 65° e asciugarlo in forno a 100° per 10 minuti ogni 2 mesi, per averlo sempre come nuovo. Il livello di efficienza si aggira intorno a 60%.

To ensure the best performance and long-term duration of your hood, the traditional filters must be replaced every 3-6 months. To simplify the maintenance operations, Elica has designed the innovative, regenerable Long Life odour filter which lasts up to three years. Just wash it with hot water and neutral soap or in the dishwasher at 65° and dry it in the oven at 100° for ten minutes every two months to keeping it looking good as new. The level of efficiency is about 60%.

**LONG LIFE FILTER ++**

Long Life Filter ++ è l'innovativo filtro studiato da Elica per la massima prestazione. Questo filtro garantisce un'efficienza di filtraggio che supera l'80%, contro una media del mercato che si ferma al 60%. Questo filtro odori ha la capacità di rigenerarsi e di durare fino ad un massimo di 3 anni, evitando così inutili sostituzioni e sprechi. Per mantenere tali caratteristiche, il filtro deve essere rigenerato ogni 2 o 3 mesi, basta lavarlo in acqua calda e sapone neutro o in lavastoviglie a 65 e asciugarlo in forno a 100° per 10 minuti, per averlo sempre come nuovo. La soluzione perfetta per chi si cimenta in cottura impegnative e prolungate.

Long Life Filter ++ is the innovative filter studied by Elica for maximum performance. This filter guarantees efficient filtering in excess of 80% against a market average of around 60%. This odour filter can be regenerated and lasts for up to a maximum of three years, thus avoiding frequent and wasteful replacements. To maintain these characteristics, the filter must be regenerated every two or three months in hot water and neutral soap or in the dishwasher at 65° and dried in the oven in the oven at 100° for ten minutes to keeping it looking good as new. The perfect solution if you like trying out challenging dishes which take a long time to cook.

## ASPIRAZIONE / SUCTION



### MULTI-D CAPTURE

Per chi in cucina si cimenta in preparazioni importanti e ha bisogno di un'aspirazione altamente efficiente, Elica ha studiato la soluzione Multi-d capture. L'aspirazione è distribuita in più aree per garantire una migliore captazione dei fumi. Il sistema fluidodinamico permette di incrementare la velocità di aspirazione grazie ad un opportuno dimensionamento delle superfici di passaggio dell'aria. Ciò garantisce un'alta efficienza di captazione dei fumi di cottura attraverso un aumento della depressione lungo tutto il perimetro del prodotto.

If you like a challenge when cooking and need highly efficient extraction capabilities, Elica has developed the Multi-d capture solution. The extraction is divided over multiple areas to guarantee the best fume capture capability. The fluid dynamic system allows you to increase the extraction speed by suitably sizing the surfaces through which the air passes. This guarantees a high cooking fume-capture efficiency through an increase in the negative pressure along the outside of the product.



### DIM LIGHT

La luce in cucina, così come in ogni ambiente domestico, rappresenta una leva progettuale importante per vivere al meglio i propri spazi. Modulare la giusta intensità diventa fondamentale per ricreare l'atmosfera desiderata. Ecco perché Elica ha progettato la funzione Dim Light, che permette di regolare la potenza luminosa della propria cappa attraverso un semplice comando. Luce al massimo per avere la migliore visibilità sul piano da lavoro, o soffusa per goderci momenti di relax.

The light in the kitchen, as in any room, is a key design feature for improving the home living experience. Achieving the right intensity becomes fundamental in creating the desired atmosphere. Which is why Elica has designed the Dim light function which allows you to adjust the intensity of your extraction hood light with a simple control. Maximum light for the best visibility on the worktop or dimmed when relaxing.



### TUNE WHITE

L'illuminazione in casa non può essere statica, perché a seconda dei momenti della giornata, abbiamo bisogno di toni di luce differenti: una luce fredda è ottimale per cucinare, così come una calda ricrea un mood più rilassato. La funzione Tune White permette di regolare il colore dei led dal bianco caldo (2400 k) fino al bianco freddo (5000 k). Con Tune White è possibile allineare il colore della luce proveniente dalla cappa con il resto delle luci presenti nell'ambiente, per una atmosfera uniforme in tutta la stanza.

Lighting in the home should not be static because different tones of light are called for depending on the time of day: cool light is excellent for cooking while warm light creates a more relaxing mood. The Tune White function allows you adjust the LED colour from warm white (2400 k) up to cool white (5000 k). With Tune White, you can also align the colour of the light from the hood with the rest of the lights in the room for a uniform atmosphere throughout.



## ASPIRAZIONE / SUCTION

**EASY TO MAINTAIN**

Mantenere la propria cappa pulita non solo garantisce la massima igiene in cucina, ma assicura una vita più lunga al prodotto. I modelli Elica sono progettati con materiali e finiture che rendono le operazioni di manutenzione immediate. Tutte le componenti, come i filtri grassi e odori, sono facilmente raggiungibili e rimovibili, per poterli lavare o sostituire velocemente.

Keeping your hood clean not only ensures maximum hygiene in the kitchen but also long life for the product. The Elica models are designed with materials and finishes for instant maintenance operations. All the components, such as the grease and odour filters, can be easily accessed and removed so they can be washed or rapidly replaced.

**AIRMATIC**

Oggi grazie a Airmatic il tuo piano aspirante è completamente automatico. Il suo sensore intelligente è in grado di distinguere la qualità dei fumi e i tipi di cottura e di abbinare queste informazioni al numero e alla potenza delle zone a induzione utilizzate. Anche quando il piano cottura è spento il sistema si adatta autonomamente diminuendo gradualmente l'aspirazione e eliminando i vapori e gli odori residui. Questa tecnologia avanzata rappresenta un'eccellenza nel mondo dei piani cottura aspiranti e consente di ottenere il miglior equilibrio tra silenzio, potenza ed efficienza energetica.

Now, thanks to Airmatic, your extraction hob area is completely automatic. The smart sensor can distinguish between the quality of the fumes and type of cooking and combine this information with the number and power of the induction hob areas being used. Even when the hob is switched off, the system automatically adapts by gradually decreasing extraction and eliminating any residual fumes and odours. This advanced technology is top of the range in the world of extractor hobs and allows you to obtain the best balance between silence, power and energy efficiency.

**AUTOCAPTURE**

Con Autocapture non dovrai preoccuparti di regolare l'aspirazione in base alle cotture avviate, ma sarà la cappa stessa a indentificare le zone cottura attive e impostare di conseguenza la potenza, tenendo in considerazione il miglior equilibrio tra silenzio, potenza ed efficienza energetica. E a cottura ultimata, il sistema diminuisce gradualmente la velocità, in modo da eliminare i vapori e gli odori residui. Il piano cottura aspirante diventa ancora più funzionale e pratico, per cotture perfette e aspirazione ottimale.

With Autocapture, you will not have to worry about adjusting extraction based on what you are cooking. The hood will identify the cooking areas that are active and set the power accordingly, finding the best balance between silence, power and energy efficiency. And when you have finished cooking, the system gradually decreases the speed, eliminating any residual fumes and odours. The extraction hob becomes even more functional and practical for perfect cooking and excellent extraction.







## PURIFICAZIONE DELL'ARIA / AIR PURIFICATION

## ELICA AIR PURE

**MULTIFUNCTION**

Ikona Maxxi Pure incorpora in un unico prodotto una cappa e un purificatore d'aria. Il prodotto è stato sapientemente progettato per separare il modulo cappa dal purificatore d'aria senza alcun compromesso in termini di prestazioni e fruibilità e per farli funzionare il modo efficace ed indipendente. Un prodotto "2 in 1" progettato per migliorare la qualità dell'aria, senza la necessità di dispositivi aggiuntivi o sistemi di monitoraggio complessi, spesso ingombranti e antiestetici.

Ikona Maxxi Pure incorporates a hood and air purifier in a single product. The product has been cleverly designed to separate the hood module from the air purifier without compromising on performance and usability, and to make them work efficiently and independently. A "2 in 1" product designed to improve the air quality without the need for additional devices or complex monitoring systems, often invasive and disagreeable.

**PURE SILENCE**

La purificazione dell'aria è estremamente discreta, in modalità Silent il livello sonoro di 33 dBA è impercettibile, paragonabile al livello sonoro di una biblioteca. Il sistema Elica funziona senza alcun inquinamento acustico, creando un ambiente confortevole nella tua cucina-living.

The air purification is extremely discreet, in Silent mode the sound level of 33 dBA is imperceptible, comparable to the sound level of a library. The Elica system works without any noise pollution, creating a comfortable environment in your kitchen-living area.

**COMBO PURE FILTER**

Il purificatore d'aria, dotato di una speciale combinazione di HEPA e filtro al carbone, cattura particelle fino a 1 micron, liberando il tuo spazio da odori, allergeni come polvere, peli di animali, pollini, muffe, inquinanti prodotti da prodotti per la pulizia della casa, pitture e rivestimenti.

The air purifier, fitted with a special combined HEPA and carbon filter, captures particles as small as 1 micron, freeing the space of unpleasant odours, allergens such as dust, animal hair, pollen, mould, pollutants produced by household cleaning agents, paints and coverings.

## COTTURA / COOKING



### MULTI FLEXI SPACE

Tante pentole grandi sul fuoco insieme? Con il sistema Multi Flexi Space puoi contare su un maggiore spazio in lunghezza e in larghezza per i tuoi tegami. Puoi far scivolare le padelle da un fuoco all'altro senza sollevarle, grazie alle griglie a croce chiusa che ricreano una superficie piatta e continua. Un pratico piano di appoggio in ghisa consente di avere sempre a portata di mano tutto quello di cui hai bisogno.

Lots of large pans on the stove together? With the Multi Flexi Space system, you have more space available both in length and width when using large pots. You can slide the pans from one ring to another without lifting them thanks to the closed cross grids which create a flat, continuous surface. A practical cast iron worktop ensures that everything you need is always at hand.



### DUAL BURNER

Con Dual Burner che la tua pentola sia mini o maxi non sarà più un problema. L'innovativo bruciatore è dotato di due corone concentriche indipendenti tra loro, risultando così perfetto sia per una piccola moka che per un ampio tegame.

With Dual Burner, having small or large pans is not a problem. The innovative burner features a double crown with independent ignition of both burners, so perfect for both a small mocha coffee and a big pan.



### BRIDGE ZONE

Quando si cucina utilizzando pentole allungate o di grande dimensioni, il rischio è che si disperda progressivamente il calore sulla superficie della teglia, dal centro verso l'esterno. La funzione Bridge Zone risolve il problema, collegando due aree di cottura in un'unica zona dalle dimensioni più grandi. Stesso livello di potenza, temperatura uniforme e costante per la migliore resa dei tuoi piatti.

When you cook using longer or large pans, there is a risk that the heat is progressively dispersed on the surface of the pan from the centre outwards. The Bridge Zone function solves the problem by joining two cooking areas into one single larger area. With the same power, uniform and constant temperature for the best result of your dishes.



### TEMPERATURE MANAGER

Nella nostra quotidianità realizziamo spesso ricette che caratterizzano la nostra cucina e che prevedono tipologie di cottura standard. La funzione Temperature Manager è un'alleata preziosa per ottimizzare i tempi: sarà sufficiente avviare uno dei 3 programmi preimpostati (42,72, 92 gradi) con un semplice e intuitivo tasto e avviare la cottura dei tuoi piatti più delicati, come salse o mousse, riscaldare piatti già pronti, o bollire l'acqua. Nessuno spreco di tempo e massima resa.

On a daily basis, we often prepare our own signature recipes as well as standard dishes. The Temperature Manager function is an excellent tool for optimising times. Just start one of the three pre-set programs (42, 72 or 92 degrees) with a simple, intuitive button and start cooking your more delicate dishes, such as mousses or sauces, reheating dishes or boiling water. No wasting of time and maximum efficiency.



## COTTURA / COOKING

**KEEP WARM**

Per chi prepara pranzo e cena in un'unica volta, per chi trova invece il piatto già pronto solo da riscaldare o per chi ha un imprevisto e ritarda il rientro a casa, Elica propone la pratica funzione Keep Warm, che mantiene in caldo le pietanze appena cucinate. È possibile attivare Keep Warm su ogni zona di cottura.

If you make lunch and dinner in one go, if you just need to reheat a dish or if an unexpected event means you are late getting home, Elica offers the practical Keep Warm function which keeps dishes that have just been cooked warm. The Keep Warm function can be enabled for any cooking area.

**TIMER**

Dimenticati del tempo di cottura dei piatti attivando il timer. Basterà impostare i minuti e far partire il countdown, al termine si spegnerà automaticamente la zona cottura e si attiverà un segnale acustico. È possibile impostare timer indipendenti su più zone contemporaneamente tramite il telecomando touch.

Forget about cooking times by turning on the timer. Just set the minutes and start the countdown. At the end, the cooking area will be automatically switched off and a beeper will sound. You can set independent timers on more than one area at the same time with the touch remote control.

**POWER LIMITATION**

Con Power Limitation imposti, in fase di installazione, il limite di potenza massima assorbita dal prodotto, assicurandoti così di non superare mai la soglia preimpostata. Cucinare al meglio senza interruzioni e in totale sicurezza.

If Power Limitation is set during installation, the maximum power absorbed by the product is limited, thus ensuring that you never exceed the pre-set limit. So you can cook efficiently with no interruptions in total safety.

**STOP & GO**

Capita a volte che ci si debba allontanare improvvisamente dalla cucina proprio nel bel mezzo della preparazione di una ricetta, interrompendo la cottura dei cibi. In questo caso attivando la funzione Stop&Go si spengono tutte le zone attive in un unico gesto, salvaguardando le ricette in corso.

Sometimes you need to unexpectedly leave the kitchen in the middle of preparing a recipe, interrupting the cooking. In this case, if you enable the Stop&Go function, all the active areas can be switched off with a single gesture, saving whatever is being cooked.

**PAUSE**

Con Pause&Recall potrai spegnere in un solo gesto tutte le zone cottura in funzione, per poi riattivarle con un semplice tasto alla stessa potenza precedentemente impostata, coniugando sicurezza, risultato di cottura e gestione multi-tasking.

With Pause&Recall, you can switch off all the cooking areas with one single gesture and then, restart them with a simple press of a button at the same previously set power, combining safety, cooking result and multi-tasking management.

**POT DETECTOR**

Sulla superficie del piano a induzione non sempre è facile individuare dove posizionare la pentola. Con la funzione Pot Detector il piano rileva automaticamente la presenza del tegame sulla zona di cottura e eroga la potenza solo in presenza di pentole posizionate correttamente.

It is easy to see where to position the pot on the induction hob. With Pot Detector, the hob automatically detects the presence of the pot on the cooking area and provides heat only when it is correctly positioned.

**CHILD LOCK**

Per chi ha bambini in casa la funzione Child Lock è preziosa per evitare accensioni accidentali delle zone cottura o dell'aspirazione. La funzione può essere attivata a prodotto acceso, ma con le aree cottura e l'aspirazione spente.

If you have children in your home, the Child Lock function is invaluable for ensuring the cooking or extraction areas are not accidentally switched on. The function can be enabled when the product is switched on but the cooking areas and extraction are switched off.

ELICA CONNECT



## LA GAMMA ELICA CONNECT, PENSATA PER FACILITARTI LA VITA THE ELICA CONNECT RANGE, DESIGNED TO MAKE LIFE EASIER

Elica ti è vicina nella tua vita di tutti i giorni ed ha creato una gamma di prodotti connessi, controllabili dallo smartphone o tramite l'assistente vocale, che si sposano al meglio con lo stile della tua cucina, grazie al loro design innovativo. Soluzioni tecniche all'avanguardia sono state studiate per semplificare le attività quotidiane, quelle con cui ti prendi cura di te e della tua famiglia ma che ti portano via tempo ed energie. Se vuoi proteggere l'aria della tua casa, Elica Connect lo fa per te e tu puoi pensare solo a goderti il tuo tempo libero, in pieno relax e senza nessuna preoccupazione.

Elica is at your service in your everyday life and has created a range of connected products controlled by smartphone or via the vocal assistant which fit in seamlessly with the style of your kitchen, thanks to their innovative design. Avant-garde technical solutions have been developed to simplify everyday tasks, the ones with which you take care of yourself and your family, but take up your time and energy. If want to protect the air in your home, Elica Connect does it for you and you can concentrate on enjoying your free time, in total relaxation, with no worries.

### Tutto a portata di click All just one click away

Elica Connect è un'applicazione semplice e intuitiva, scaricabile in pochi secondi. Dopo aver registrato il prodotto nella app, ricevi l'accesso ad un mondo di servizi ideati per rendere il tuo quotidiano più semplice, in casa, distante da casa e ovunque tu sia. Dalla visualizzazione dello stato dei filtri al funzionamento a distanza della tua cappa, fino alla guida alla manutenzione e altro ancora.

Elica Connect is a simple and intuitive application that can be downloaded in a matter of seconds. After registering the product on the app, you will be granted access to a world of services designed to make your daily routine easier, at home, far away from home or wherever you are. From viewing the filter status to the remote operation of your hood, as well as the guide to maintenance and much more.



### Cosa puoi chiedere al tuo assistente vocale What you can ask your vocal assistant

Il tuo assistente vocale ti permette di accendere e spegnere l'aspirazione della tua cappa, selezionando la velocità preferita. Può anche regolare l'intensità e la tonalità della luce. Seguendo le tue indicazioni, setterà l'illuminazione in base all'atmosfera che vuoi creare, intima e rilassante oppure quella adatta ad un banco cucina dove ogni dettaglio deve essere ben visibile.

Your vocal assistant allows you to switch the hood extraction on and off and to select the preferred speed. You can also adjust the intensity and tone of the light. Following your instructions, it will set the lighting based on the atmosphere you want to create; intimate and relaxing or adapted to a kitchen workbench where every detail must be clearly visible.

## Cosa puoi fare con la App Elica Connect What you can do with the Elica Connect app

### IMPOSTARE LE LUCI    CONFIGURE THE LIGHTS

Si può regolare l'intensità e la potenza della luce della cappa in pochi secondi, modulare la temperatura dei led, da luce calda a luce fredda, allineando l'illuminazione della cappa a quella dell'ambiente, per creare un'atmosfera uniforme in tutta la stanza.

You can adjust the intensity and power of the hood lights in just a few seconds, modulate the temperature of the LEDs from warm to cold light, aligning the lighting of the hood with that of the room to create a uniform atmosphere throughout.

### REGOLARE L'ASPIRAZIONE    ADJUST EXTRACTION

Oltre all'accensione e allo spegnimento del sistema di aspirazione, a seconda delle esigenze, è possibile regolare la potenza di aspirazione della cappa, anche a distanza. Grazie alla Funzione Timer, la tua cappa si spegne quando lo decidi tu. Si possono usare le regolazioni di default, oppure personalizzare il funzionamento del timer. Inoltre, selezionando la funzione Silent potrai assicurarti un'ottima performance in termini di aspirazione e silenziosità. Chiacchera con gli amici o goditi la TV mentre prepari il tuo prossimo piatto.

In addition to switching the extraction system on and off based on your requirements, it is possible to adjust the extraction power of the hood, even remotely. Your hood switches off when you decide thanks to the timer function. You can use the default adjustments or customise the timer functions. You can ensure excellent performance in terms of extraction and noise levels by selecting the Silent function. Chat with your friends or watch TV while you are preparing your next dish.

### PRENDERTI CURA DEI FILTRI    TAKE CARE OF THE FILTERS

Se l'efficienza dei tuoi filtri scende sotto la soglia minima, una notifica ti avvertirà che è necessario pulire, sostituire o rigenerare i filtri della tua cappa, per garantirti le migliori prestazioni e un'aria sempre pulita in casa. La sezione "How to" ti illustra passo dopo passo come estrarre, mantenere e reinserire i filtri della tua cappa, inclusi i passaggi per la pulizia degli stessi. Se il tuo filtro è da sostituire, la app ti porta direttamente alla sezione Elica Shop, dove trovi tutti i filtri compatibili con il modello della tua cappa. Da qui, basta un click per acquistare e ricevere comodamente a casa il filtro, l'accessorio o i prodotti di pulizia eco-friendly.

If the efficiency of your filters falls below the minimum threshold, an alert will notify you that it is necessary to clean, replace or regenerate the filters in your hood to guarantee the best performance and clean air in your home. The "How to" section provides you with a step by step guide on how to remove, maintain and reinsert the filters in your hood, including the steps on how to clean them. If your filter needs replacing, the app will take you directly to the Elica Shop where you can find all the filters that are compatible with your hood model. From here, with just one click, you can purchase and conveniently receive the filter, accessory or eco-friendly cleaning products in your home.

### RICEVERE ASSISTENZA    RECEIVE SUPPORT

Contattarci è più facile e veloce con la App Elica Connect. L'assistenza Elica sarà subito pronta a risolvere il problema dandoti suggerimenti chiari su come procedere. Inoltre, puoi dimenticarti dei documenti cartacei: all'interno della App Elica Connect, trovi tutto ciò di cui hai bisogno dalla Garanzia al Libretto d'uso e manutenzione. Puoi consultarli quando vuoi senza perdere un secondo del tuo tempo.

Contacting us is easier and faster with the Elica Connect App. Elica support will be instantly on hand to solve the problem by giving you clear suggestions on how to proceed. You can also forget about paper documents because everything you need is in the Elica Connect App, from the warranty to the use and maintenance booklet. You can consult it whenever you want to without losing a second of your time.





TESLA AS

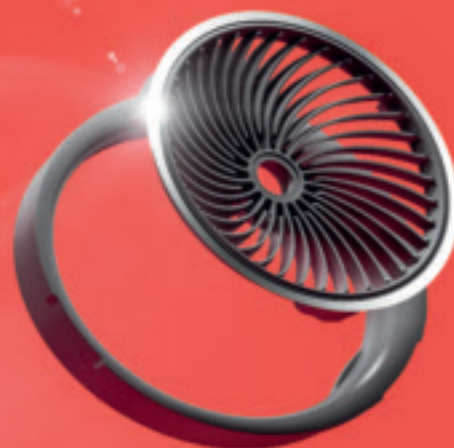

# NIKOLATESLA

Cottura e aspirazione, solidità e stile diventano gli elementi complementari che danno vita a un prodotto unico. La prospettiva scomposta mette in luce i ricercati materiali caratterizzanti la gamma NikolaTesla: le griglie in ghisa e il vetro nero, accostati in un design ricercato e lineare. Il risultato è un'unica visione d'insieme da cui nasce un prodotto dove tecnologia e innovazione, design ed eleganza si esprimono in un perfetto equilibrio. L'intuitivo cambio di prospettiva porta l'aspirazione in basso, conferendo al prodotto una componente innovativa di grande valore.

Cooking and extraction, dependability and style are the added elements that create a unique product. The broken-up view highlights the refined materials that characterise the NikolaTesla range: the cast iron grilles and black glass, combined in a refined and linear design. The result is a unique overall vision for a product where technology and innovation, design and elegance are showcased in perfect harmony. The intuitive change of perspective features downward extraction, resulting in a highly-innovative product.

ASPIRATION SYSTEM



## Perchè scegliere un NikolaTesla Why choose a NikolaTesla

### Armonia e semplicità Harmony and simplicity



La passione per la cucina si esprime oggi attraverso una precisa progettazione dell'ambiente e un'attenta scelta dei suoi complementi. I piani cottura aspiranti sono la risposta a chi predilige una progettualità che favorisce linee pulite e spazi aperti, in cui i volumi verticali spariscono, per consentire una visione d'insieme fluida.

Secondo recenti ricerche di mercato, scegliamo sempre più spesso di unire living e cucina per preparare pranzi e cene in un ambiente conviviale, che non ci isoli dal resto della casa. Per farlo ricerchiamo elettrodomestici in grado di semplificare la vita, che ci garantiscano la massima funzionalità durante la preparazione dei cibi e che spariscono discreti una volta spenti, grazie a un'estetica curata, in armonia con lo spazio circostante.



A love of cooking is now expressed through an accurate design of the kitchen space and a careful choice of accessories. Extractor hobs are the solution for anyone who prefers a design with clean lines and open spaces where vertical volumes disappear, making way for an overall streamlined look.

According to recent market research, we are opting more and more to join the living room and kitchen areas, so we can prepare lunches and dinners in a social setting that does not cut us off from the rest of the house. To achieve this, we seek out electrical appliances which make our lives easier and guarantee maximum functionality when preparing food; appliances that discretely disappear once turned off thanks to their attractive exterior design which blends seamlessly into the background.





## Eclettico e completo Eclectic and complete

La gamma di piani cottura con aspirazione integrata NikolaTesla è la risposta di Elica alle esigenze di stile, performance e semplicità di utilizzo. Ma non solo. NikolaTesla è la soluzione per chi, anche in cucina, sceglie l'emozione. L'emozione di essere stupito. L'emozione di superarsi in ambiziose ricette, senza preoccuparsi degli odori. La serenità di poter installare e utilizzare il prodotto con la massima semplicità. La sorpresa di riuscire a pulirlo facilmente e velocemente. La gioia di vivere ogni giorno un piano aspirante che sembra disegnato esattamente per la nostra casa. Un cuore tecnologico avanzato, a servizio delle migliori performance di aspirazione e cottura, prende vita in un prodotto dal design ricercato, realizzato con materiali durevoli, in cui le finiture sono state studiate nel dettaglio.

La gamma NikolaTesla si declina in modelli unici, adatti a ogni necessità: il design pulito di Switch, l'integrazione della bilancia nel Libra, l'utilizzo del gas nel Flame e le dimensioni ridotte a 60 o 70 cm del Fit si aggiungono ai modelli Prime e One, Compasso d'Oro, in una linea eclettica e completa.



The NikolaTesla range of integrated extractor hobs is Elica's answer to demand for style, performance and ease of use. But it doesn't stop there. NikolaTesla is the solution for anyone whose aim is to conjure up an emotion in the kitchen as well. The emotion of being amazed. The emotion of outdoing yourself with ambitious recipes and not having to worry about the fumes. The peace of mind of being to install and use the product with the greatest of ease. The pleasant surprise of being able to clean it quickly and easily. The enjoyment of using an extraction hob every day that seems to have been tailor-made for your home. An avant-garde inner technological unit, designed to provide the best extraction and cooking performance, is showcased in a sophisticated designer product, manufactured from hard-wearing materials with carefully crafted finishes. The NikolaTesla range consists of unique models, suitable for any requirement: the clean design of Switch; the integration of the scales in Libra and the use of gas in Flame, while the compact 60- or 70-cm size of Fit is added to the Prime, One and Compasso d'Oro models to produce an eclectic and complete range.

## FUNZIONAMENTO E PRINCIPALI PLUS OPERATION AND MAIN ADVANTAGES

La qualità dell'aria è da sempre alla base dell'offerta di elica, che ha portato anche nei piani cottura le migliori tecnologie per una aspirazione dal basso intelligente e performante di fumi e odori.

Quality of air has always been key to Elica's products, incorporating the very best technology in hobs for intelligent, high-performance, downdraft extraction of fumes and of odours.

### MIGLIORE VELOCITÀ DI ASPIRAZIONE

#### BEST EXTRACTION SPEED

Tutti i modelli NikolaTesla hanno una velocità di aspirazione di 5,1 m/s, e riescono a catturare tutti i fumi e gli odori prima che salgano verso l'alto. Questa caratteristica li rende prodotti unici nel loro genere per efficacia e prestazioni.

All the NikolaTesla models provide a very powerful extraction speed of 5.1 m/s. They can capture all the fumes and odours before they start to rise. This feature makes these products unique in terms of efficiency and performance.



### PIÙ SPAZIO PER I TUOI CASSETTI

#### MORE SPACE FOR DRAWERS

Il design del prodotto è stato studiato per ottimizzare gli spazi interni del cabinet. La tubazione posteriore mobile e posizionabile a ridosso dello schienale del mobile, consente l'utilizzo di cassetti più profondi e spaziosi. Il risultato è una maggiore superficie libera dall'ingombro del piano, da poter sfruttare per la conservazione di cibi o utensili da cucina.

The product design has been studied to optimise the internal spaces of the cabinet. The adjustable and positionable rear pipe, which sits flush to the back of the cabinet, makes room for deeper and more spacious drawers. The result is greater a surface area, unobstructed by the worktop, which can be used to store food or kitchen utensils.

### SENSORI INTELLIGENTI E NON CI PENSI PIÙ

#### SMART SENSORS AND THAT'S ALL YOU NEED TO KNOW

L'innovativa funzione Airmatic prevede l'utilizzo di sensori intelligenti, che permettono di distinguere la quantità e la qualità dei fumi prodotti e impostare la potenza di aspirazione più indicata.

The innovative Airmatic function involves the use of smart sensors which are able to detect the quantity and quality of the fumes produced and to set the most suitable extraction power accordingly.

### AUTOREGOLAZIONE DELL'ASPIRAZIONE

#### SELF-ADJUSTING EXTRACTION

Con Autocapture possiamo rimanere concentrati solo sulla nostra ricetta: sarà la cappa ad autoregolarsi in base al numero e alla potenza delle zone cottura impegnate.

With Autocapture, you can concentrate on your recipe and leave the hood to automatically adjust based on the number and power of the hobs being used.



**PULIZIA FACILE E VELOCE**  
FAST AND EASY TO CLEAN

La superficie liscia e continua di NikolaTesla è uno degli elementi innovativi della nuova generazione di piani aspiranti Elica. Il vetro ceramico, privo di interruzioni, si rivela un dettaglio di design efficace anche nel rendere veloce la pulizia.

The smooth, seamless surface of NikolaTesla is one of the innovative features of the new generation of Elica extraction hobs. The seamless ceramic glass is an efficient design detail that also makes short work of cleaning.

**MANUTENZIONE PRATICA**  
PRACTICAL MAINTENANCE

La bellezza si coniuga alla praticità anche nelle operazioni di manutenzione: il sistema brevettato da Elica permette la rimozione dei filtri dall'alto e, grazie all'apertura nel vetro che si mimetizza con l'estetica, si può lavare in totale sicurezza il vano interno.

Beauty is combined with practicality when it comes to maintenance as well. The system, patented by Elica, allows the filters to be removed from above while the internal compartment can be washed in total safety, thanks to the opening in the glass that blends in with the aesthetics.



**INTERFACCIA INTUITIVA E USER FRIENDLY**  
INTUITIVE AND USER-FRIENDLY INTERFACE

Per vivere ogni giorno il piacere di cucinare, i piani aspiranti Elica sono dotati di un'interfaccia semplice e intuitiva. Il pannello comandi touch control permette di controllare separatamente zone cottura e cappa e, in modalità standby, diventa totalmente invisibile. Regolare la cottura non è stato mai così facile e confortevole.

Elica extractor hobs feature a simple and intuitive interface to allow you to enjoy the pleasure of cooking every day. The touch control panel allows the cooking areas and hood to be controlled separately and, in standby mode, it becomes totally invisible. Controlling cooking has never been so easy and convenient.

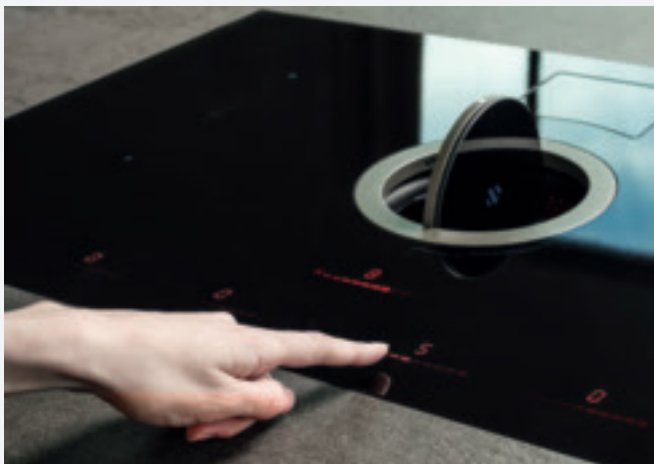

**MIGLIORE CAPACITÀ DI FILTRAGGIO ODORI**  
IMPROVED ODOUR FILTERING CAPABILITY

Ecco perché la gamma NikolaTesla, nella versione filtrante, prevede un filtro ad alta capacità di depurazione degli odori, in grado di raggiungere soglie di filtraggio maggiori dell'82% contro una media del mercato del 60%. E per garantire la massima facilità di manutenzione, è rigenerabile fino a 3 anni.

This is why the NikolaTesla range, in the filtering version, features a filter with a high odour purification capacity, capable of reaching filtering thresholds over 82% compared to a market average of 60%. And to guarantee extremely easy maintenance, the filter can be regenerated for up to 3 years.

NikolaTesla è stato ideato per adattarsi a molteplici tipologie di cucina. Nella versione filtrante standard NikolaTesla è dotato di tutto l'occorrente per essere installato, incluso l'esclusivo profilo cromato che rifinisce il taglio dello zoccolo necessario per l'uscita dell'aria. Nella versione aspirante le tubazioni sono accessori e l'utente potrà scegliere la configurazione ideale in base alle proprie esigenze architettoniche. È possibile installare NikolaTesla in appoggio diretto sul piano di lavoro (standard) o inserito in un'alloggiamento senza discontinuità con il top (filotop).

NikolaTesla has been designed to fit into many different types of kitchens. In the standard filtering version, NikolaTesla is equipped with every component needed for installation, including the exclusive chrome-plated profile that finishes the air outlet hole at baseboard. In the aspiration version, pipes are supplied as accessories and users can choose the best configuration, based on the architecture of their home. It is possible to install NikolaTesla directly against the countertop (standard) or inserted in a slot, blending in with the countertop. (Filotop).

## NIKOLATESLA LIBRA / ONE / PRIME / SWITCH

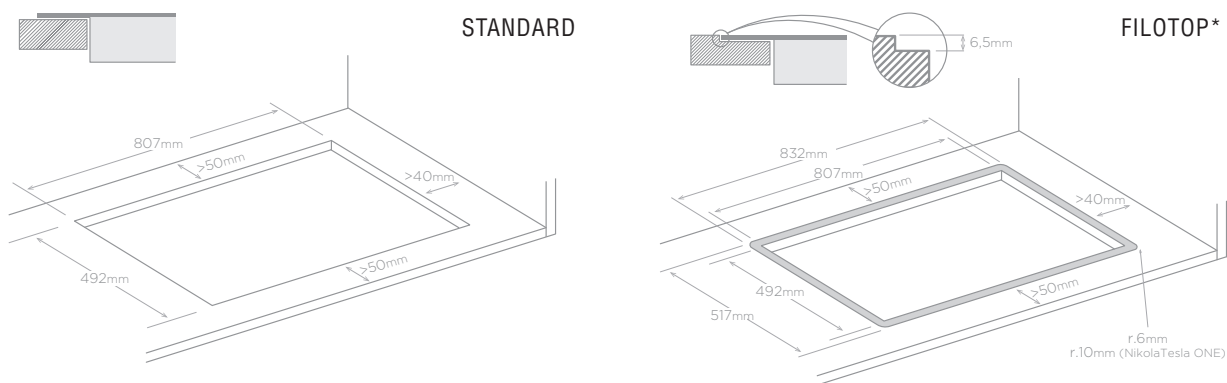

## NIKOLATESLA FLAME

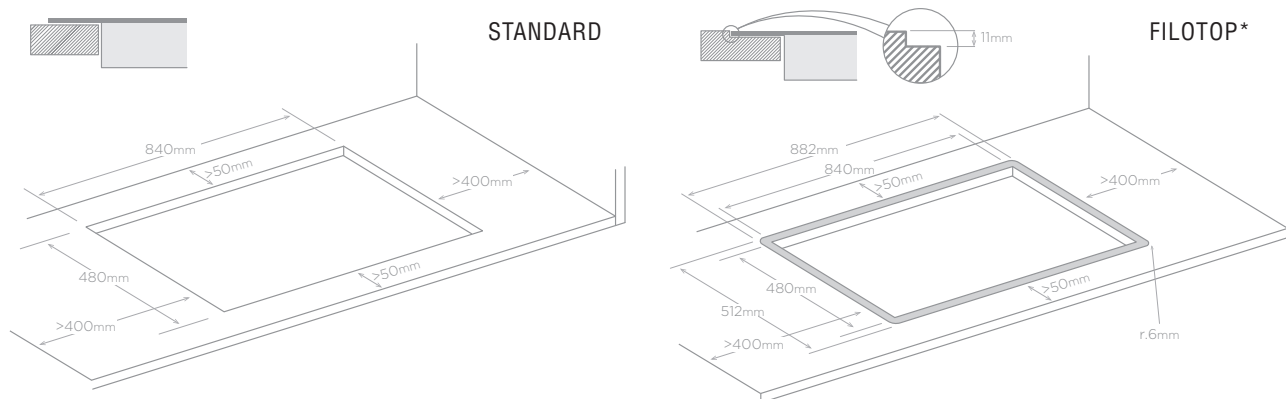

\* Dimensioni consigliate filotop: per tolleranze differenti, attenersi alla reale dimensione del vetro.

\* Recommended filotop dimensions: for different tolerances, respect the actual dimensions of the glass.

PER ULTERIORI APPROFONDIMENTI CONSULTARE IL MANUALE DI INSTALLAZIONE DEL PRODOTTO.  
FOR FURTHER INFORMATION, CONSULT THE PRODUCT INSTALLATION MANUAL.

## NELLA SCATOLA

Nikolatesla è fornito già completo per essere installato (nelle versioni standard) sia in aspirante che in filtrante. Di seguito sono riportate le configurazioni consentite con i componenti a corredo nell'imballo. Per altre esigenze di montaggio sono a disposizione, come accessori, curve e tubazioni.

## IN THE BOX

NikolaTesla includes everything it needs (in the standard version) for being installed in both aspiration and filtering version. Possible configurations, and related components included in the packaging, are mentioned below. For any other installation needs, bends and pipes are available as accessories.

NIKOLATESLA VERSIONE  
ASPIRANTE STANDARD  
NikolaTesla standard  
Duct-out mode



NIKOLATESLA VERSIONI  
FILTRANTI STANDARD  
NikolaTesla standard  
Filtering modes



Con le tubazioni accessorie a disposizione potrai costruire la configurazione di Nikolatesla più adatta alle tue esigenze.

Thanks to the selection of accessory pipe fittings, your Nikolatesla can be configured in the way that best suits your needs.

## NIKOLATESLA VERSIONE FILTRANTE FILTERING MODE \*



## NIKOLATESLA VERSIONE ASPIRANTE DUCT-OUT MODE \*



\* Tutte le immagini sono esempi di installazione  
All images are samples installation



Aperto il coperchio si ha la possibilità di rimuovere le tre batterie di filtro ceramico (rigenerabile) ad altissime prestazioni e di svuotare il vano di sicurezza raccolta liquidi, l'unico in grado di proteggere il motore in caso di fuoriuscita di liquidi derivanti dalla cottura.

By opening the cove, you can remove the three batteries of the high performance ceramic filter (regenerable) and empty the liquid collection safety compartment, which is the only component that can protect the motor in case of leakage of cooking liquids.

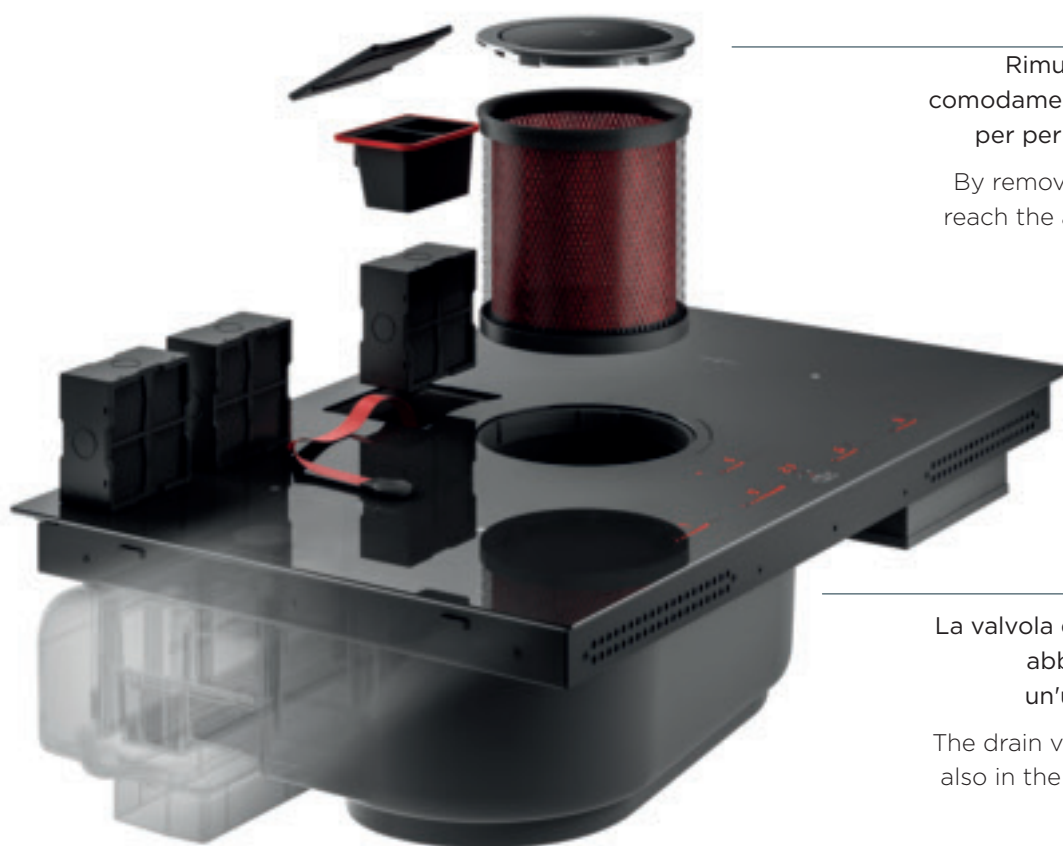

Rimuovendo la griglia si accede comodamente al filtro grassi alluminio per permetterne una facile pulizia.

By removing the grid, you can easily reach the aluminum grease filter thus performing easy cleaning.

La valvola di scarico per la fuoriuscita abbondante di liquidi assicura un'ulteriore sicurezza igienica.

The drain valve guarantees cleanliness also in the case of abundant overflow of liquids.



NikolaTesla è stato pensato per garantire la massima flessibilità di installazione per l'ottimizzazione degli spazi interni del cabinet grazie a una tubazione posteriore movibile e posizionabile sempre a ridosso dello schienale per consentire l'utilizzo di cassette più profonde e spaziosi.

NikolaTesla has been conceived to guarantee maximum installation flexibility, in order to best use the cabinet internal spaces, thanks to a movable rear piping, which can be positioned close to the back, allowing for the use of deeper and more spacious drawers.

**NIKOLATESLA VERSIONE ASPIRANTE STANDARD**

NikolaTesla standard Duct-out mode

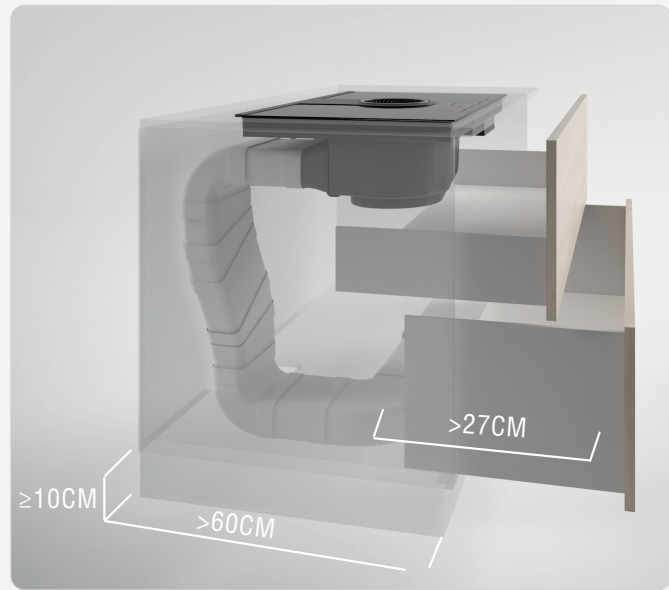
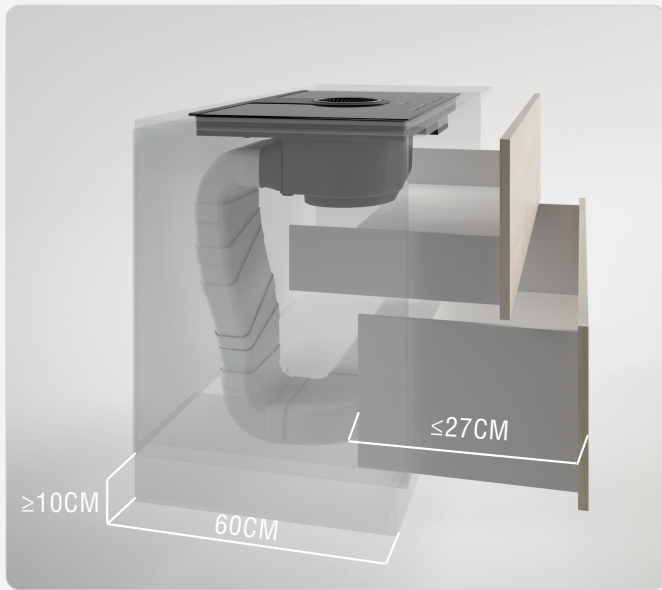

**NIKOLATESLA VERSIONI FILTRANTI STANDARD**

NikolaTesla standard filtering modes

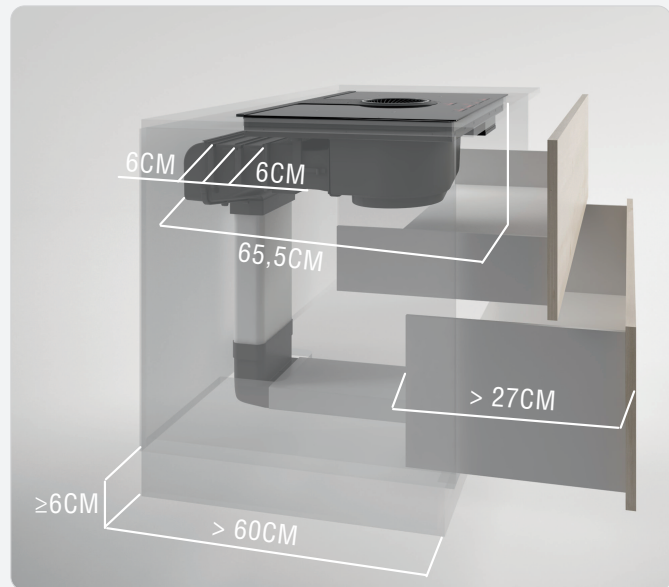
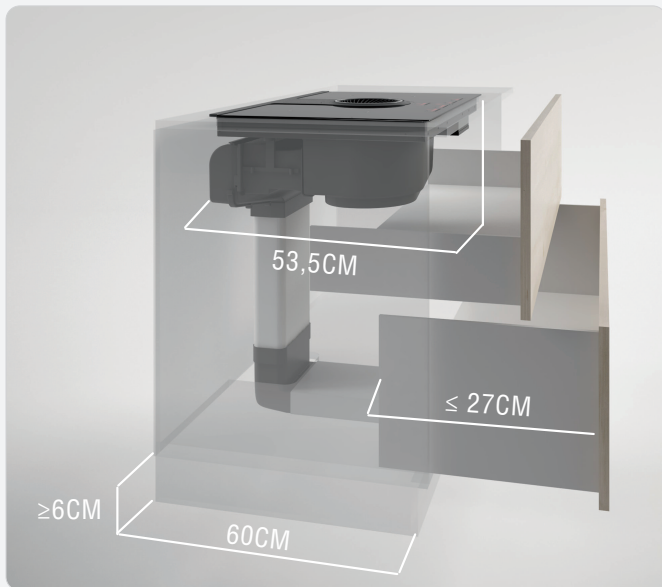



# NIKOLATESLA SWITCH

DESIGN FABRIZIO CRISÀ





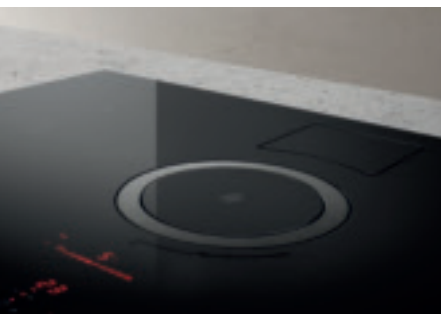



# NIKOLATESLA SWITCH

DESIGN FABRIZIO CRISÀ

83x51x21 cm  
80,7x49,2 cm (cut)  
Aspirante/Filtrante Duct-out/Filtering  
Vetro nero, vetro bianco "ICE GREY"  
Black glass, white glass "ICE GREY"



L'elemento estetico centrale, in vetro nero ed alluminio effetto ghisa o vetro bianco e acciaio, nasconde il cuore aspirante che può essere attivato con un semplice gesto anche in modalità completamente automatica, possibile grazie ai sensori intelligenti di cui il prodotto è dotato.

L'interfaccia del prodotto Direct Slider permette di azionare le varie zone di cottura e aspirazione in modo semplice ed intuitivo.

The central aesthetic element in black glass and cast iron-look aluminium or white glass and steel, conceals the heart of the extraction unit which can be activated with a simple touch even in fully automatic mode, thanks to the integrated smart sensors.

The Direct Slider interface allows the various cooking and extraction areas to be controlled simply and intuitively.

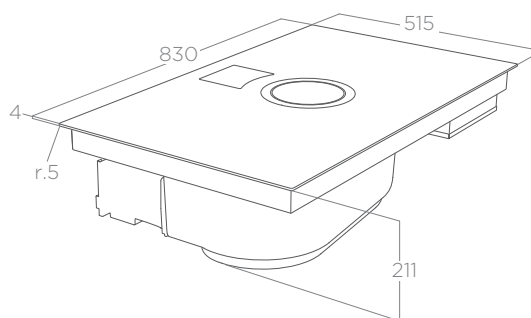
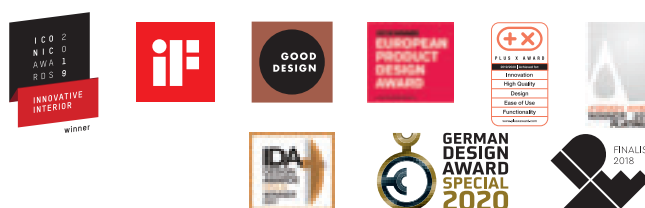

## ASPIRAZIONE ASPIRATION

	ASPIRANTE DUCT-OUT	FILTRANTE FILTERING
Comandi Controls	Touch control slider 8V+2I 8S+2B slider touch control	Touch control slider 8V+2I 8S+2B slider touch control
Portata intensiva Booster airflow	630 m <sup>3</sup> /h	550 m <sup>3</sup> /h
Velocità di aspirazione Suction speed	5,1 m/s	5,1 m/s
Livello sonoro min-max Noise level min-max	33 - 59 db(A)	39 - 64 db(A)
Assorbimento totale Total absorption	175 W	175 W

## COTTURA COOKING

Comandi Controls	Touch control direct slider 9P+I 9P+B slider touch control direct
Assorbimento Absorption	7,2 kW
Power limitation	3,1 - 4,5 kW
Voltaggio Voltage	220 - 240 V
Zone cottura Cooking zones (Misura-Potenza Size-Power)	1 210x190 mm - 2,1/3 kW 2 210x190 mm - 2,1/3 kW 3 210x190 mm - 2,1/3 kW 4 210x190 mm - 2,1/3 kW
Zone Bridge Bridge zone	2

## FUNZIONI FUNCTIONS

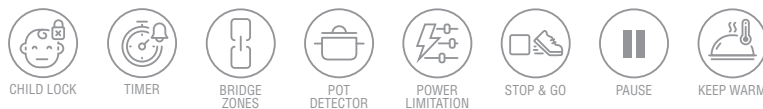

## MODELLI MODELS

NIKOLATESLA SWITCH BL/A/83	PRF0146212A	3.139,00 €
NIKOLATESLA SWITCH BL/F/83 (*)	PRF0146210A	3.355,00 €
NIKOLATESLA SWITCH WH/A/83	PRF0146216A	3.139,00 €
NIKOLATESLA SWITCH WH/F/83 (*)	PRF0146213A	3.355,00 €

(\*) Modello non soggetto a certificazione energetica obbligatoria.  
(\*) Model not subject to compulsory energy certification.

Filtro grassi alluminio incluso Grease aluminium Filter included  
Filtro in ceramica anti-odori incluso (\*) Ceramic odour filter included (\*)



LONG LIFE  
FILTER ++



COMFORT  
SILENCE



EASY TO  
MAINTAIN



AIRMATIC



222x89 mm



ENERGY  
CLASS  
(A+/+/D)

## ACCESSORI ACCESSORIES

Filtro in ceramica anti-odori Ceramic odour filter	KIT0120952A	342,00 €
---	-------------	----------





# NIKOLATESLA ONE

DESIGN FABRIZIO CRISÀ





# NIKOLATESLA ONE

DESIGN FABRIZIO CRISÀ

83x51x 21 cm  
80,7x49,2 cm (cut)  
Aspirante/Filtrante Duct-out/Filtering  
Vetro nero  
Black glass



Il prodotto, vincitore del XXV Compasso D'oro ADI, combina la tecnologia più avanzata per la cattura di vapori ed odori dal basso all'eccellenza del design distintivo Elica.

L'interfaccia del prodotto Direct Slider permette di azionare le varie zone di cottura e aspirazione in modo semplice ed intuitivo.

The product, winner of the 25th ADI Compasso d'Oro award, combines cutting-edge downdraft technology, to capture vapours and odours, with Elica's signature state-of-the-art design.

The Direct Slider interface allows the various cooking and extraction areas to be controlled simply and intuitively.



reddot award 2017  
winner



INTERIOR  
INNOVATION  
winner

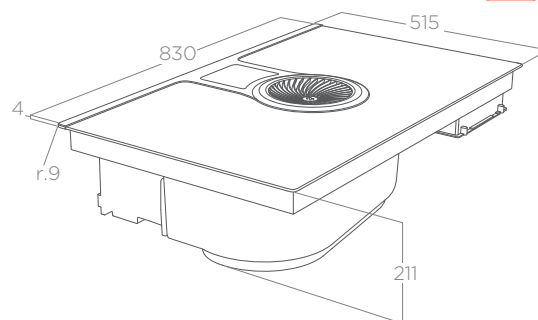

## ASPIRAZIONE ASPIRATION

	ASPIRANTE DUCT-OUT	FILTRANTE FILTERING
Comandi ONE HP	Touch control slider 9V+I	Touch control slider 9V+I
Controls ONE HP	9S+B slider touch control	9S+B slider touch control
Comandi ONE	Touch control 9V+I	Touch control 9V+I
Controls ONE	9S+B touch control	9S+B touch control
Portata intensiva	640 m <sup>3</sup> /h	545 m <sup>3</sup> /h
Booster airflow		
Velocità di aspirazione	5,1 m/s	5,1 m/s
Suction speed		
Livello sonoro min-max	34 - 61 db(A)	40 - 67 db(A)
Noise level min-max		
Assorbimento totale	175 W	175 W
Total absorption		

Filtro grassi alluminio incluso Grease aluminium Filter included

Filtro in ceramica anti-odori incluso (\*) Ceramic odour filter included (\*)



LONG LIFE  
FILTER ++



COMFORT  
SILENCE



EASY TO  
MAINTAIN



AUTO  
CAPTURE



222x89 mm



ENERGY  
CLASS  
(A++/D)

## ACCESSORI ACCESSORIES

Filtro in ceramica anti-odori	KIT0120952A	342,00 €
Ceramic odour filter		

## COTTURA COOKING

	ONE HP	ONE
Comandi Controls	Touch control direct slider 9P+I	Touch control 9P+I
	9P+B slider touch control direct	9P+B touch control
Assorbimento	7,2 KW	7,2 KW
Absorption		
Power limitation	4,5 kW	3,1 - 4,3 kW
Voltaggio Voltage	220 - 240 V	220 - 240 V
Zone cottura	1 200x180 mm - 2,1/3,7 kW	1 200x180 mm - 1,6/1,85 kW
Cooking zones		
(Misura-Potenza	2 200x180 mm - 2,1/3,7 kW	2 200x180 mm - 2,1/3 kW
Size-Power)		
Zone Bridge	3 200x180 mm - 2,1/3,7 kW	3 Ø200 mm - 2,3/3,0 kW
Bridge zone	4 200x180 mm - 2,1/3,7 kW	4 Ø160 mm - 1,2/1,4 kW
	2	1 sinistra left

## FUNZIONI FUNCTIONS

### ONE HP



CHILD LOCK



TIMER



BRIDGE ZONES



POT DETECTOR



POWER LIMITATION



STOP & GO



PAUSE



TEMPERATURE  
MANAGER

### ONE



CHILD LOCK



TIMER



BRIDGE ZONES



POT DETECTOR



POWER LIMITATION



KEEP WARM

## MODELLI MODELS

NIKOLATESLA BL/A/83	PRF0120977A	2.667,00 €
NIKOLATESLA BL/F/83 (*)	PRF0120978A	3.122,00 €
NIKOLATESLA HP BL/A/83	PRF0120975A	3.674,00 €
NIKOLATESLA HP BL/F/83 (*)	PRF0120976A	4.145,00 €

(\*) Modello non soggetto a certificazione energetica obbligatoria.

(\*) Model not subject to compulsory energy certification.





# NIKOLATESLA LIBRA

DESIGN FABRIZIO CRISÀ







# NIKOLATESLA LIBRA

DESIGN FABRIZIO CRISÀ

83x51x21 cm

80,7x49,2 cm (cut)

Aspirante/Filtrante Duct-out/Filtering

Vetro nero + ghisa, vetro bianco "ICE GREY" + ghisa

Black glass + cast iron, white glass "ICE GREY" + cast iron



Il piano aspirante con bilancia integrata. Il design delle solide griglie veste le funzionalità dell'aspirazione dal basso e della pesatura, che si integrano armoniosamente a quelle della cottura ad induzione.

The extractor top with built-in scale. The design of the solid grids

includes the down-draft extraction and weighing function which integrate seamlessly with the induction hob functions.

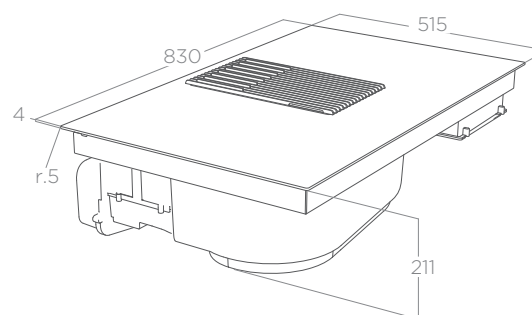

## ASPIRAZIONE ASPIRATION

	ASPIRANTE DUCT-OUT	FILTRANTE FILTERING
Comandi Controls	Touch control slider 3V+2I 3S+2B slider touch control	Touch control slider 3V+2I 3S+2B slider touch control
Portata intensiva Booster airflow	610 m <sup>3</sup> /h	545 m <sup>3</sup> /h
Velocità di aspirazione Suction speed	5,1 m/s	5,1 m/s
Livello sonoro min-max Noise level min-max	46 - 63 db(A)	48 - 67 db(A)
Assorbimento totale Total absorption	250 W	250 W

Filtro grassi alluminio incluso Grease aluminium Filter included

Filtro in ceramica anti-odori incluso (\*) Ceramic odour filter included (\*)



LONG LIFE  
FILTER ++



EASY TO  
MAINTAIN



AUTO  
CAPTURE



222x89 mm



ENERGY  
CLASS  
(A+++/D)

## ACCESSORI ACCESSORIES

Filtro in ceramica anti-odori Ceramic odour filter	KIT0120952A	342,00 €
---	-------------	----------

## COTTURA COOKING

Comandi Controls	Touch control slider 9P+I 9P+B slider touch control
Assorbimento Absorption	7,2 KW
Power limitation	3,1 - 4,5 KW
Voltaggio Voltage	220 - 240 V
Zone cottura Cooking zones (Misura-Potenza Size-Power)	1 200x180 mm - 1,6/1,85 KW 2 200x180 mm - 2,1/3 KW 3 200x180 mm - 2,1/3 KW 4 200x180 mm - 1,6/1,85 KW
Zone Bridge Bridge zone	2

## FUNZIONI FUNCTIONS



CHILD LOCK



TIMER



BRIDGE  
ZONES



POT  
DETECTOR



POWER  
LIMITATION



STOP & GO



KEEP WARM

## MODELLI MODELS

NIKOLATESLA LIBRA BL/A/83	PRF0147744A	2.597,00 €
NIKOLATESLA LIBRA BL/F/83 (*)	PRF0147745A	2.813,00 €
NIKOLATESLA LIBRA WH/A/83	PRF0147774A	2.597,00 €
NIKOLATESLA LIBRA WH/F/83 (*)	PRF0147775A	2.813,00 €

(\*) Modello non soggetto a certificazione energetica obbligatoria.

(\*) Model not subject to compulsory energy certification.



# NIKOLATESLA PRIME

DESIGN FABRIZIO CRISÀ







# NIKOLATESLA PRIME

DESIGN FABRIZIO CRISÀ



83x51x21 cm  
80,7x49,2 cm (cut)  
Aspirante/Filtrante Duct-out/Filtering  
Vetro nero + ghisa  
Black glass + cast iron



La solida e robusta griglia in ghisa coniuga la scelta di design alla funzionalità della cattura di fumi e odori al pratico piano di appoggio.

The sturdy, solid cast iron grid combines the design choice with the practical features of capturing steam and odours and the practical work surface.

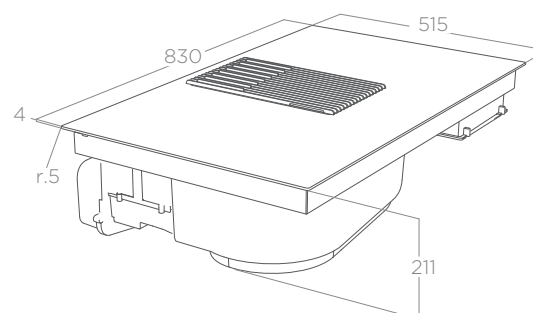

## ASPIRAZIONE ASPIRATION

	ASPIRANTE DUCT-OUT	FILTRANTE FILTERING
<b>Comandi</b> Controls	Touch control slider 3V+2I 3S+2B slider touch control	Touch control slider 3V+2I 3S+2B slider touch control
<b>Portata intensiva</b> Booster airflow	610 m <sup>3</sup> /h	545 m <sup>3</sup> /h
<b>Velocità di aspirazione</b> Suction speed	5,1 m/s	5,1 m/s
<b>Livello sonoro min-max</b> Noise level min-max	46 - 63 db(A)	48 - 67 db(A)
<b>Assorbimento totale</b> Total absorption	250 W	250 W

Filtro grassi alluminio incluso Grease aluminium Filter included  
Filtro in ceramica anti-odori incluso (\*) Ceramic odour filter included (\*)



LONG LIFE  
FILTER ++



EASY TO  
MAINTAIN



AUTO  
CAPTURE

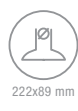

222x89 mm



ENERGY  
CLASS  
(A+++/D)

## ACCESSORI ACCESSORIES

Filtro in ceramica anti-odori Ceramic odour filter	KIT0120952A	342,00 €
---	-------------	----------

## COTTURA COOKING

<b>Comandi</b> Controls	Touch control slider 9P+I 9P+B slider touch control
<b>Assorbimento</b> Absorption	7,2 kW
<b>Power limitation</b>	3,1 - 4,5 kW
<b>Voltaggio</b> Voltage	220 - 240 V
<b>Zone cottura</b> Cooking zones (Misura-Potenza Size-Power)	1 Ø200 mm - 2,3/3,0 kW 2 Ø160 mm - 1,2/1,4 kW 3 Ø160 mm - 1,2/1,4 kW 4 Ø200 mm - 2,3/3,0 kW

## FUNZIONI FUNCTIONS



CHILD LOCK



TIMER



POT  
DETECTOR



POWER  
LIMITATION



STOP & GO



KEEP WARM

## MODELLI MODELS

NIKOLATESLA PRIME BL/A/83	PRF0138475A	2.110,00 €
NIKOLATESLA PRIME BL/F/83 (*)	PRF0143159A	2.218,00 €

(\*) Modello non soggetto a certificazione energetica obbligatoria.  
(\*) Model not subject to compulsory energy certification.







# NIKOLATESLA FLAME

DESIGN FABRIZIO CRISÀ





# NIKOLATESLA FLAME

DESIGN FABRIZIO CRISÀ

88x51x21 cm  
84x48cm (cut)  
Aspirante/Filtrante Duct-out/Filtering  
Vetro nero + ghisa, vetro grigio + ghisa  
Black glass + cast iron, grey glass + cast iron



Il primo piano aspirante gas. Gli elementi in ghisa del piano sono disegnati per coniugare estetica e funzionalità, nella massima sicurezza. Le griglie a croce chiuse e piatte garantiscono stabilità con pentole di tutte le dimensioni e facilità nello spostamento sul piano cottura. La copertura della zona filtri in ghisa diventa un pratico piano di appoggio.

Il supporto wok, disponibile come accessorio, aumenta le varianti di cottura su NikolaTesla Flame. The first gas down-draft extraction top. The cast iron elements of the top are designed to combine aesthetic appeal and functionality with the utmost safety. The closed cross and flat grid supports guarantee stability with pans of any size and ease when moving on the cooking area. The cast iron filter cover doubles as a practical work surface. The wok support, available as an accessory, increases the cooking variations on NikolaTesla Flame.

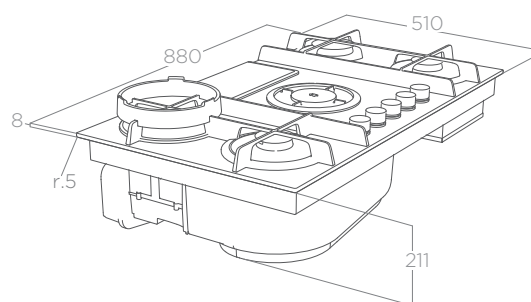

## ASPIRAZIONE ASPIRATION

	ASPIRANTE DUCT-OUT	FILTRANTE FILTERING
Comandi Controls	Rotativo 3V+2I 3S+2B Rotative	Rotativo 3V+2I 3S+2B Rotative
Portata intensiva Booster airflow	600 m <sup>3</sup> /h	550 m <sup>3</sup> /h
Velocità di aspirazione Suction speed	5,1 m/s	5,1 m/s
Livello sonoro min-max Noise level min-max	47 - 62 db(A)	53 - 68 db(A)
Assorbimento totale Total absorption	310 W	310 W

Filtro grassi alluminio incluso Grease aluminium Filter included  
Filtro fibra carbone incluso (\*) Charcoal fibre filter included (\*)



## ACCESSORI ACCESSORIES

Filtro in ceramica anti-odori Ceramic odour filter	KIT0120952A	342,00 €
Kit wok Flame	KIT0160040	86,00 €

## COTTURA COOKING

Comandi Controls	Rotativo Rotative
Voltaggio Voltage	220 - 240 V

## TIPOLOGIA BRUCIATORI BURNER TYPE

1° elemento 1st element	Dual special (3,5kW)
2° elemento 2nd element	Semi rapid (1,75 kW)
3° elemento 3rd element	Semi rapid (1,75 kW)
4° elemento 4th element	Rapid (3,0 kW)

## FUNZIONI FUNCTIONS

## MODELLI MODELS

NIKOLATESLA FLAME BL/A/88	PRF0147740A	2.057,00 €
NIKOLATESLA FLAME BL/F/88 (*)	PRF0147741A	2.166,00 €
NIKOLATESLA FLAME GR/A/88	PRF0147742A	2.057,00 €
NIKOLATESLA FLAME GR/F/88 (*)	PRF0147743A	2.166,00 €

(\*) Modello non soggetto a certificazione energetica obbligatoria.  
(\*) Model not subject to compulsory energy certification.



# NIKOLATESLA FIT

DESIGN FABRIZIO CRISÀ





# NIKOLATESLA FIT

DESIGN FABRIZIO CRISÀ





NIKOLATESLA FIT 72



NIKOLATESLA FIT 60







# NIKOLATESLA FIT

DESIGN FABRIZIO CRISÀ



60x51,5x24,5 cm 72x51,5x24,5 cm  
56x49 cm (cut)  
Aspirante Duct-out  
Vetro nero Black glass

 Possibilità di installazione nell'incasso 60 cm senza sacrificare le prestazioni della cappa, la potenza delle zone di induzione, le dimensioni e la posizione della base. Il cuore di aspirazione è completamente invisibile e può essere attivato con un semplice tocco. Le parti interne sono facilmente accessibili, per la manutenzione di filtri grassi e odori.

Can be built into 60-cm wide units without foregoing the hood performance, induction hob power, size and position of the base unit. The heart of the extraction unit is totally invisible and can be activated with a simple touch. The internal parts can be easily accessed to service the grease and odour filters.

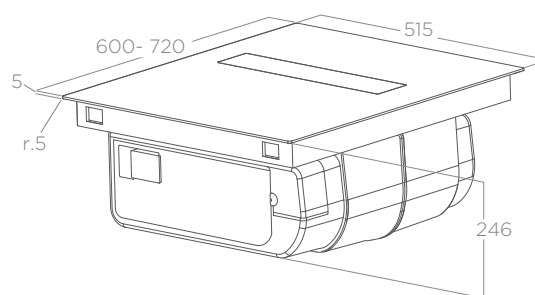

## ASPIRAZIONE ASPIRATION

Comandi Controls	Touch control slider 3V+2I 3S+2B slider touch control
Portata intensiva Booster airflow	620 m <sup>3</sup> /h
Velocità di aspirazione Suction speed	5,1 m/s
Livello sonoro min-max Noise level min-max	45 - 57 db(A)
Assorbimento totale Total absorption	160 W

## COTTURA COOKING

Comandi Controls	Touch control slider 9P+I 9P+B slider touch control
Assorbimento Absorption	7,2 kW
Power limitation	3,1 - 4,5 kW
Voltaggio Voltage	220 - 240 V
Zone cottura Cooking zones (Misura-Potenza Size-Power)	1 200x180 mm - 2,1/3,0 kW 2 200x180 mm - 1,6/1,85 kW 3 Ø200 mm - 2,3/3,0 kW 4 Ø160 mm - 1,2/1,4 kW
Zone Bridge Bridge zone	1

Filtro grassi alluminio incluso Grease aluminium Filter included



LONG LIFE  
FILTER ++



COMFORT  
SILENCE



EASY TO  
MAINTAIN



AUTO  
CAPTURE



222x89 mm



ENERGY  
CLASS  
(A<sup>++</sup>/D)

## FUNZIONI FUNCTIONS



CHILD  
LOCK



TIMER



BRIDGE  
ZONES



POT  
DETECTOR



POWER  
LIMITATION



STOP & GO



KEEP WARM

## ACCESSORI ACCESSORIES

Filtro in ceramica anti-odori Ceramic odour filter	KIT0167755	210,00 €
Kit installazione filtrante sotto zoccolo Filtering Kit plinth-in	KIT0167756	210,00 €
Kit installazione filtrante fuori zoccolo Filtering Kit plinth-out	KIT0167757	315,00 €

## MODELLI MODELS

NIKOLATESLA FIT BL/A/60	PRF0167053	2.048,00 €
NIKOLATESLA FIT BL/A/72	PRF0167054	2.090,00 €

## L'eccellenza in piccoli spazi Excellence in small spaces

Oggi i piccoli ambienti in casa sono sempre più diffusi, per questo prodotti multifunzionali e in grado di ottimizzare gli spazi sono elementi risolutivi.

Studiato per soddisfare le esigenze di chi, anche in ambienti ridotti, non vuole rinunciare all'eccellenza, NikolaTesla Fit è il primo piano a induzione con aspirazione integrata che può essere installato anche nelle basi da 60 cm, con un ingombro in superficie di 60 o 72 cm.

## Design elegante e funzionale Elegant and functional design

Un ritorno alle origini del piano cottura a induzione essenziale in cui la superficie è continua in modalità standby. Con una piccola pressione sulla parte centrale si attiva l'aspirazione in una perfetta combinazione tra stile, ergonomia e funzionalità. Le dimensioni e la forma compatte sono studiate per lasciare spazio nel cabinet e massima libertà di movimento sul piano cottura, con qualsiasi tipo di pentola. Il cuore aspirante, efficace e silenzioso, è completamente nascosto dalla copertura in vetro che veste il prodotto in modo discreto ed elegante.

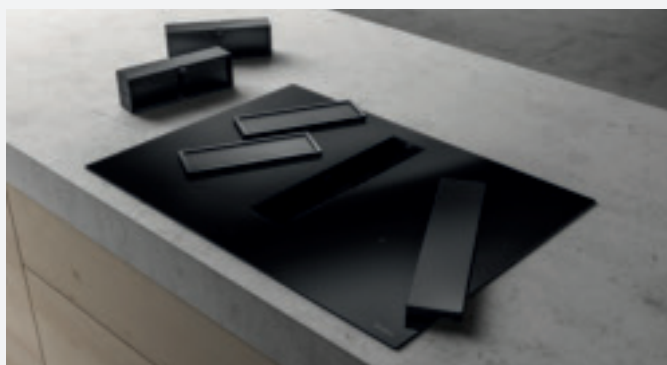

Small spaces are becoming more and more widespread in homes now which is why multifunctional products, capable of optimising space, are excellent solutions.

Designed to meet the exacting needs of those unwilling to renounce excellence even in small spaces, NikolaTesla Fit is the first induction hob with integrated extraction that can also be installed in 60-cm wide base units with an overall surface area of 60 or 72 cm.



A return to the origins of the essential induction hob where the surface is continuous and in standby mode. A slight pressure on the central part activates the extraction in a perfect combination of style, comfort and functionality. The compact dimensions and shape have been designed to leave space in the cabinet and total freedom of movement on the hob with pans of any kind. The heart of this efficient and silent extraction unit is totally concealed by the glass top which covers the product discretely and elegantly.

## Semplicità di pulizia e manutenzione

### Simple cleaning and maintenance

NikolaTesla Fit è progettato per essere davvero facile da pulire e da mantenere. La superficie completamente lineare in vetro ceramico rende le operazioni di pulizia estremamente semplici e veloci. L'elemento estetico centrale è rimovibile e lavabile e diventa il punto di accesso per l'estrazione dei filtri e la manutenzione del prodotto. È possibile accedere al vano interno in totale sicurezza e rimuovere l'eventuale liquido in eccesso grazie ad una speciale valvola di scarico posta sul fondo.

NikolaTesla Fit is designed to be really easy to clean and maintain. The fully linear ceramic glass surface makes cleaning very quick and easy. The central aesthetic element can be removed and washed. It is also the access point for extracting the filters and carrying out maintenance. The inner compartment can be accessed in complete safety and any excess liquid can be removed thanks to a special drain valve underneath.

## Massima flessibilità di installazione Full installation flexibility

Nikolatesla Fit è stato progettato per adattarsi alle più varie configurazioni di installazione. Questi sono i principali esempi delle sue infinite possibilità realizzabili con le tubazioni a disposizione a pagina seguente.

Nikolatesla Fit has been designed to adapt to the most varied installation configurations. These are the main examples of the infinite range of possibilities that can be developed using the available piping on the following page.

\* le tubazioni sono ordinabili come accessori The pipes are available as accessories

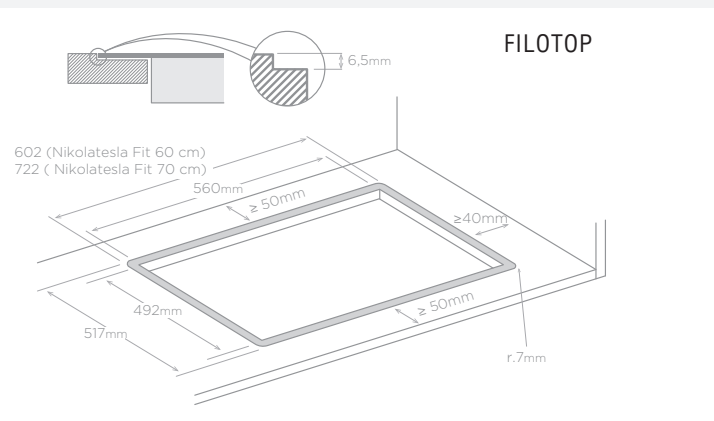
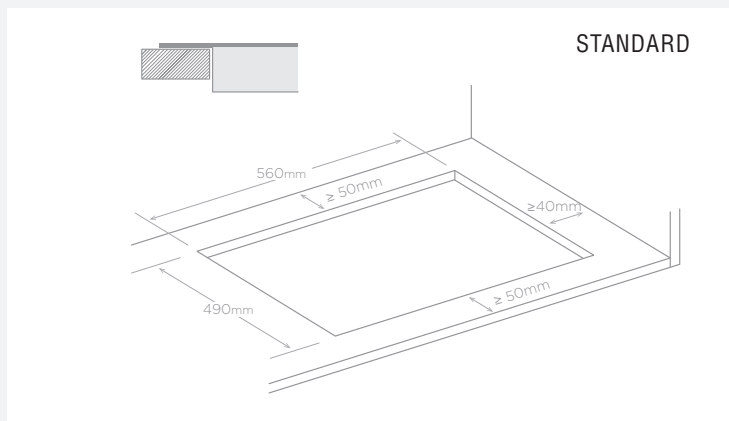
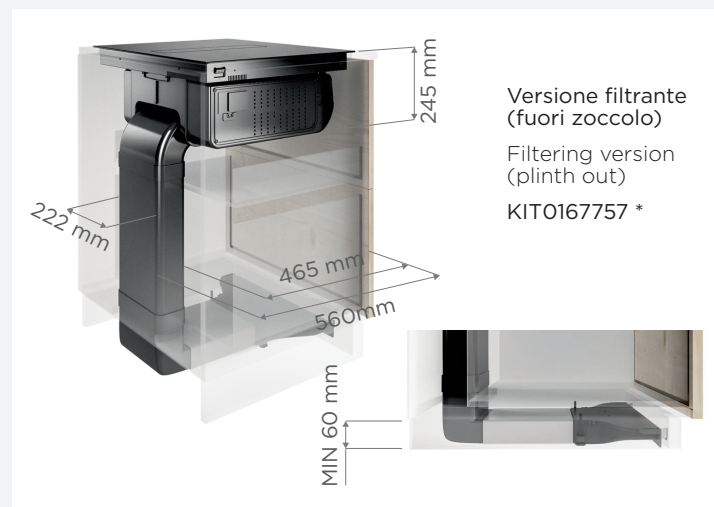
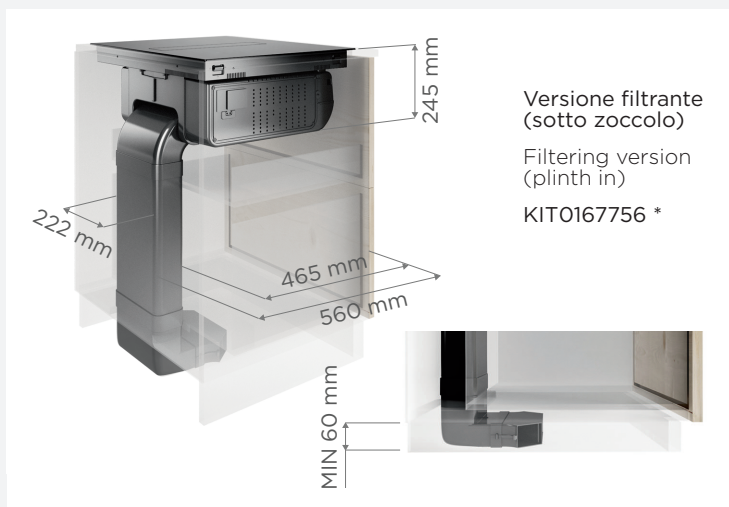
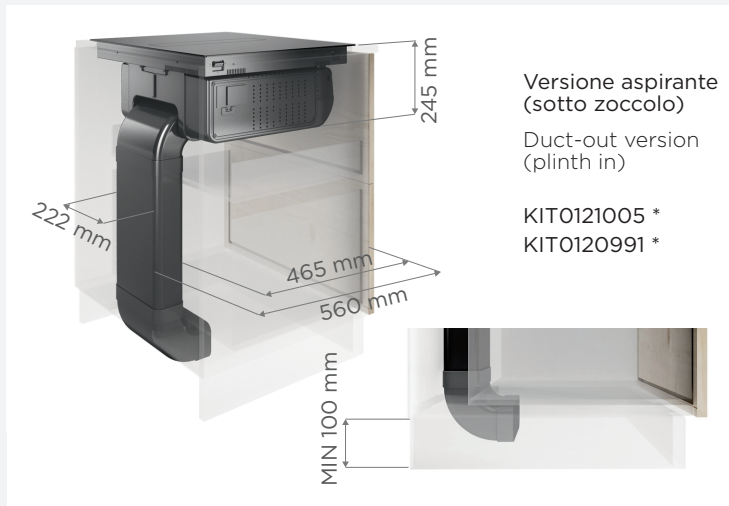

Dimensioni consigliate filotop: per tolleranze differenti, attenersi alla reale dimensione del vetro.  
Recommended filotop dimensions: for different tolerances, respect the actual dimensions of the glass.  
PER ULTERIORI APPROFONDIMENTI CONSULTARE IL MANUALE DI INSTALLAZIONE DEL PRODOTTO.  
FOR FURTHER INFORMATION, CONSULT THE PRODUCT INSTALLATION MANUAL.

## TUBAZIONI ACCESSORIE PER VERSIONE ASPIRANTE ACCESSORY PIPE FITTINGS FOR DUCT-OUT VERSION



222x89x1000 mm

KITO120991

42,00 €



222x89x500 mm

KITO173527

32,00 €



Ø150x500 mm

KITO120996

27,00 €



Ø150x1000mm

KITO121000

48,00 €



227x94x80mm

KITO121001

14,00 €



15° 227x138x94

KITO121002

29,00 €



Ø158x59mm

KITO121003

10,00 €



90° 227x288x94mm

KITO121004

37,00 €



90° 227x94mm

KITO121005

33,00 €



90° - Ø157

KITO121006

39,00 €



227x94 - Ø146mm

KITO121007

33,00 €



227x94 - Ø153mm

KITO121008

31,00 €

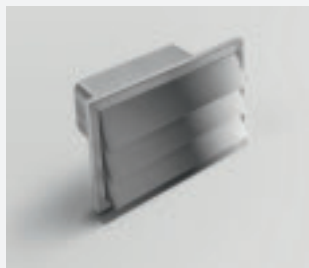

int 216x82 / est 290x160 mm

KITO121009

221,00 €

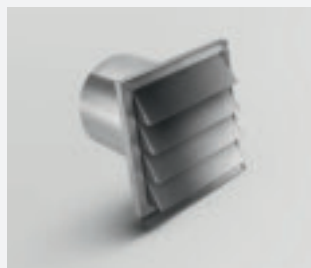

190x190 - Ø147mm

KITO121010

217,00 €



227x94 mm

KITO126810

114,00 €

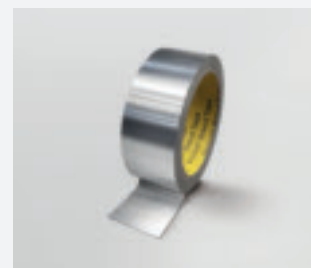

50 mm x 25 m

KITO161453

37,00 €

## TUBAZIONI ACCESSORIE PER VERSIONE FILTRANTE ACCESSORY PIPE FITTINGS FOR FILTERING VERSION



218x55x500 mm  
KITO121012 21,00 €



218x55x1000 mm  
KITO121013 37,00 €



218x55x70 mm  
KITO121015 10,00 €



90° 218x55 mm  
KITO121016 21,00 €



218x55 mm  
KITO121017 35,00 €



50 mm x 25 m  
KITO161453 37,00 €



Deflettore sotto zoccolo  
Deflector under plinth  
KITO168750 37,00 €

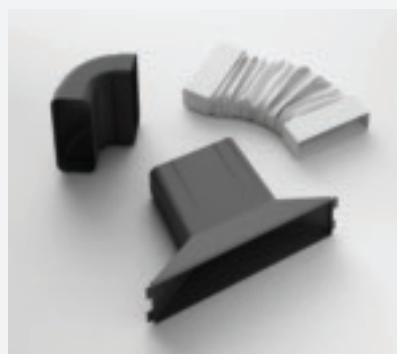

DISPONIBILE PER  
Available for  
NIKOLATESLA SWITCH  
NIKOLATESLA ONE  
NIKOLATESLA PRIME  
NIKOLATESLA FLAME  
NIKOLATESLA LIBRA

KITO140820 142,00 €  
Kit NikolaTesla filtrante per base profondità > 70 cm  
NikolaTesla filter kit for base depth > 70 cm



DISPONIBILE PER  
Available for  
NIKOLATESLA FIT

KITO167756 210,00 €  
Kit installazione filtrante sotto zoccolo (min H6 cm)  
Filtering Kit plinth-in (min H6 cm)



DISPONIBILE PER  
Available for  
NIKOLATESLA FIT

KITO167757 315,00 €  
Kit installazione filtrante fuori zoccolo (min H6 cm)  
Filtering Kit plinth-out (min H6 cm)



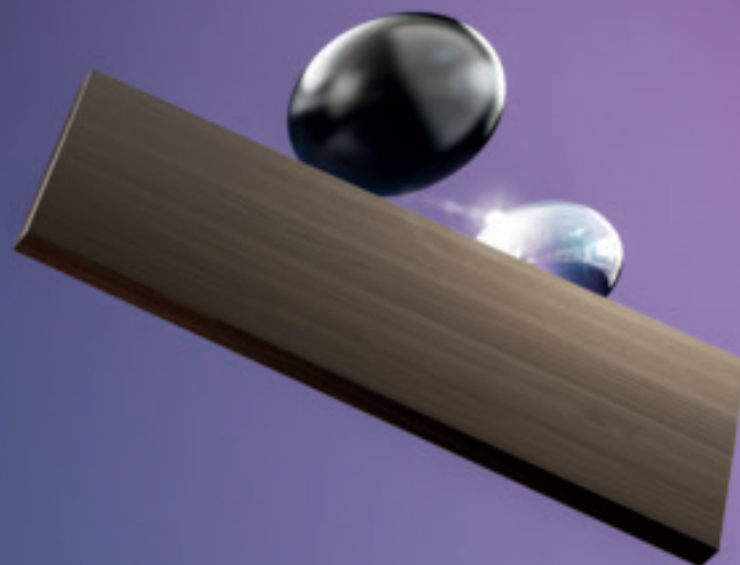

# ARCH & LIGHTAIR

Viviamo di intuizioni che diventano il punto di partenza di ogni progetto e rappresentano l'incontro tra chi l'ha disegnato e chi lo utilizzerà. Il design dà vita a queste intuizioni che si trasformano in prodotti capaci di parlare di se stessi in modo intuitivo e di sorprendere sempre con funzioni inattese. I prodotti Arch & Lightair si fondono nell'architettura dell'ambiente ma al contempo ne diventano essi stessi i protagonisti. Sono la sintesi tra visione, tecnologia e creatività.

We live by intuitions, which become the starting point of every project and which represent the meeting point between the designer and user. It is design that gives life to these intuitions, which are transformed into products able to express themselves in intuitive ways, and continuously surprise with unexpected functions. Arch & Lightair products blend into the room's architecture, but at the same time become the protagonists themselves. They are the synthesis of vision, technology, and creativity.





# OPEN SUITE SUPERIOR

DESIGN FABRIZIO CRISÀ





# OPEN SUITE SUPERIOR

DESIGN FABRIZIO CRISÀ







# OPEN SUITE SUPERIOR

DESIGN FABRIZIO CRISÀ







# OPEN SUITE SUPERIOR

DESIGN FABRIZIO CRISÀ

ELICA CONNECT



80x424 - 160x424 cm

Filtrante Filtering

Nero effetto soft touch Black soft touch effect



EASY TO MAINTAIN



MULTI-D CAPTURE



CONNECTIVITY



LONG LIFE FILTER



TUNE WHITE



DIM LIGHT



CM 60



CM 70

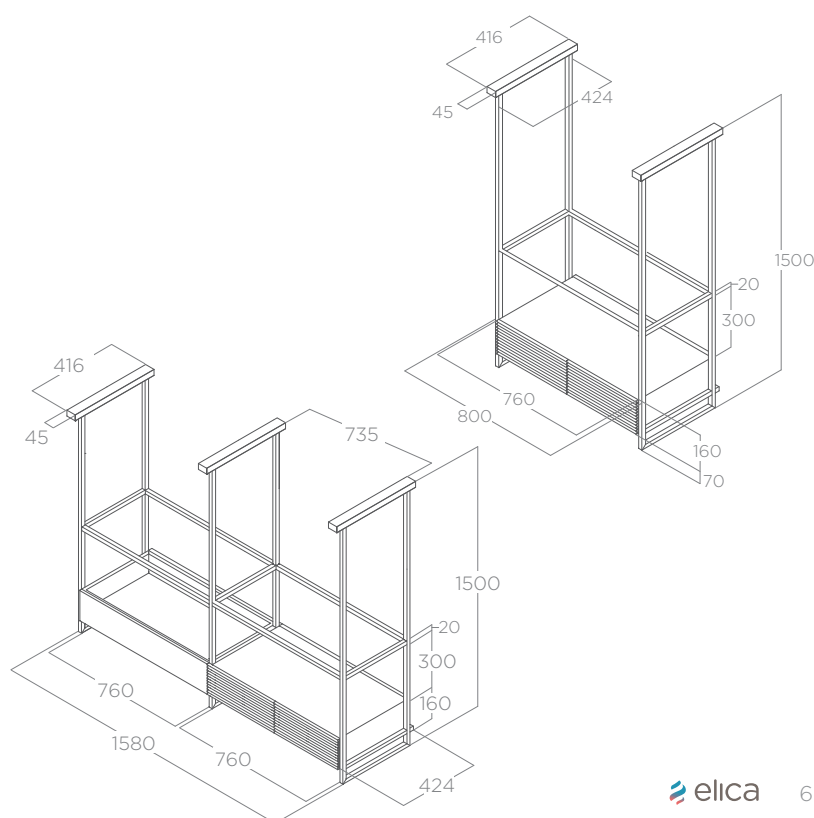

## ILLUMINAZIONE LIGHTING

Tipo Type	Led Panel 1x14W (80cm) - 2x14W (160cm)
Intensità Intensity	242 LUX (80cm) - 324 LUX (160cm)
Temperatura Temperature	2700K - 5200K

## PERFORMANCE PERFORMANCE

Comandi Controls	Pulsantiera elettronica 3V+2I 3S+2B Electronic push button
Portata intensiva Booster airflow	526 m <sup>3</sup> /h
Livello sonoro min-max Noise level min-max	64 - 69 db(A)
Assorbimento totale Total absorption	261 W (80cm) - 282 W (160cm)

Filtro grassi alluminio incluso Grease aluminium filter included

Filtro carbone rigenerabile incluso Regenerable charcoal filter included

## ACCESSORI ACCESSORIES

Filtro carbone rigenerabile 2 pezzi 2 pieces Regenerable charcoal filter	KIT0166765	110,00 €
Kit modulo aspirante Superior Extraction module kit Superior	KIT0167079	2.000,00 €
Kit modulo full Led Superior Full LED module kit Superior	KIT0166961	1.200,00 €
Kit mensola vetro extra-chiaro Extra-clear glass shelf kit	KIT0166455	100,00 €
Kit mensola vetro fumé Smoked glass shelf kit	KIT0166463	100,00 €
Kit mensola metallo nero Black metal shelf kit	KIT0166470	100,00 €
Kit mensola rete metallica Wire mesh shelf kit	KIT0166472	100,00 €
Kit mensola legno Wooden shelf kit	KIT0166475	150,00 €
Kit traliccio Superior Trellis expansion kit Superior	KIT0166962	400,00 €
Kit cornice mensola Shelf frame kit	KIT0166768	250,00 €

## MODELLI MODELS

OPEN SUITE SUPERIOR BL/F/80	PRF0165965	2.700,00 €
OPEN SUITE SUPERIOR BL/F/160	PRF0166771	4.100,00 €

Modello non soggetto a certificazione energetica obbligatoria.  
Model not subject to compulsory energy certification.







# OPEN SUITE

DESIGN FABRIZIO CRISÀ



# OPEN SUITE

DESIGN FABRIZIO CRISÀ

# OPEN SUITE

DESIGN FABRIZIO CRISÀ







# OPEN SUITE

ELICA CONNECT

DESIGN FABRIZIO CRISÀ

80 - 160 cm

Filtrante Filtering

Nero effetto soft touch Black soft touch effect



EASY TO MAINTAIN



MULTI-D CAPTURE



CONNECTIVITY



LONG LIFE FILTER



TUNE WHITE



DIM LIGHT



CM 60



CM 70

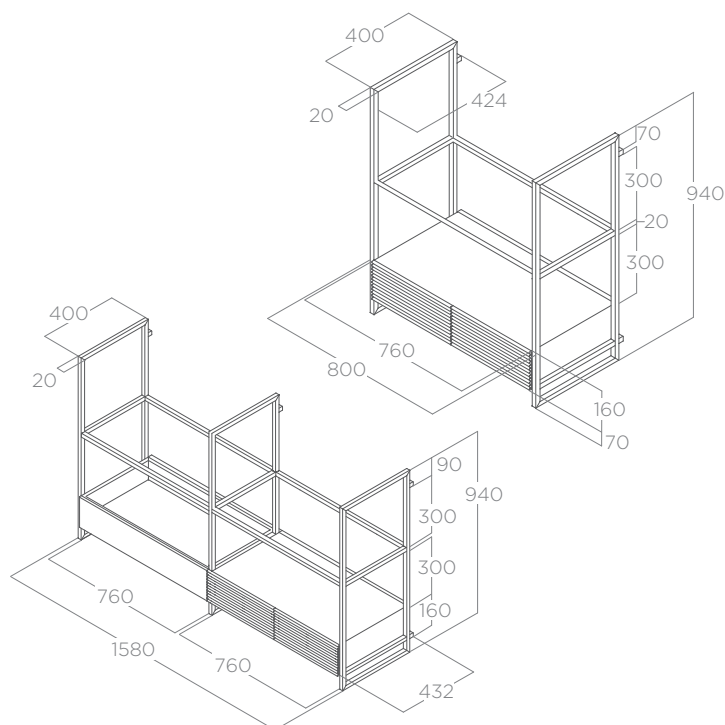

## ILLUMINAZIONE LIGHTING

Tipo Type	Led Panel 1x14W (80cm) - 2x14W (160cm)
Intensità Intensity	242 LUX (80cm) - 324 LUX (160cm)
Temperatura Temperature	2700K - 5200K

## PERFORMANCE PERFORMANCE

Comandi Controls	Pulsantiera elettronica 3V+2I 3S+2B Electronic push button
Portata intensiva Booster airflow	526 m <sup>3</sup> /h
Livello sonoro min-max Noise level min-max	64 - 69 db(A)
Assorbimento totale Total absorption	261 W (80cm) - 282 W (160cm)

Filtro grassi alluminio incluso Grease aluminium filter included  
Filtro carbone rigenerabile incluso Regenerable charcoal filter included

## ACCESSORI ACCESSORIES

Filtro carbone rigenerabile 2 pezzi 2 pieces Regenerable charcoal filter	KIT0166765	110,00 €
Kit modulo aspirante Extraction module kit	KIT0167073	2.000,00 €
Kit modulo full Led Full LED module kit	KIT0166964	1.200,00 €
Kit mensola vetro extra-chiaro Extra-clear glass shelf kit	KIT0166455	100,00 €
Kit mensola vetro fumé Smoked glass shelf kit	KIT0166463	100,00 €
Kit mensola metallo nero Black metal shelf kit	KIT0166470	100,00 €
Kit mensola rete metallica Wire mesh shelf kit	KIT0166472	100,00 €
Kit mensola legno Wooden shelf kit	KIT0166475	150,00 €
Kit traliccio Trellis expansion kit	KIT0166963	400,00 €
Kit cornice mensola Shelf frame kit	KIT0166768	250,00 €

## MODELLI MODELS

OPEN SUITE BL/F/80	PRF0166703	2.500,00 €
OPEN SUITE BL/F/160	PRF0167007	3.900,00 €

Modello non soggetto a certificazione energetica obbligatoria.  
Model not subject to compulsory energy certification.

## Arredare gli spazi polifunzionali

### Furnishing multi-functional spaces

Innovazione è intuire il cambiamento ed immaginare il domani con idee e soluzioni che migliorino l'esperienza di vita delle persone. Open Suite è un prodotto unico, capace di occupare lo spazio in modo nuovo ed inaspettato e di offrire funzionalità inedite. La cappa aspirante diventa parte di un sistema fatto di elementi che interagiscono tra loro e si uniscono dando vita a infinite soluzioni di arredo dove la luce è protagonista.

Innovation is sensing change and imagining tomorrow with ideas and solutions that improve people's experience of life. Open Suite is a unique product, capable of occupying space in a new, unexpected way and of offering previously unseen functionality. The extractor hood becomes part of a system made up of elements that interact and, together, offer infinite furnishing solutions in which light is the star.



## Forme, materiali e luce in una innovativa soluzione modulare

### Shapes, materials, and light in an innovative, modular solution



Nei contesti in cui l'arredamento della zona living gioca un ruolo essenziale, Open Suite è l'alleata perfetta. La sua struttura modulare, personalizzabile, dallo stile unico è immediatamente riconoscibile e dona carattere all'ambiente. I tralicci sono verniciati in nero soft touch e la bocca di aspirazione è arricchita da griglie effetto ghisa.

In settings in which the furniture in the living area plays an essential role, Open Suite is the perfect ally. Its modular, customisable structure, with a unique style, is immediately recognisable and adds character to the environment. The latticework is painted in soft touch black and the extractor opening features cast iron effect grids.

#### DESIGN MODULARE

Open Suite racchiude in sé più funzioni: non solo cappa ma anche luce e una vasta scelta di ripiani da arredo. Si parte da quattro configurazioni preimpostate (isola 80 e 160cm, parete 80 e 160cm) che possono essere sia una soluzione completa, sia la base da cui partire per aggiungere complementi. L'ampia scelta di elementi e finiture disponibili include ripiani in vetro (chiaro e smoke), metallo e rete metallica neri, legno (noce o personalizzabile), ma anche moduli aspiranti e pannelli luminosi aggiuntivi per aumentare la potenza aspirante o espandere il punto luce sul piano di lavoro. Nella versione a isola, l'altezza della struttura è regolabile per consentire l'installazione all'interno di ogni ambiente, indipendentemente dalla misura del soffitto. Realizza la tua versione unica di Open Suite giocando con gli spazi e ricreando linee e geometrie in base ai tuoi gusti personali e allo stile dell'arredamento.

#### MODULAR DESIGN

Open Suite offers several functions: not only a hood but also light and a wide choice of shelves. It comes with four pre-set configurations (island 80cm and 160cm, wall 80cm and 160cm) that can be both a complete solution and the base from which to add accessories. The wide choice of available elements and finishings include glass shelves (clear and smoke), black metal and metallic mesh, wood (walnut or customisable), but also extractor modules and additional light panels to increase the extraction power or expand the light point across the work surface. In the island version, the height of the structure is adjustable to allow installation inside any environment, regardless of the height of the ceiling. Create your own unique version of Open Suite by playing with spaces and recreating lines and geometries according to your personal taste and the style of your furniture.

## Luce funzionale ed emozionale, un autentico elemento di arredo Functional and evocative light, a genuine piece of furniture

La luce è uno dei caratteri distintivi di Open Suite: mentre la nuova soluzione di installazione elimina efficacemente e silenziosamente tutti gli odori dall'ambiente, il grande pannello led, potente ed efficiente, assicura un'illuminazione uniforme, adattabile in intensità e in temperatura di colore. Così Open Suite diventa un punto luce strategico durante la preparazione dei cibi ma anche una luce ambiente di grande atmosfera durante i momenti più conviviali, sempre in perfetta armonia con lo spazio circostante.

La superficie illuminante è massima e perfettamente ottimizzata, sia nella soluzione base da 80cm che in quelle più estese equipaggiate con pannelli full led aggiuntivi.

Light is one of the distinctive features of Open Suite: whilst the new installation solution effectively and silently eliminates smells from the environment, the large LED panel, powerful and efficient, ensures uniform lighting, that can be adjusted in intensity and colour temperature. This is how Open Suite becomes a strategic light point when preparing food, but also ambient lighting creating a great atmosphere for any occasion, always in perfect harmony with the surrounding space. The illuminating surface is maximised and perfectly optimised, both in the base 80cm solution and in the larger solutions equipped with additional LED panels.



## Connessione Wi-Fi Wifi connection

Disegnata per garantire la massima libertà di movimento in cucina, oltre ai comandi ergonomici collocati frontalmente, Open Suite fa parte della linea di cappe intelligenti Elica Connect. Tramite il controllo vocale o la app Elica Connect è possibile accendere o spegnere il prodotto, regolarne la potenza di aspirazione e modulare l'intensità della luce. La App consente inoltre di monitorare lo stato di efficienza dei filtri e di richiedere qualsiasi tipo di assistenza con pochi click.

Designed to ensure the greatest freedom of movement in the kitchen, in addition to the front-positioned ergonomic controls, Open Suite is part of the line of Elica Connect intelligent hoods. Using voice commands or the Elica Connect app, you can turn the product on and off, adjust its extraction power, and modulate the intensity of the light. The App also lets you monitor the efficiency of the filters and to seek any sort of assistance with just a few clicks.

ELICA CONNECT



## Open Suite nella scatola

### Open Suite in the box

Grazie agli accessori a disposizione, potete realizzare infinite composizioni in base all'architettura del vostro ambiente e alle vostre necessità, partendo dalle due versioni base ordinabili a catalogo.

Thanks to the available accessories, you can create an unlimited number of arrangements based on the structure of your environment and your needs, starting with the two base versions that can be ordered in the catalogue.

### OPEN SUITE SUPERIOR (VERSIONE A ISOLA)

#### OPEN SUITE SUPERIOR (ISLAND VERSION)



OPEN SUITE SUPERIOR BL/F/80  
Modulo cappa + 1 mensola in vetro chiaro (80cm)  
Hood module + 1 shelf in clear glass (80cm)

PRF0165965



OPEN SUITE SUPERIOR BL/F/160  
1 modulo cappa + 1 modulo luce + 2 mensole in vetro chiaro (160cm)  
1 hood module + 1 light module + 2 shelves in clear glass(160cm)

PRF0166771

### OPEN SUITE (VERSIONE A PARETE)

#### OPEN SUITE (WALL VERSION)



OPEN SUITE BL/F/80  
Modulo cappa + 1 mensola in vetro chiaro (80cm)  
Hood module + 1 shelf in clear glass (80cm)

PRF0166703



OPEN SUITE BL/F/160  
1 modulo cappa + 1 modulo luce + 2 mensole in vetro chiaro (160cm)  
1 hood module + 1 light module + 2 shelves in clear glass(160cm)

PRF0167007

### ALCUNE IDEE DI COMPOSIZIONE PER SOLUZIONI A ISOLA

#### SOME ARRANGEMENT IDEAS FOR ISLAND SOLUTIONS

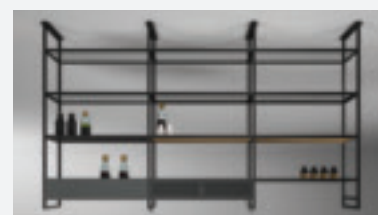
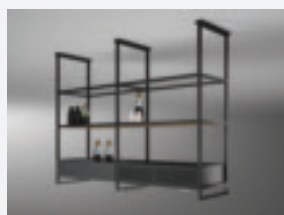
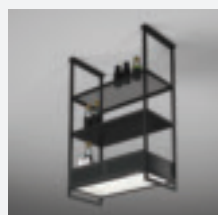



## Accessori e modularità Accessories and modularity



Sia per la versione a isola che a parete, partendo dai due prodotti base, puoi scegliere di personalizzare la tua Open Suite in altezza, aggiungendo o sostituendo i ripiani.

Both for the island version and the wall version, starting from the two base products, you can choose to customise the height of your Open Suite, adding or replacing shelves.

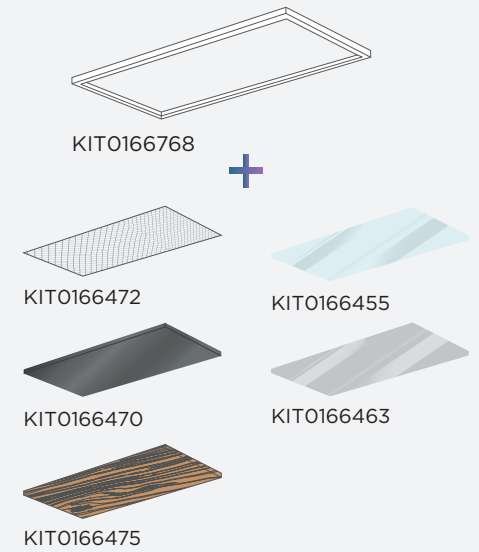
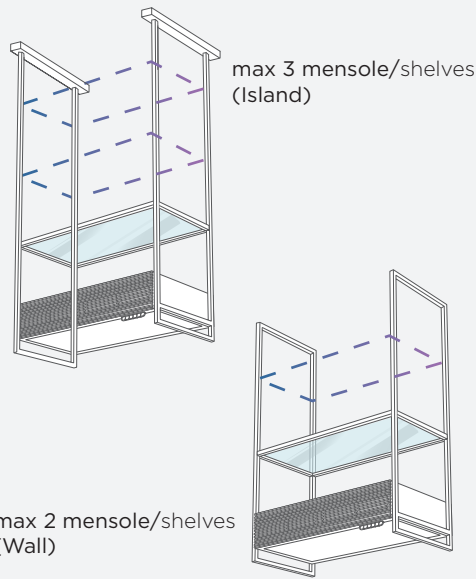

Puoi comporre la Open Suite più adatta al tuo ambiente muovendoti anche in larghezza, aggiungendo, tramite tralicci di collegamento, moduli cappa, moduli luce o mensole.

You can put together the Open Suite that best fits your environment, even creating wider versions by adding - through the latticework connectors - hood modules, light modules or shelves.

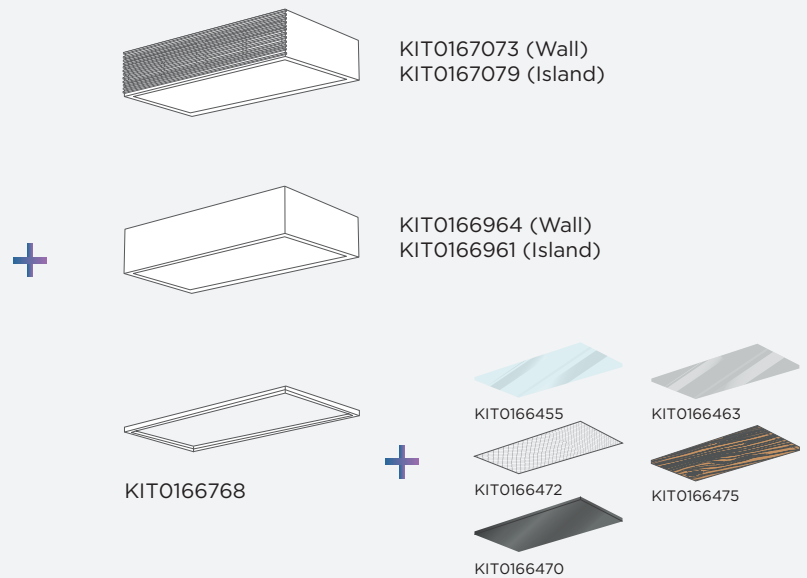
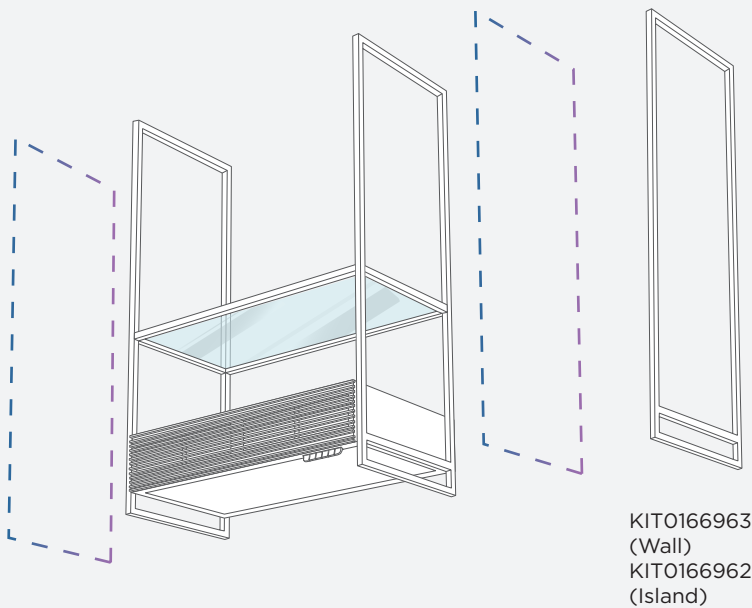

### ALCUNE IDEE DI COMPOSIZIONE PER SOLUZIONI A PARETE SOME ARRANGEMENT IDEAS FOR WALL SOLUTIONS







# IKONA MAXXI PURE

DESIGN FABRIZIO CRISÀ



# IKONA MAXXI PURE

DESIGN FABRIZIO CRISÀ







# IKONA MAXXI PURE ELICA AIR PURE

DESIGN FABRIZIO CRISÀ

120 x 44 cm

Filtrante Filtering

Acciaio inox, nero effetto soft touch Stainless steel, black soft touch effect

## ILLUMINAZIONE LIGHTING

Tipo Type	Strip Led 1x7 W
Intensità Intensity	365 LUX
Temperatura Temperature	3500 K

## PERFORMANCE ASPIRAZIONE (MOTORE 1) EXTRACTION PERFORMANCE (MOTOR 1)

Comandi Controls	Pulsantiera elettronica 3V+I 3S+B Electronic push button
Portata intensiva Booster airflow	600 m³/h
Livello sonoro min-max Noise level min-max	47 - 62 db(A)
Assorbimento totale Total absorption	200 W

Filtro grassi alluminio incluso Grease aluminium filter included

Filtro carbone rigenerabile incluso Regenerable charcoal filter included



EASY TO MAINTAIN



CM 50



CM 60



Ø150



ENERGY CLASS (A+++D)

## ACCESSORI ACCESSORIES

Filtro carbone rigenerabile Regenerable charcoal filter	CFC0162221	104,00 €
Filtro Hepa-Carbone Hepa-Charcoal filter	KIT0176157	80,00 €
Kit camino nero Black chimney kit	KIT0175017	160,00 €
Kit camino acciaio inox Stainless steel chimney kit	KIT0175018	190,00 €
Kit installazione a parete acciaio inox Stainless steel wall installation kit	KIT0175807	206,00 €
Kit installazione a parete nero Black wall installation kit	KIT0175808	206,00 €
Kit prolunga cavi (5m) Extension cable kit (5m)	KIT0147942	196,00 €
Kit prolunga cavi (2,5m) Extension cable kit (2,5m)	KIT0147941	163,00 €

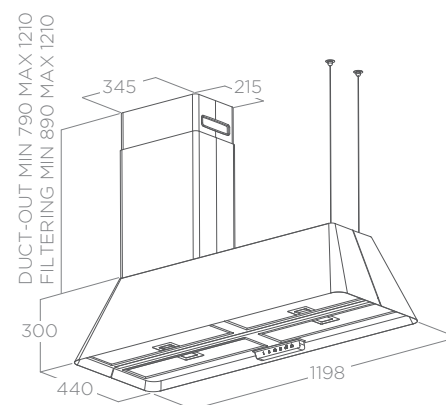

## PERFORMANCE PURIFICAZIONE (MOTORE 2) PURIFICATION PERFORMANCE (MOTOR 2)

Comandi Controls	Pulsantiera elettronica 2V 2S Electronic push button
Per stanze fino a For room up to	30 m²
Livello sonoro min-max Noise level min-max	37 - 66 db(A)
Assorbimento totale Total absorption	175 W
Particelle filtrate Filtered particles	Acari della polvere/polvere, peli di animali, pollini, muffe, fumo di sigaretta, combustibili per stufe, formaldeide (pitture e rivestimenti), odori di cottura. Dust/dust mites, animal dander, pollens, molds, cigarettes smoke, stoves combustibles, formaldehyde (paintings and coating), cooking odors.



MULTIFUNCTION



COMBO PURE FILTER



PURE SILENCE

## MODELLI MODELS

IKONA MAXXI PURE BL MAT/F/120	PRF0171195	1.900,00 €
IKONA MAXXI PURE IX/F/120	PRF0171196	1.900,00 €



Il motore della cappa e quello del purificatore sono azionabili con un'interfaccia dedicata e funzionano alternativamente l'uno dall'altro. Il camino, disponibile come accessorio sia per la versione aspirante che per quella filtrante, può essere installato sopra il motore cappa, a destra o a sinistra. The motor of the hood and purifier can be activated from a dedicated interface and operate alternately to each other. The chimney, available as an accessory for filtering and duct-out versions, can be installed above the hood motor, either on the right or left.

## Il benessere in casa tua: stile e aria pura. Wellness in your own home: style and pure air.



Oggi la cucina e il living sono uno spazio unico dove viviamo molti momenti della giornata e in cui cerchiamo comfort e benessere attraverso arredi dalle forme armoniose ed eleganti, illuminazione piacevole, nessun rumore fastidioso ma soprattutto aria purificata da respirare. A questo scopo, Elica crea Ikona Maxxi Pure, un valido aiuto per mantenere il giusto equilibrio della qualità dell'aria nella zona living, e che diventerà parte della tua routine quotidiana.

Today, the kitchen and living are a single space where we spend much of our day, in which we seek comfort and wellness through harmonious and elegant furnishings, pleasant lighting, the absence of annoying noises, but above all, the purified air that we breathe. With this in mind, Elica has created Ikona Maxxi Pure, a valuable aid in ensuring the right balance of the air quality in the living area, which will become part of your daily routine.

## Un prodotto multifunzione che si prende cura dell'aria indoor A multifunctional product that looks after indoor air

Ikona Maxxi Pure incorpora, in un elegante oggetto di arredo, una cappa e un purificatore d'aria che si prendono cura due volte dell'aria della casa. È stato pensato per migliorare la qualità dell'aria domestica senza bisogno di installare dispositivi aggiuntivi o sistemi di monitoraggio complessi, spesso scomodi e ingombranti.

Ikona Maxxi Pure è stato progettato per far funzionare in modo indipendente cappa e purificatore, senza alcun compromesso in termini di prestazioni e fruibilità. Il "cuore cappa" di Ikona Maxxi Pure elimina in modo efficace i vapori e gli odori della cottura. In alternativa, azionando il suo purificatore, sarà possibile liberare l'aria della zona giorno da allergeni e inquinanti, fornendo un aiuto concreto nel combattere sintomi allergici e malesseri respiratori legati presenza di agenti chimici, donando una sensazione di salute e di buonumore durante l'intera giornata.



Ikona Maxxi Pure incorporates, in an elegant furnishing, a hood and air purifier that take twofold care of the home's air. It has been designed to improve the quality of domestic air without needing to install additional devices or complex monitoring systems which are often impractical and invasive. Ikona Maxxi Pure has been designed to allow the hood and purifier to operate independently, without compromising on either performance or usability. The "hood core" of Ikona Maxxi Pure efficiently eliminates cooking fumes and vapours. Alternatively, by activating its purifier, the air in the living area can be freed of allergens and pollutants, providing an effective aid in combating allergy symptoms and breathing ailments tied to the presence of chemical agents, offering a sense of well-being and tranquillity all throughout the day.



## Purificazione dell'aria super silenziosa

### Super-silent air purification



Ikona Maxxi Pure è in grado di purificare completamente l'aria di un ambiente di 30m<sup>2</sup> in soli 20 minuti. Il purificatore d'aria è dotato di uno speciale filtro combinato HEPA-carbone e può catturare particelle piccole fino a 1 micron. Ha due modalità: "Boost" per una pulizia intensiva dell'aria, e "Super Silent", perfetta per purificare silenziosamente la stanza lavorando in background.

Ikona Maxxi Pure is able to completely purify the air in a 30m<sup>2</sup> space in just 20 minutes. The air purifier is fitted with a special combined HEPA-carbon filter and can capture particles as small as 1 micron. It has two operating modes: "Boost" for intensive air cleaning, and "Super Silent", perfect for silently purifying the room, working in the background.



#### COMBO PURE FILTER (HEPA-CARBONE)

##### COMBO PURE FILTER (HEPA-CARBON)

Lo speciale Combo Pure Filter, un combinato di Hepa e carbone, cattura gli agenti inquinanti liberando la zona living da odori e allergeni come polvere, peli di animali, pollini, muffe e residui dannosi prodotti da detersivi per la pulizia della casa, pitture e rivestimenti. Per mantenere efficace la purificazione dell'aria, il filtro deve essere sostituito circa una volta all'anno. Ikona Maxxi Pure ti ricorderà di cambiarlo tramite un avviso sull'interfaccia utente, a garanzia di respirare sempre aria sana.

The special Combo Pure Filter, a combined Hepa and carbon filter, captures polluting agents, freeing the living area of unpleasant odours and allergens such as dust, animal hair, pollen, mould, and harmful residues produced by household detergents, paints and coverings. To maintain the efficiency of air purification, the filter must be replaced more or less once per year. Ikona Maxxi Pure will remind you to change it through an alert on the user interface to ensure the air you breaths is always healthy.

## Il design che si adatta ad ogni living

### A design that adapts to any living space



Il design senza tempo di Ikona Maxxi Pure si adatta perfettamente ad ogni ambiente open space. Il prodotto è disponibile nelle finiture soft black matt o inox. Può essere installato in modalità filtrante o aspirante, sospeso o a parete. Il camino estetico, disponibile come accessorio, è posizionabile esclusivamente sopra la cappa a destra oppure a sinistra.

The timeless design of Ikona Maxxi Pure perfectly adapts to any open space area. The product is available in soft black matt or stainless steel finishes. It can be installed in a recirculating or duct-out version, suspended or wall-mounted. The attractive flue, available as an accessory, can be positioned exclusively above the hood on the right or left.





# NUAGE

DESIGN FABRIZIO CRISÀ





# NUAGE

DESIGN FABRIZIO CRISÀ



reddot award 2016  
winner



75 cm

**Filtrante** Filtering

**Acciaio inox rivestibile con cartongesso (non incluso), acciaio inox + bianco verniciabile** Coverable stainless steel finish with drywall (not included), stainless steel + paintable white



BACK ASPIRATION



LONG LIFE FILTER



TOTAL INTEGRATION



CM 50



CM 65



0150



ENERGY CLASS (A+++/D)

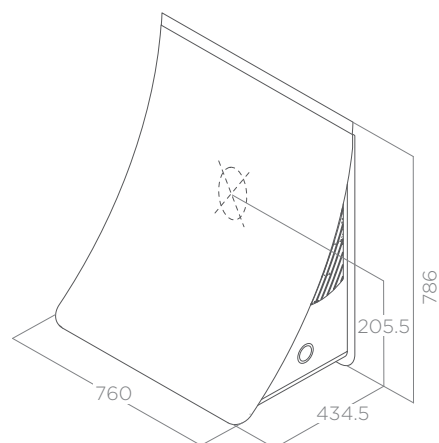

Modello unico e personalizzabile secondo le esigenze del cliente. Due sono le versioni disponibili: rivestibile con cartongesso (spessore di 6 mm, non compreso nella confezione) o metallo bianco verniciabile. Le immagini presentate sono esempi di estetiche esclusivamente dimostrative.

A unique model that can be personalised to suit customer needs. It is available in two versions: ready for finishing with gypsum panels (6 mm thick, not included in packaging) or in white metal ready for painting. The images shown are only an example of the possible solutions.

## ILLUMINAZIONE LIGHTING

Tipo Type	Strip Led 1x7 W
Intensità Intensity	141 LUX
Temperatura Temperature	3500 K

## PERFORMANCE PERFORMANCE

Comandi Controls	Rotativo elettronico 3V+I 3S+B Electronic rotative
Portata intensiva Booster airflow	580 m <sup>3</sup> /h
Livello sonoro min-max Noise level min-max	49 - 62 db(A)
Assorbimento totale Total absorption	227 W

**Filtro grassi alluminio incluso** Grease aluminium filter included  
**Filtro carbone incluso** Charcoal filter included

## ACCESSORI ACCESSORIES

Filtro carbone Charcoal filter	CFC0140343	46,00 €
Filtro carbone rigenerabile Regenerable charcoal filter	CFC0162221	104,00 €

## MODELLI MODELS

NUAGE DRYWALL/F/75	PRF0096484	1.173,00 €
NUAGE PAINTABLE/F/75	PRF0098374	1.268,00 €



YE

DESIGN FABRIZIO CRISÀ









# YE

DESIGN FABRIZIO CRISÀ



66x42 cm

Aspirante Duct-out

Cristalplant bianco White cristalplant



EASY TO  
MAINTAIN



LONG LIFE  
FILTER



SPECIAL  
MATERIAL



CM 50



CM 65



Ø150



ENERGY  
CLASS  
(A+/+/D)

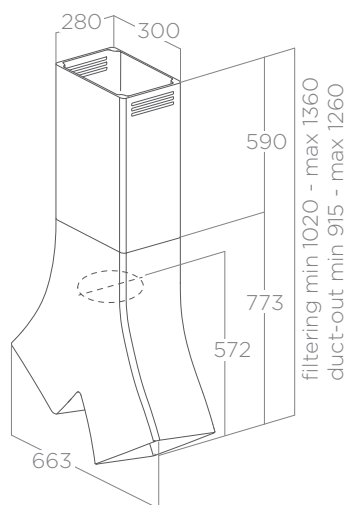

## ILLUMINAZIONE LIGHTING

Tipo Type	Led 2x4 W
Intensità Intensity	609 LUX
Temperatura Temperature	4000 K

## PERFORMANCE PERFORMANCE

Comandi Controls	Radiocomando 3V+I 3S+B Remote control
Portata intensiva Booster airflow	600 m <sup>3</sup> /h
Livello sonoro min-max Noise level min-max	45 - 61 db(A)
Assorbimento totale Total absorption	268 W

Filtro grassi alluminio incluso Grease aluminium filter included  
Radiocomando bianco incluso White remote control included

## ACCESSORI ACCESSORIES

Filtro carbone rigenerabile Regenerable charcoal filter	CFC0141737	119,00 €
Radiocomando bianco White remote control	KIT0121468	80,00 €
Radiocomando nero Black remote control	KIT0121469	80,00 €

## MODELLI MODELS

YE WH/A/66	PRF0098375	4.572,00 €
------------	------------	------------



Cristalplant®, materiale ipoallergenico e non tossico, resistente e piacevole al tatto. Grazie alla spugnetta abrasiva inclusa, ogni tipo di 'aggressione' superficiale può essere rimossa, mantenendo inalterato il suo aspetto nel tempo.

Cristalplant®, a hypoallergenic non-toxic material, resistant and agreeable to the touch. Thanks to the abrasive pad, any kind of surface damage can be easily removed while maintaining its original appearance over time.

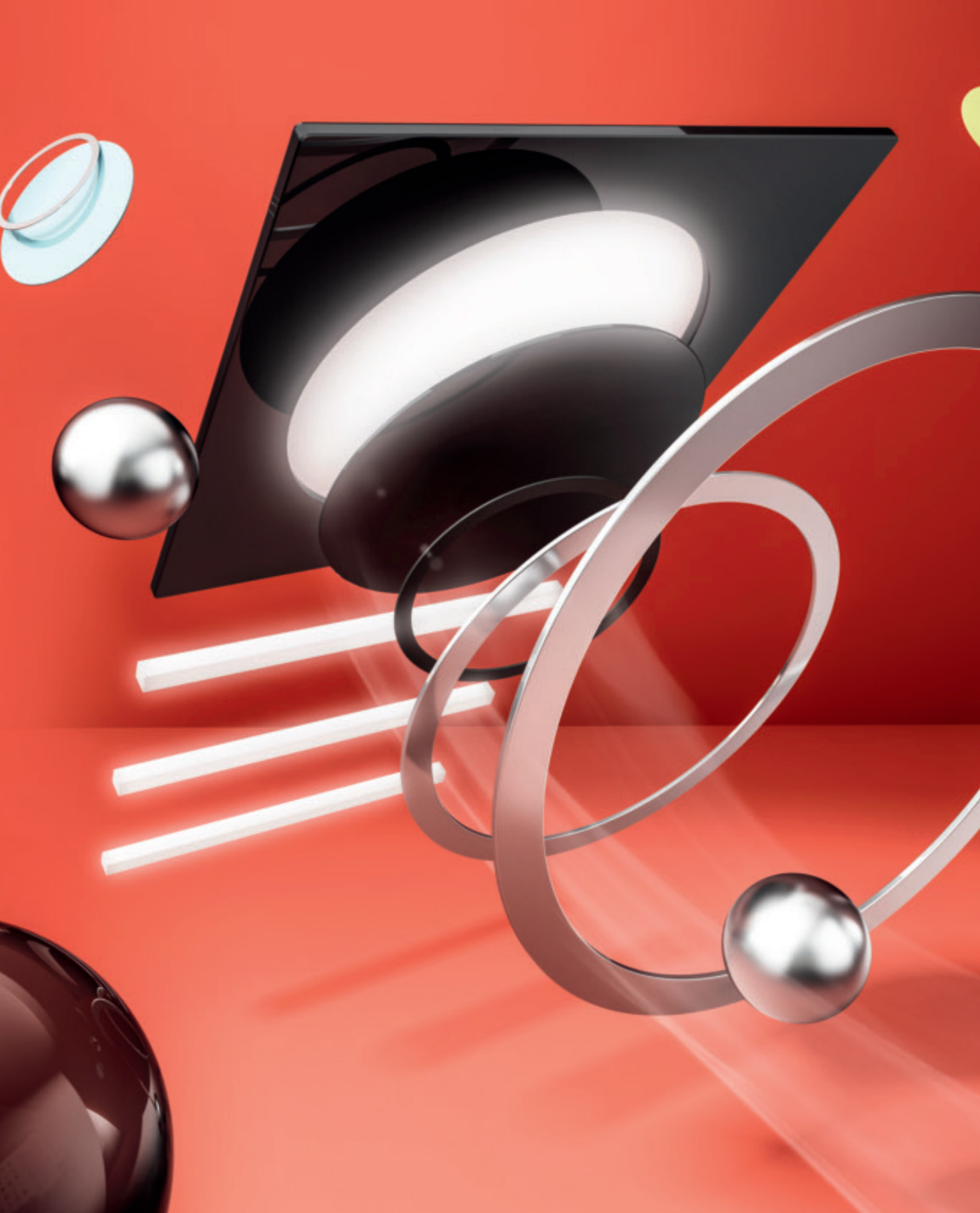

## WALL MOUNTED

Materiali eterogenei accostati tra loro per dar vita a cappe a parete dal potente cuore aspirante, nate per garantire un'aspirazione multidimensionale. Un design lineare, con fughe prospettiche che ne esaltano la verticalità, a richiamo della naturale ascensionalità dei fumi aspirati. Il legno, così come il gres, l'acciaio e il vetro nero, sono i materiali selezionati per realizzare questa gamma di cappe da vivere ogni giorno, belle e funzionali. Che emozionano.

A mixture of materials, placed alongside one other, to create wall-mounted hoods with a powerful extraction unit, designed to guarantee multidimensional extraction. A linear design, with vanishing points that enhance its verticality, drawing the eye up like the natural rise of the extracted fumes. Wood, like porcelain stoneware, steel and black glass, are materials that have been selected to create this attractive and functional range of hoods to enjoy every day. Conjuring up emotions.



# HAIKU

DESIGN FABRIZIO CRISÀ







# HAIKU

DESIGN FABRIZIO CRISÀ



32 - 60 - 90 - 120 cm

Aspirante Duct-out

Vetro nero, Krypton bianco, acciaio inox

Black glass, white Krypton, stainless steel



LONG LIFE  
FILTER



BACK  
ASPIRATION



COMFORT  
SILENCE



SPECIAL  
MATERIAL



CM 50



CM 65



Ø150



ENERGY  
CLASS  
(A+++/D)

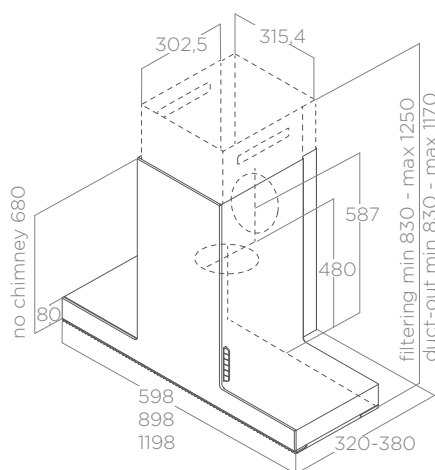
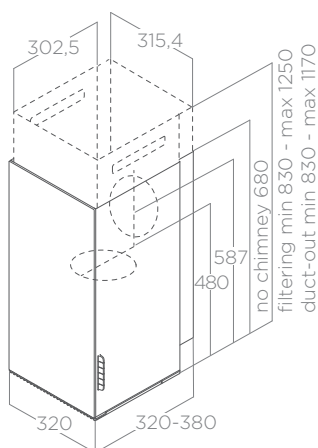

Possibilità di installazione, in modalità aspirante o filtrante, senza ausilio del camino superiore, restando in un'altezza di 680 mm  
Possibility for installation in extraction or filtration mode, without the aid of the upper chimney, remaining within a height of 680 mm

## ILLUMINAZIONE LIGHTING

Tipo Type	Strip Led 1x7 W
Intensità Intensity	253 LUX
Temperatura Temperature	3500 K

## PERFORMANCE PERFORMANCE

Comandi Controls	Pulsantiera elettronica 3V+2I 3S+2B Electronic push button
Portata intensiva Booster airflow	690 m <sup>3</sup> /h
Livello sonoro min-max Noise level min-max	34 - 51 db(A)
Assorbimento totale Total absorption	277 W

Filtro grassi alluminio incluso Grease aluminium filter included  
Camino incluso Chimney included

## ACCESSORI ACCESSORIES

Filtro carbone Charcoal filter	CFC0141529A	35,00 €
Filtro carbone rigenerabile Regenerable charcoal filter	CFC0141725A	78,00 €

## MODELLI MODELS

HAIKU IX/A/32	PRF0146254	874,00 €
HAIKU IX/A/60	PRF0146255	986,00 €
HAIKU IX/A/90	PRF0146256	1.095,00 €
HAIKU IX/A/120	PRF0146257	1.203,00 €
HAIKU BL/A/32	PRF0146263	1.148,00 €
HAIKU BL/A/60	PRF0146264	1.256,00 €
HAIKU BL/A/90	PRF0146265	1.369,00 €
HAIKU BL/A/120	PRF0146266	1.477,00 €
HAIKU WH/A/32	PRF0146267	1.148,00 €
HAIKU WH/A/60	PRF0146268	1.256,00 €
HAIKU WH/A/90	PRF0146269	1.369,00 €
HAIKU WH/A/120	PRF0146270	1.477,00 €

## Armonia e semplicità Harmony and simplicity

La linearità estetica prende forma nelle griglie in alluminio effetto ghisa che caratterizzano fortemente il prodotto. Sono facili da rimuovere e dotate di un sistema di bloccaggio ideato per evitare ogni possibile caduta accidentale.

La proposta dei materiali e delle superfici continue permettono una pulizia veloce ma efficace, anche dopo le cotture più ricche.

The aesthetic linearity can be seen in the cast iron effect aluminium grilles, which strongly characterise the product. They are easy to remove and are equipped with a blocking system designed to avoid accidental falls. The proposed materials and continuous surfaces allow fast and efficient cleaning, even after more intense cooking sessions.



## Visioni metriche Metric visions

Haiku, grazie alla varietà di dimensioni proposte, è perfetta per diverse soluzioni progettuali.

È disponibile sia nella versione a parete (32, 60, 90 e 120cm) che a isola (32, 120, 180cm), nelle modalità aspirante e filtrante.

Thanks to the sizes in which it is proposed, Haiku is perfect for a range of design solutions. It is available in both a wall-mounted version (32, 60, 90 and 120 cm) and island version (32, 120, 180 cm), in both an extractor and filtration version.



## Shift 3238 system - l'unico sistema a profondità regolabile Shift 3238 system - the only system with adjustable depth

Elica, per prima sul mercato, propone per Haiku SHIFT 3238 un sistema innovativo di staffe a muro, grazie al quale le operazioni di installazione si semplificano. Sarà possibile scegliere la posizione di Haiku per averla in linea con i pensili o per aumentare lo spazio di azione sul piano cottura.

SHIFT 3238 permette al corpo cappa di regolare millimetricamente la sua profondità. I vincoli semplicemente spariscono e si moltiplicano le soluzioni estetiche e i vantaggi nelle operazioni di pulizia.



Elica was the first in the market to propose an innovative wall-mounted bracket system in Haiku SHIFT 3238, thanks to which installation operations have been largely simplified. Haiku can be positioned either in line with the shelves or in such a way as to increase the work space on the hob.

SHIFT 3238 allows the millimetric adjustment of the hood body depth. Limitations simply disappear and aesthetic solutions multiply, as do the advantages of cleaning operations.

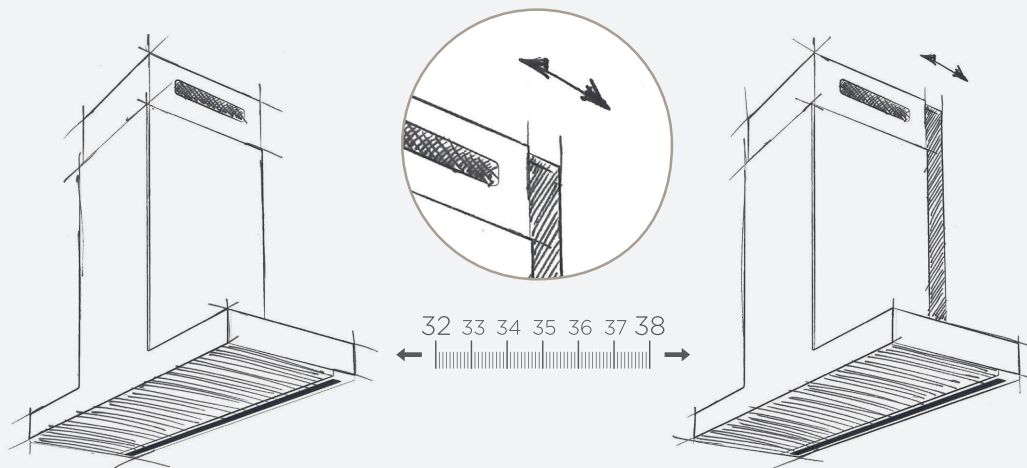

# BIO

DESIGN FABRIZIO CRISÀ









# BIO

DESIGN FABRIZIO CRISÀ



reddot award 2017  
winner



90 cm

Aspirante Duct-out

Rovere naturale + bianco effetto soft touch

Natural oak + white soft touch effect



SPECIAL  
MATERIAL



LONG LIFE  
FILTER ++



COMFORT  
SILENCE



TUNE  
WHITE



CM 50



CM 65



Ø150



ENERGY  
CLASS  
(A<sup>+</sup>/D)

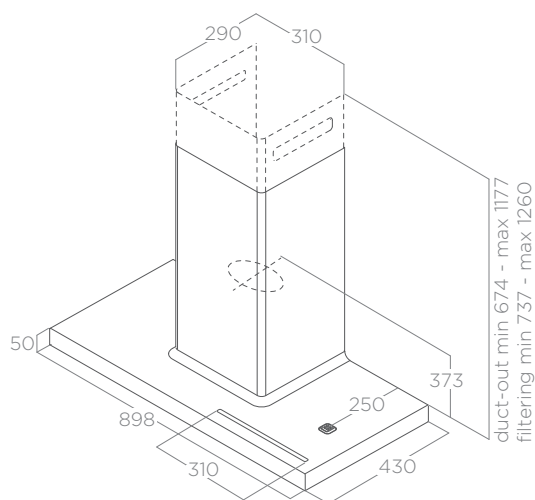

Possibilità di installazione, in modalità aspirante o filtrante, senza ausilio del camino superiore, restando in un'altezza di 678 mm  
Possibility for installation in extraction or filtration mode, without the aid of the upper chimney, remaining within a height of 678 mm

## ILLUMINAZIONE LIGHTING

Tipo Type	Strip Led 1x7 W
Intensità Intensity	141 LUX
Temperatura Temperature	2700 - 6500 K

## PERFORMANCE PERFORMANCE

Comandi Controls	Pulsantiera elettronica 3V+2I 3S+2B Electronic push button
Portata intensiva Booster airflow	757 m <sup>3</sup> /h
Livello sonoro min-max Noise level min-max	32 - 60 db(A)
Assorbimento totale Total absorption	317 W

Filtro grassi alluminio incluso Grease aluminium filter included  
Camino incluso Chimney included

## ACCESSORI ACCESSORIES

Filtro carbone rigenerabile Regenerable charcoal filter	CFC0141725A	78,00 €
Kit prima installazione filtrante HP First installation HP filtering kit	KIT0160440	315,00 €
Filtro carbone rigenerabile HP Regenerable charcoal HP filter	CFC0140091	290,00 €
Kit mensola muro rovere 60cm Oak wall shelf kit 60cm	KIT0120946	293,00 €
Radiocomando bianco White remote control	KIT0121468	80,00 €
Radiocomando nero Black remote control	KIT0121469	80,00 €

## MODELLI MODELS

BIO WH/A 90 ROVERE	PRF0147266	1.536,00 €
--------------------	------------	------------





# METEORITE

DESIGN FABRIZIO CRISÀ

90 - 120 cm

Aspirante Duct-out

Acciaio inox + vetro nero

Stainless steel + black glass



EASY TO  
MAINTAIN



MULTI-D  
CAPTURE



LONG LIFE  
FILTER ++



COMFORT  
SILENCE



TUNE WHITE



CM 50



CM 65



Ø150



ENERGY  
CLASS  
(A<sup>++</sup>/D)

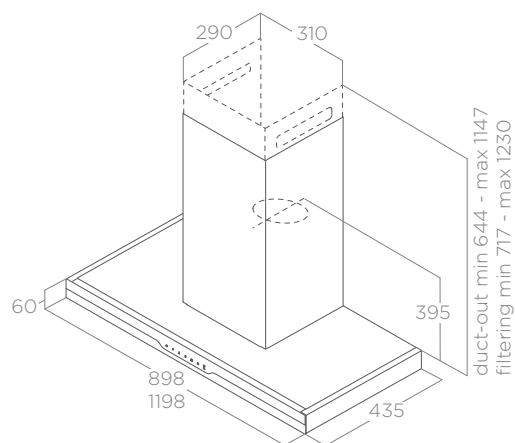

## ILLUMINAZIONE LIGHTING

Tipo Type	Strip Led 1x7 W
Intensità Intensity	141 LUX
Temperatura Temperature	2700 - 6500 K

## PERFORMANCE PERFORMANCE

Comandi Controls	Touch control capacitivo 3V+2I 3S+2B Capacitive touch control
Portata intensiva Booster airflow	800 m <sup>3</sup> /h
Livello sonoro min-max Noise level min-max	31 - 60 db(A)
Assorbimento totale Total absorption	317 W

Filtro grassi alluminio incluso Grease aluminium filter included  
Camino incluso Chimney included

## ACCESSORI ACCESSORIES

Kit prima installazione filtrante HP First installation HP filtering kit	KIT0160440	315,00 €
Filtro carbone rigenerabile Regenerable charcoal filter	CFC0141725A	78,00 €
Filtro carbone rigenerabile HP Regenerable charcoal filter HP	CFC0140091	290,00 €

## MODELLI MODELS

METEORITE IX/A/90	PRF0147272	1.422,00 €
METEORITE IX/A/120	PRF0147273	1.592,00 €

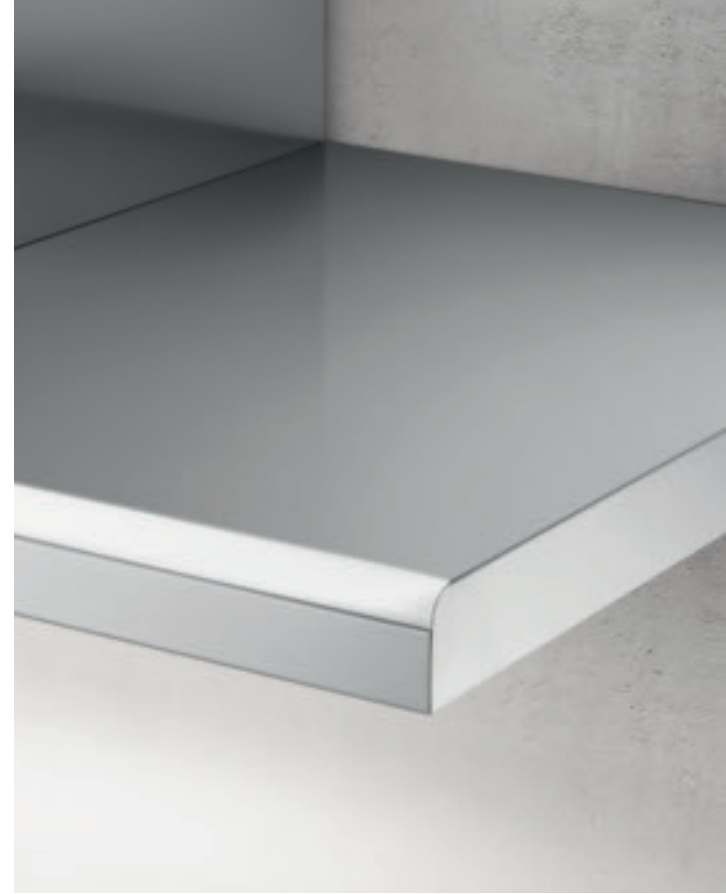





# MOON

ELICA DESIGN CENTER

60 - 90 - 120 cm

Filtrante Filtering

Acciaio inox Stainless steel



LONG LIFE  
FILTER



CM 50



CM 65



Ø150



ENERGY  
CLASS  
(A+++/D)

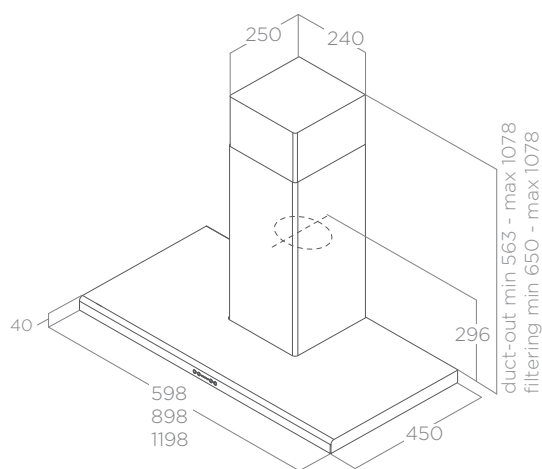

## ILLUMINAZIONE LIGHTING

Tipo Type	Neon 1x14 W (60cm) - Neon 1x21 W (90cm) - Neon 1x28 W (120cm)
Intensità Intensity	113 (60cm) - 170 (90cm) - 115 (120cm) LUX
Temperatura Temperature	6500 K

## PERFORMANCE PERFORMANCE

Comandi Controls	Pulsantiera elettronica 3V+I 3S+B Electronic push button
Portata intensiva Booster airflow	690 m <sup>3</sup> /h
Livello sonoro min-max Noise level min-max	52 - 68 db(A)
Assorbimento totale Total absorption	274 W (60cm) - 281 W (90cm) - 288 W (120cm)

Filtro grassi alluminio incluso Grease aluminium Filter included

Filtro carbone incluso Charcoal filter included

Camino incluso Chimney included

## ACCESSORI ACCESSORIES

Filtro carbone Charcoal filter	CFC0141529A	35,00 €
Filtro carbone rigenerabile Regenerable charcoal filter	CFC0141725A	78,00 €

## MODELLI MODELS

MOON IX/F/60	PRF0091764A	903,00 €
MOON IX/F/90	PRF0079550A	954,00 €
MOON IX/F/120	PRF0079551A	1.076,00 €





SWEET

DESIGN FABRIZIO CRISÀ



SWEET PELTROX



SWEET WHITE



SWEET IVORY



SWEET UMBER



SWEET COPPER



SWEET CAST IRON



# SWEET

DESIGN FABRIZIO CRISÀ



85 cm

Aspirante, Filtrante Duct-out, Filtering

Verniciature: bianco opaco, tortora opaco, avorio, rame opaco, peltrox, ghisa  
Painted: matt white, matt umber, ivory, matt copper, peltrox, cast iron



MULTI-D  
CAPTURE



LONG LIFE  
FILTER



BACK  
ASPIRATION



SPECIAL  
MATERIAL



CM 60



CM 70



Ø150



ENERGY  
CLASS  
(A<sup>++</sup>/D)

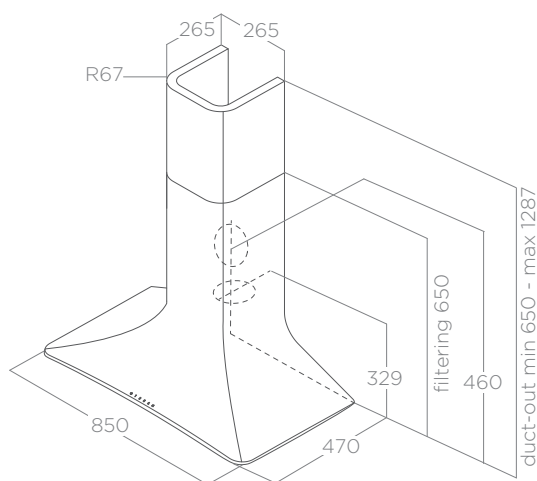

L'utilizzo del tecnopolimero permette di ottenere le linee morbide e caratterizzanti del design di Sweet. Disponibile sia in versione filtrante senza estensione camino che in versione aspirante con kit camino prolunga compreso nell'imballo.

The use of engineering plastics makes it possible to create the soft contours typical of the Sweet design. Available in both a filtration version without flue extension and extraction version with flue extension kit included in the packaging.

## ILLUMINAZIONE LIGHTING

Tipo Type	Strip Led 1x7 W
Intensità Intensity	197 LUX
Temperatura Temperature	4000 K

## PERFORMANCE PERFORMANCE

Comandi Controls	Touch control infrarossi 3V+I 3S+B Infrared touch control
Portata intensiva Booster airflow	580 m <sup>3</sup> /h
Livello sonoro min-max Noise level min-max	46 - 61 db(A)
Assorbimento totale Total absorption	207 W

Filtro grassi alluminio incluso Grease aluminium filter included

Filtro carbone rigenerabile incluso (\*) Regenerable charcoal filter included (\*)

Estensione camino incluso (Aspirante) Extension chimney included (Duct-out)

## ACCESSORI ACCESSORIES

Filtro carbone rigenerabile Regenerable charcoal filter	CFC0140426	85,00 €
--	------------	---------

## MODELLI MODELS

SWEET WHITE/A/85+CAM	PRF0167320	1.028,00 €
SWEET WHITE F/85 (*)	PRF0043030A	881,00 €
SWEET UMBER/A/85+CAM	PRF0167321	1.028,00 €
SWEET UMBER F/85 (*)	PRF0043031A	881,00 €
SWEET IVORY/A/85+CAM	PRF0167322	1.028,00 €
SWEET IVORY F/85 (*)	PRF0043033A	881,00 €
SWEET COPPER/A/85+CAM	PRF0167324	1.115,00 €
SWEET COPPER/F/85 (*)	PRF0120672A	956,00 €
SWEET PELTROX/A/85+CAM	PRF0167323	1.115,00 €
SWEET PELTROX/F/85 (*)	PRF0120689A	956,00 €
SWEET CAST IRON/A/85+CAM	PRF0167319	1.028,00 €
SWEET CAST IRON/F/85 (*)	PRF0120702A	881,00 €



ADÉLE  
DESIGN FABRIZIO CRISÀ





ADÉLE BLIX



ADÉLE BL MAT





# ADÉLE

DESIGN FABRIZIO CRISÀ

60 - 90 cm

Aspirante Duct-out

Acciaio inox + vetro nero, nero effetto soft touch + vetro nero

Stainless steel + black glass, black soft touch effect + black glass



LONG LIFE  
FILTER



CM 50



CM 65



Ø150



ENERGY  
CLASS  
(A\*\*/D)

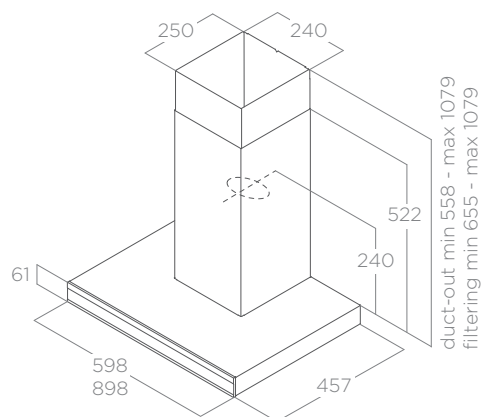

## ILLUMINAZIONE LIGHTING

Tipo Type	STRIP LED 1x7 W
Intensità Intensity	421 LUX
Temperatura Temperature	3000 K

## PERFORMANCE PERFORMANCE

Comandi Controls	Touch control capacitivo 3V+I 3S+B Capacitive touch control
Portata intensiva Booster airflow	770 m <sup>3</sup> /h
Livello sonoro min-max Noise level min-max	55 - 69 db(A)
Assorbimento totale Total absorption	277 W

Filtro grassi alluminio incluso Grease aluminium filter included  
Camino incluso Chimney included

## ACCESSORI ACCESSORIES

Filtro carbone Charcoal filter	CFC0141529A	35,00 €
Filtro carbone rigenerabile Regenerable charcoal filter	CFC0141725A	78,00 €
Kit prolunga camino acciaio inox H81 Stainless steel chimney extension kit H81	KIT00780	96,00 €

## MODELLI MODELS

ADÉLE BLIX/A/60	PRF0167314	536,00 €
ADÉLE BLIX/A/90	PRF0167315	578,00 €
ADÉLE BL MAT/A/60	PRF0167318	536,00 €
ADÉLE BL MAT/A/90	PRF0167317	578,00 €

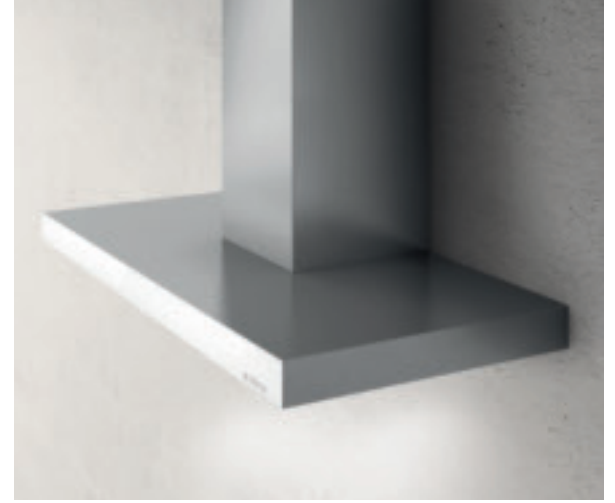

# JOY

ELICA DESIGN CENTER

60 - 90 cm

Aspirante Duct-out

Acciaio inox + vetro bianco, acciaio inox + vetro nero

Stainless steel + white glass, stainless steel + black glass



LONG LIFE  
FILTER



CM 50



CM 65



Ø150



ENERGY  
CLASS  
(A++/D)

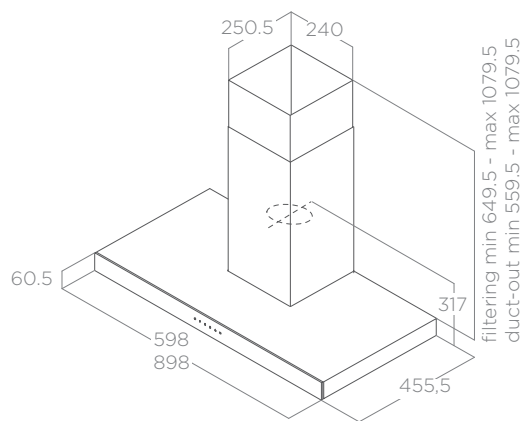

ILLUMINAZIONE LIGHTING	
Tipo Type	Led 2x2,5 W
Intensità Intensity	381 LUX
Temperatura Temperature	3500 K

PERFORMANCE PERFORMANCE	
Comandi Controls	Touch control capacitivo 3V+I 3S+B Capacitive touch control
Portata intensiva Booster airflow	713 m <sup>3</sup> /h
Livello sonoro min-max Noise level min-max	51 - 69 db(A)
Assorbimento totale Total absorption	265 W

**Filtro grassi alluminio incluso** Grease aluminium filter included  
**Camino incluso** Chimney included

ACCESSORI ACCESSORIES		
Filtro carbone Charcoal filter	CFC0141529A	35,00 €
Filtro carbone rigenerabile Regenerable charcoal filter	CFC0141725A	78,00 €
Kit prolunga camino acciaio inox H81 Stainless steel chimney extension kit H81	KIT00780	96,00 €

MODELLI MODELS		
JOY BLIX/A/60	PRF0104625A	510,00 €
JOY BLIX/A/90	PRF0104626A	542,00 €
JOY WHIX/A/60	PRF0104630A	510,00 €
JOY WHIX/A/90	PRF0104631A	542,00 €



# GALAXY

ELICA DESIGN CENTER

80 cm

Aspirante Duct-out

Acciaio inox + vetro nero, acciaio inox + vetro bianco

Stainless steel + black glass, stainless steel + white glass



LONG LIFE  
FILTER



CM 50



CM 65



Ø150



ENERGY  
CLASS  
(A<sup>+</sup>/D)

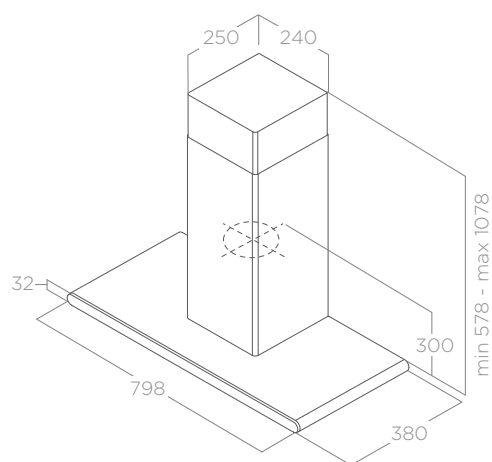

## ILLUMINAZIONE LIGHTING

Tipo Type	Led 2x2,5 W
Intensità Intensity	145 LUX
Temperatura Temperature	3500 K

## PERFORMANCE PERFORMANCE

Comandi Controls	Touch control capacitivo 3V+I 3S+B Capacitive touch control
Portata intensiva Booster airflow	647 m <sup>3</sup> /h
Livello sonoro min-max Noise level min-max	52 - 69 db(A)
Assorbimento totale Total absorption	265 W

Filtro grassi alluminio incluso Grease aluminium filter included  
Camino incluso Chimney included

## ACCESSORI ACCESSORIES

Filtro carbone Charcoal filter	CFC0141529A	35,00 €
Filtro carbone rigenerabile Regenerable charcoal filter	CFC0141725A	78,00 €

## MODELLI MODELS

GALAXY BLIX/A/80	PRF0008948B	580,00 €
GALAXY WHIX/A/80	PRF0009822B	580,00 €



# THIN

DESIGN FABRIZIO CRISÀ

60 - 90 - 120 cm

Aspirante Duct-out

Acciaio inox Stainless steel



LONG LIFE  
FILTER



COMFORT  
SILENCE



BACK  
ASPIRATION



CM 50



CM 65



Ø150



ENERGY  
CLASS  
(A++/D)

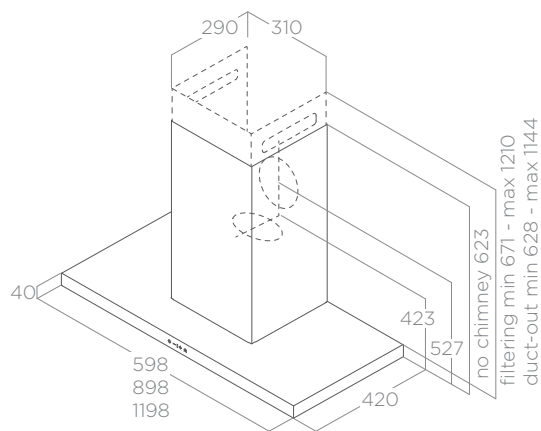

## ILLUMINAZIONE LIGHTING

Tipo Type	Strip Led 1x7 W
Intensità Intensity	477 LUX
Temperatura Temperature	3500 K

## PERFORMANCE PERFORMANCE

Comandi Controls	Touch control infrarossi 3V+2I 3S+2B Infrared touch control
Portata intensiva Booster airflow	680 m <sup>3</sup> /h
Livello sonoro min-max Noise level min-max	34 - 52 db(A)
Assorbimento totale Total absorption	277 W

Filtro grassi alluminio incluso Grease aluminium filter included  
Camino incluso Chimney included

## ACCESSORI ACCESSORIES

Filtro carbone Charcoal filter	CFC0141529A	35,00 €
Filtro carbone rigenerabile Regenerable charcoal filter	CFC0141725A	78,00 €

## MODELLI MODELS

THIN IX/A/60	PRF0144970	658,00 €
THIN IX/A/90	PRF0144969	729,00 €
THIN IX/A/120	PRF0144972	802,00 €



# LOL

ELICA DESIGN CENTER

60 - 90 cm

Aspirante Duct-out

Nero gofrato, acciaio inox

Embossed black, stainless steel



LONG LIFE  
FILTER



CM 50



CM 65



Ø150



ENERGY  
CLASS  
(A++/D)

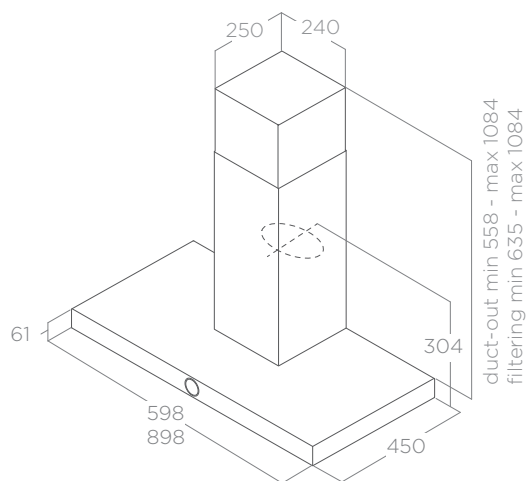

ILLUMINAZIONE LIGHTING	
Tipo Type	Led 2x2,5 W
Intensità Intensity	381 LUX
Temperatura Temperature	3500 K

PERFORMANCE PERFORMANCE	
Comandi Controls	Rotativo elettronico 3V+I 3S+B Electronic rotative
Portata intensiva Booster airflow	680 m <sup>3</sup> /h
Livello sonoro min-max Noise level min-max	52 - 67 db(A)
Assorbimento totale Total absorption	255 W

Filtro grassi alluminio incluso Grease aluminium filter included  
Camino incluso Chimney included

ACCESSORI ACCESSORIES		
Filtro carbone Charcoal filter	CFC0141529A	35,00 €
Filtro carbone rigenerabile Regenerable charcoal filter	CFC0141725A	78,00 €
Kit prolunga camino acciaio inox H81 Stainless steel chimney extension kit H81	KIT00780	96,00 €

MODELLI MODELS		
LOL IX/A/60	PRF0097149A	553,00 €
LOL IX/A/90	PRF0097323A	587,00 €
LOL BL/A/60	PRF0097782A	541,00 €
LOL BL/A/90	PRF0097906A	577,00 €



# SPOT PLUS

DESIGN FABRIZIO CRISÀ

60 - 90 - 120 cm

Aspirante Duct-out

Acciaio inox Stainless steel



LONG LIFE  
FILTER



CM 50



CM 65



Ø150



ENERGY  
CLASS  
(A+++D)

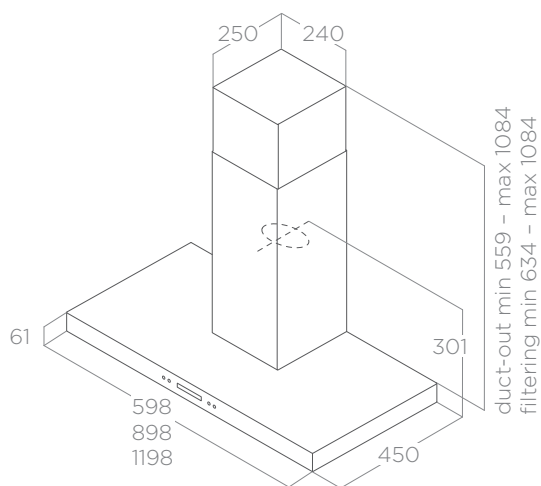

## ILLUMINAZIONE LIGHTING

Tipo Type	Led 2x2,5 W
Intensità Intensity	381 LUX
Temperatura Temperature	3500 K

## PERFORMANCE PERFORMANCE

Comandi Controls	Pulsantiera elettronica con LCD 3V+I 3S+B Electronic push button with LCD
Portata intensiva Booster airflow	620 m <sup>3</sup> /h
Livello sonoro min-max Noise level min-max	52 - 67 db(A)
Assorbimento totale Total absorption	205 W

Filtro grassi alluminio incluso Grease aluminium filter included  
Camino incluso Chimney included

## ACCESSORI ACCESSORIES

Filtro carbone Charcoal filter	CFC0141529A	35,00 €
Filtro carbone rigenerabile Regenerable charcoal filter	CFC0141725A	78,00 €
Kit prolunga camino acciaio inox H81 Stainless steel chimney extension kit H81	KIT00780	96,00 €

## MODELLI MODELS

SPOT PLUS IX/A/60	PRF0097374A	513,00 €
SPOT PLUS IX/A/90	PRF0097373A	530,00 €
SPOT PLUS IX/A/120	PRF0100242A	626,00 €



## SPOT URBAN

ELICA DESIGN CENTER

90 cm

Aspirante Duct-out

Metallo effetto ghisa, metallo effetto zinco

Cast iron effect metal, zinc coating effect metal



LONG LIFE  
FILTER



SPECIAL  
MATERIAL



CM 50



CM 65



Ø150



ENERGY  
CLASS  
(A++/D)

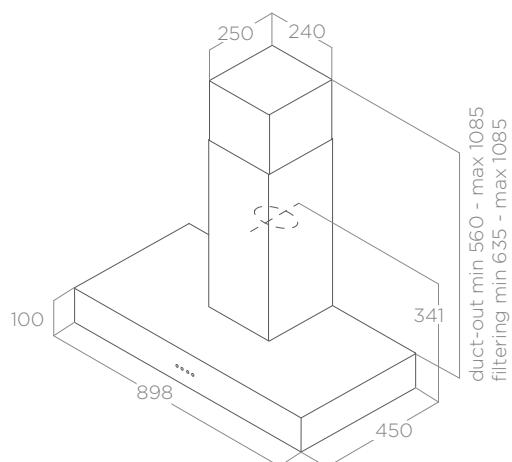

In linea con i nuovi trend delle cucine, che vede sempre più presente un design industrial e Urban, Elica ha ideato nuove combinazioni di finiture che permettono alla cappa di integrarsi perfettamente con questo stile.

In line with latest kitchen trends, where industrial and urban design is continuously gaining ground, Elica has developed new combinations of finishes allowing the hood to be perfectly integrated with this style.

### ILLUMINAZIONE LIGHTING

Tipo Type	Led 2x2,5 W
Intensità Intensity	381 LUX
Temperatura Temperature	3500 K

### PERFORMANCE PERFORMANCE

Comandi Controls	Pulsantiera meccanica 3V 3S Mechanical push button
Portata massima Max airflow	630 m <sup>3</sup> /h
Livello sonoro min-max Noise level min-max	52 - 71 db(A)
Assorbimento totale Total absorption	255 W

Filtro grassi alluminio incluso Grease aluminium filter included  
Camino incluso Chimney included

### ACCESSORI ACCESSORIES

Filtro carbone Charcoal filter	CFC0141529A	35,00 €
Filtro carbone rigenerabile Regenerable charcoal filter	CFC0141725A	78,00 €

### MODELLI MODELS

SPOT URBAN CAST IRON/A/90	PRF0147736	488,00 €
SPOT URBAN ZINC/A/90	PRF0147737	488,00 €



## SPOT NG

ELICA DESIGN CENTER

60 - 90 - 120 cm (H6 - H10)

Aspirante Duct-out

Acciaio inox Stainless steel



LONG LIFE  
FILTER



CM 50



CM 65



Ø150



ENERGY  
CLASS  
(A+++D)

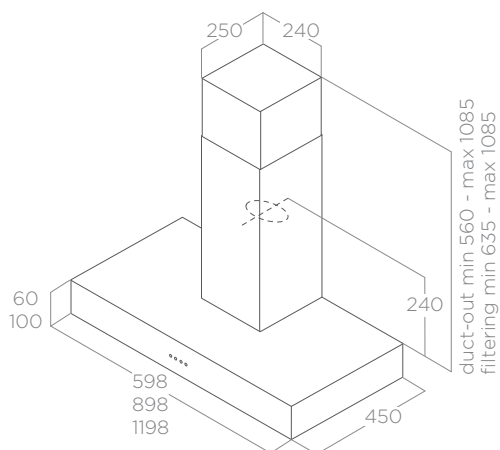

### ILLUMINAZIONE LIGHTING

Tipo Type	Led 2x2,5 W (60cm,90cm) - Led 3x2,5 W (120cm)
Intensità Intensity	381 (60cm,90cm) - 571 LUX (120cm)
Temperatura Temperature	3500 K

### PERFORMANCE PERFORMANCE

Comandi Controls	Pulsantiera meccanica 3V 3S Mechanical push button
Portata massima Max airflow	368 m <sup>3</sup> /h
Livello sonoro min-max Noise level min-max	55 - 62 db(A)
Absorbimento totale Total absorption	140 W (60cm,90cm) - 142.5 W (120cm)

Filtro grassi alluminio incluso Grease aluminium filter included  
Camino incluso Chimney included

### ACCESSORI ACCESSORIES

Filtro carbone Charcoal filter	CFC0141529A	35,00 €
Filtro carbone rigenerabile Regenerable charcoal filter	CFC0141725A	78,00 €
Kit prolunga camino acciaio inox H81 Stainless steel chimney extension kit H81	KIT00780	96,00 €

### MODELLI MODELS

SPOT NG H10 IX/A/60	55916386A	396,00 €
SPOT NG H10 IX/A/90	55916387A	412,00 €
SPOT NG H10 IX/A/120	PRF0099408A	494,00 €
SPOT NG H6 IX/A/60	55916388A	396,00 €
SPOT NG H6 IX/A/90	55916389A	412,00 €
SPOT NG H6 IX/A/120	PRF0099407A	494,00 €





# CRUISE

ELICA DESIGN CENTER

60 - 90 cm

Aspirante Duct-out

Acciaio inox Stainless steel



LONG LIFE  
FILTER



CM 50



CM 65



Ø150



ENERGY  
CLASS  
(A++/D)

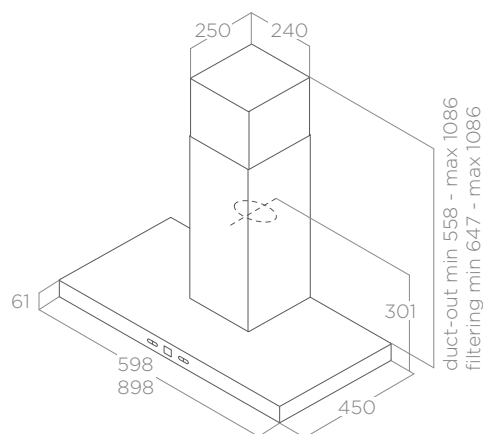

ILLUMINAZIONE LIGHTING	
Tipo Type	Led 2x2,5 W
Intensità Intensity	145 LUX
Temperatura Temperature	3500 K

PERFORMANCE PERFORMANCE	
Comandi Controls	Pulsantiera elettronica con display 3V+I 3S+B Electronic push button with display
Portata intensiva Booster airflow	713 m <sup>3</sup> /h
Livello sonoro min-max Noise level min-max	51 - 69 db(A)
Assorbimento totale Total absorption	265 W

**Filtro grassi alluminio incluso** Grease aluminium filter included  
**Camino incluso** Chimney included

ACCESSORI ACCESSORIES		
Filtro carbone Charcoal filter	CFC0141529A	35,00 €
Filtro carbone rigenerabile Regenerable charcoal filter	CFC0141725A	78,00 €
Kit prolunga camino acciaio inox H81 Stainless steel chimney extension kit H81	KIT00780	96,00 €

MODELLI MODELS		
CRUISE IX/A/60	PRF0147062	424,00 €
CRUISE IX/A/90	PRF0147074	445,00 €



# TRIBE

ELICA DESIGN CENTER

60 - 90 cm

Aspirante Duct-out

Acciaio inox + vetro

Stainless steel + glass



LONG LIFE  
FILTER



CM 50



CM 65



Ø150



ENERGY  
CLASS  
(A\*\*/D)

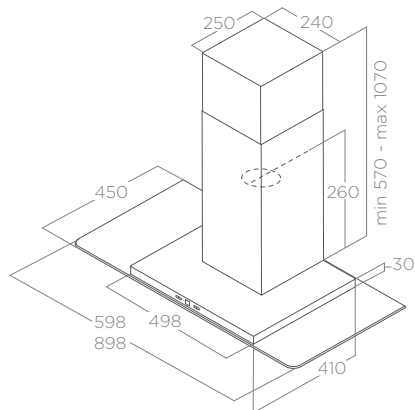

## ILLUMINAZIONE LIGHTING

Tipo Type	Led 2x2,5 W
Intensità Intensity	381 LUX
Temperatura Temperature	3000 K

## PERFORMANCE PERFORMANCE

Comandi Controls	Pulsantiera elettronica con display 3V+I 3S+B Electronic push button with display
Portata intensiva Booster airflow	600 m <sup>3</sup> /h
Livello sonoro min-max Noise level min-max	48 - 64 db(A)
Assorbimento totale Total absorption	205 W

Filtro grassi alluminio incluso Grease aluminium filter included  
Camino incluso Chimney included

## ACCESSORI ACCESSORIES

Filtro carbone Charcoal filter	CFC0141529A	35,00 €
Filtro carbone rigenerabile Regenerable charcoal filter	CFC0141725A	78,00 €
Kit prolunga camino acciaio inox H81 Stainless steel chimney extension kit H81	KIT00780	96,00 €

## MODELLI MODELS

TRIBE A IX/A/60	PRF0150292	525,00 €
TRIBE A IX/A/90	PRF0150291	537,00 €



## FLAT GLASS

ELICA DESIGN CENTER

60 - 90 cm

Aspirante Duct-out

Acciaio Inox + vetro

Stainless steel + glass



LONG LIFE  
FILTER



CM 50



CM 65



Ø150



ENERGY  
CLASS  
(A~D)

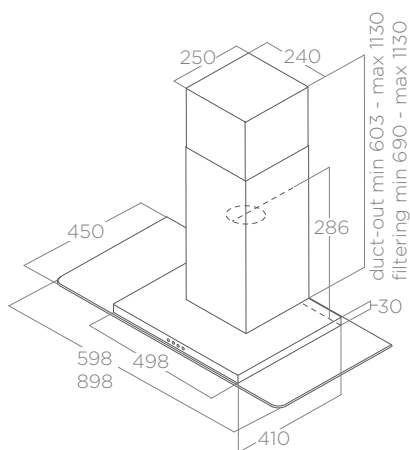

### ILLUMINAZIONE LIGHTING

Tipo Type	Led 2x2,5 W
Intensità Intensity	381 LUX
Temperatura Temperature	3500 K

### PERFORMANCE PERFORMANCE

Comandi Controls	Pulsantiera meccanica 3V 3S Mechanical push button
Portata massima Max airflow	368 m <sup>3</sup> /h
Livello sonoro min-max Noise level min-max	55 - 62 db(A)
Assorbimento totale Total absorption	140 W

Filtro grassi alluminio incluso Grease aluminium filter included  
Camino incluso Chimney included

### ACCESSORI ACCESSORIES

Filtro carbone Charcoal filter	CFC0141529A	35,00 €
Filtro carbone rigenerabile Regenerable charcoal filter	CFC0141725A	78,00 €
Kit prolunga camino acciaio inox H81 Stainless steel chimney extension kit H81	KIT00780	96,00 €

### MODELLI MODELS

FLAT GLASS IX/A/60	68516391A	482,00 €
FLAT GLASS IX/A/90	68516390A	482,00 €



# REEF

ELICA DESIGN CENTER

60 - 90 cm

Aspirante Duct-out

Acciaio inox + vetro

Stainless steel + glass



LONG LIFE  
FILTER



CM 50



CM 65



Ø150



ENERGY  
CLASS  
(A++-D)

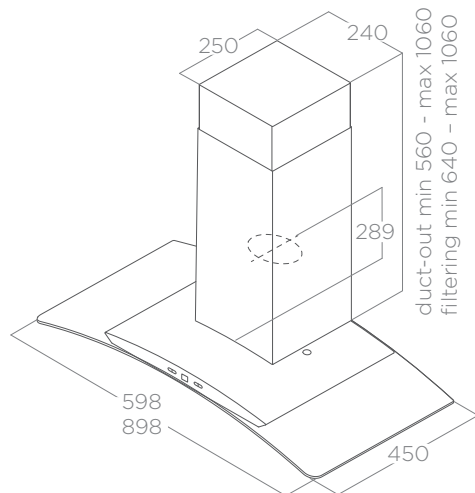

## ILLUMINAZIONE LIGHTING

Tipo Type	Led 2x2,5 W
Intensità Intensity	381 LUX
Temperatura Temperature	3000 K

## PERFORMANCE PERFORMANCE

Comandi Controls	Pulsantiera elettronica con display 3V+I 3S+B Electronic push button with display
Portata intensiva Booster airflow	600 m <sup>3</sup> /h
Livello sonoro min-max Noise level min-max	48 - 64 db(A)
Assorbimento totale Total absorption	205 W

**Filtro grassi alluminio incluso** Grease aluminium filter included  
**Camino incluso** Chimney included

## ACCESSORI ACCESSORIES

Filtro carbone Charcoal filter	CFC0141529A	35,00 €
Filtro carbone rigenerabile Regenerable charcoal filter	CFC0141725A	78,00 €
Kit prolunga camino acciaio inox H81 Stainless steel chimney extension kit H81	KIT00780	96,00 €

## MODELLI MODELS

REEF A IX/A/60	PRF0150289	525,00 €
REEF A IX/A/90	PRF0150288	542,00 €



# CIRCUS

ELICA DESIGN CENTER

60 - 90 cm

Aspirante Duct-out

Acciaio inox + vetro

Stainless steel + glass



LONG LIFE  
FILTER



CM 50



CM 65



Ø150



ENERGY  
CLASS  
(A++/D)

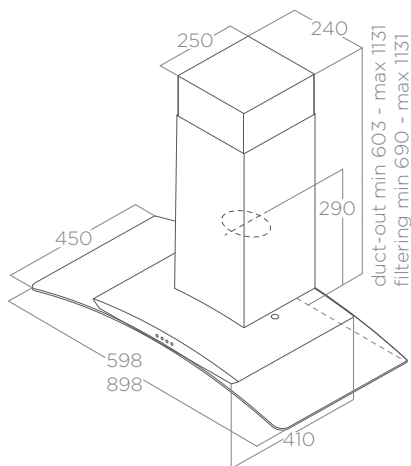

## ILLUMINAZIONE LIGHTING

Tipo Type	Led 2x2,5 W
Intensità Intensity	381 LUX
Temperatura Temperature	3500 K

## PERFORMANCE PERFORMANCE

Comandi Controls	Pulsantiera meccanica 3V 3S Mechanical push button
Portata massima Max airflow	368 m <sup>3</sup> /h
Livello sonoro min-max Noise level min-max	55 - 62 db(A)
Assorbimento totale Total absorption	140 W

Filtro grassi alluminio incluso Grease aluminium filter included  
Camino incluso Chimney included

## ACCESSORI ACCESSORIES

Filtro carbone Charcoal filter	CFC0141529A	35,00 €
Filtro carbone rigenerabile Regenerable charcoal filter	CFC0141725A	78,00 €
Kit prolunga camino acciaio inox H81 Stainless steel chimney extension kit H81	KIT00780	96,00 €

## MODELLI MODELS

CIRCUS IX/A/60	68116393A	494,00 €
CIRCUS IX/A/90	68116392A	494,00 €





# SUPER PLAT

DESIGN FABRIZIO CRISÀ



SUPER PLAT GR



SUPER PLAT BL

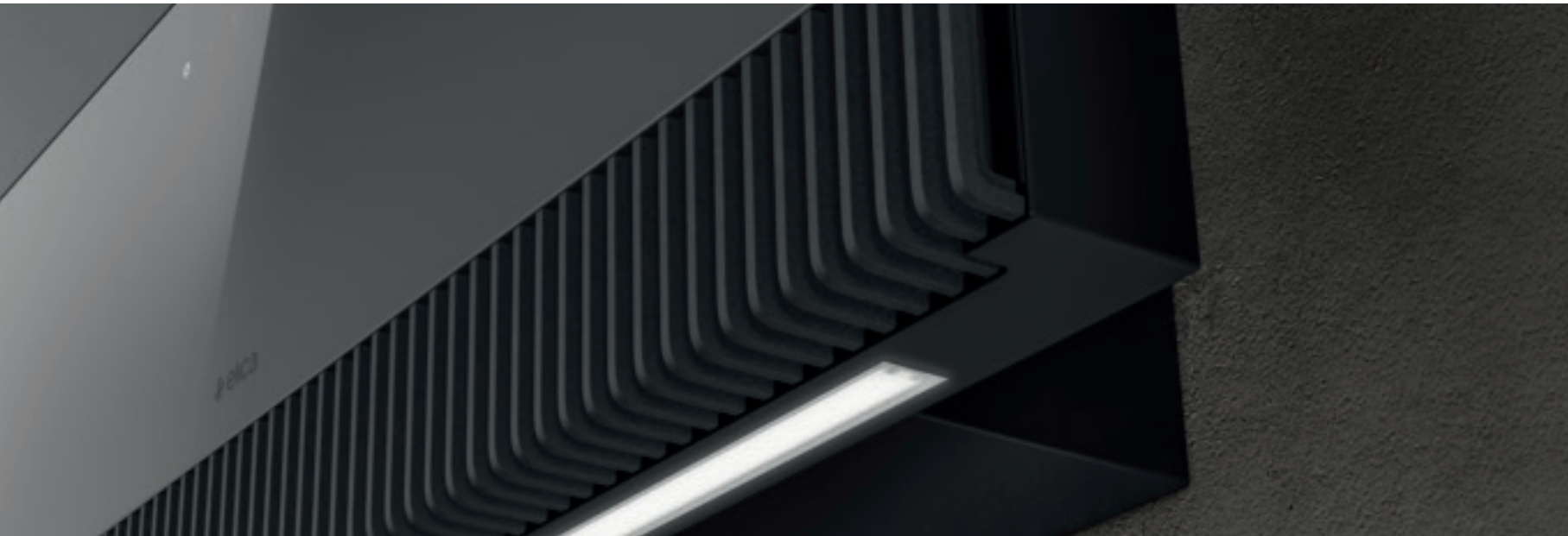





# SUPER PLAT

ELICA CONNECT

DESIGN FABRIZIO CRISÀ



reddot award 2021  
winner

80 cm

Filtrante Filtering

Vetro nero, vetro grigio + effetto ghisa

Black glass, grey glass + cast iron effect



EASY TO  
MAINTAIN



MULTI-D  
CAPTURE



CONNECTIVITY



LONG LIFE  
FILTER



COMFORT  
SILENCE



DIM LIGHT



CM 50



CM 65



Ø150



ENERGY  
CLASS  
(A++/D)

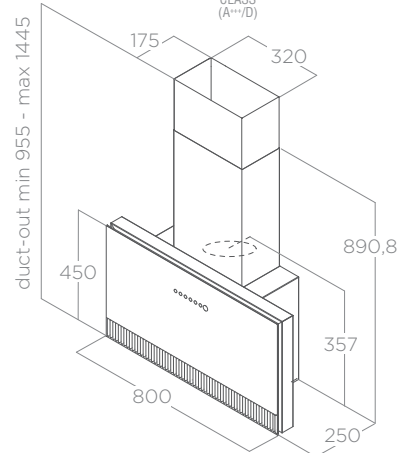

Super Plat consente all'utente di sentirsi più libero e di avere più tempo per concentrarsi sulle operazioni di cottura grazie al suo sistema wireless intelligente. La cappa può essere utilizzata tramite la app Elica Connect o uno smart speaker ricevendo e dando informazioni.

Super Plat heightens the user's sense of freedom, offering more time to concentrate on cooking thanks to the smart wireless system. The hood can be used either through the Elica Connect app or with a smart speaker, giving and receiving information.

## ILLUMINAZIONE LIGHTING

Tipo Type	Strip Led 1x7 W
Intensità Intensity	197 LUX
Temperatura Temperature	3500 K

## PERFORMANCE PERFORMANCE

Comandi Controls	Touch control capacitivo 3V+2I 3S+2B Capacitive touch control
Portata intensiva Booster airflow	740 m <sup>3</sup> /h
Livello sonoro min-max Noise level min-max	37 - 57 db(A)
Assorbimento totale Total absorption	277 W

Filtro grassi alluminio incluso Grease aluminium filter included

Filtro carbone rigenerabile incluso Regenerable charcoal filter included

## ACCESSORI ACCESSORIES

Filtro carbone rigenerabile (*) Regenerable charcoal filter (*)	CFC0140423	55,00 €
Kit camino acciaio inox Stainless steel chimney kit	KIT0171543	115,00 €
Kit camino nero Black chimney kit (*) ordinare 3 pezzi (*) order 3 pieces	KIT0166364	115,00 €

## MODELLI MODELS

SUPER PLAT BL/F/80	PRF0164980	1.208,00 €
SUPER PLAT GR/F/80	PRF0165017	1.208,00 €

## Combinazione unica di forme e materiali

### Unique combination of form and material

Il nuovo modello Super Plat è una cappa dalle linee semplici e moderne. Nasce dall'esigenza di chi predilige un elettrodomestico che, pur mantenendo la sua identità, si integra perfettamente allo stile della cucina in cui è inserita, senza provocare discontinuità di forma e superficie. Il suo design la rende perfetta sia nell'installazione stand-alone che inserita tra due pensili. Offre un'ampia flessibilità d'uso: nasce in versione filtrante e con l'aggiunta di camini estetici può essere facilmente trasformata in modalità aspirante. Super Plat è disponibile in vetro nero o vetro grigio, combinati con elementi effetto ghisa che la rendono protagonista in cucina.

The new Super Plat model is a hood characterised by simple and modern lines. It's a response to the demand for an electrical appliance, which, despite remaining true to its identity, perfectly blends into the style of the kitchen where it's installed, without interrupting the continuity of forms and surfaces. Its design makes it perfect for installation either as a stand-alone or between cabinets. It offers broad flexibility of use: it is originally a recirculating hood, but with the addition of stylish flues can easily be transformed into a duct-out version. Super Plat is available in black or grey glass, combined with cast iron effect elements to make it a genuine feature item in the kitchen.



## Connessione Wi-Fi

### Wi-Fi connection **ELICA CONNECT**

Grazie al suo modulo Wi-fi, Super Plat è sempre connessa ad un cloud a tua disposizione. Attraverso la app Elica Connect si possono controllare da remoto la velocità di aspirazione, tutte le funzionalità della luce e monitorare lo stato del prodotto. Con la app avrai accesso a strumenti che ti aiuteranno a mantenere pulito ed efficiente il tuo prodotto nel tempo. Inoltre, è possibile collegare Super Plat con gli smart speakers più diffusi per comandarla con la tua voce.

Thanks to its Wi-Fi module, Super Plat is always connected to a cloud at your service. Using the Elica Connect app, you can control the extraction speed, all light functions and even monitor the product's status. The app provides you with access to tools that help keep your product running clean and efficiently over time. What's more, Super Plat can be connected with the most popular smart speakers so you can control it with your own voice.

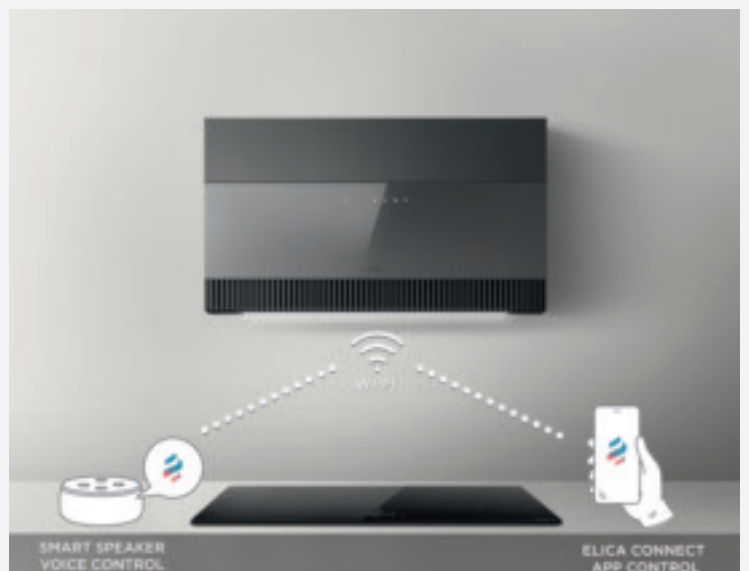

## Performance al top

### Top performance

Super Plat sfrutta la tecnologia Multi-d Capture di Elica: l'aspirazione non è più concentrata in una specifica zona ma distribuita su tutto il perimetro della superficie frontale. In questo modo la capacità di captazione raggiunge il massimo livello ed è in grado di garantire ottimi risultati nella pulizia dell'aria sia da vapori che da cattivi odori. Nonostante la potenza del suo motore, Super Plat resta molto silenziosa anche alla massima potenza grazie alla tecnologia Comfort Silence che consente una riduzione del rumore durante l'utilizzo della cappa in ogni situazione domestica.

Super Plat exploits Elica's Multi-d Capture technology: extraction is no longer concentrated in one specific zone but rather distributed across the entire perimeter of the front surface. As such, the extraction capacity reaches the highest levels and is able to guarantee excellent results in terms of clearing the air of unpleasant vapours and smells. Despite its powerful motor, Super Plat is extremely quiet even at the highest speed thanks to the Comfort Silence technology, which reduces the noise level during use of the hood in all household situations.



## Facile da pulire

### Easy to clean

Super Plat è stata progettata per permettere all'utente di eseguire le normali operazioni di manutenzione e pulizia in modo semplice, rapido e sicuro. L'assenza di parti meccaniche a vista per l'apertura del pannello frontale semplifica le operazioni di manutenzione: gli utenti hanno accesso diretto alla parte interna del prodotto e possono muoversi in libertà senza alcun ostacolo. Le griglie sono facilmente smontabili per essere completamente igienizzate.

Super Plat is designed to make standard cleaning and maintenance operations simpler, faster and safer for the user. The absence of any visible mechanical parts when the front panel is opened greatly simplifies maintenance operations: users have direct access to the inside of the product and are free to move without any obstructions. The grates are easy to remove for total sanitisation.



# PLAT

DESIGN FABRIZIO CRISÀ

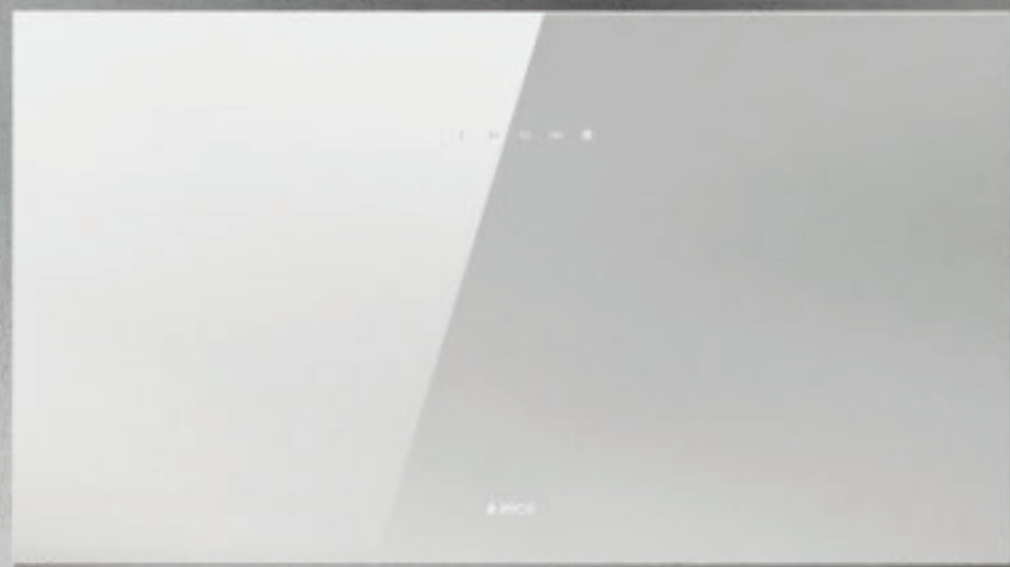

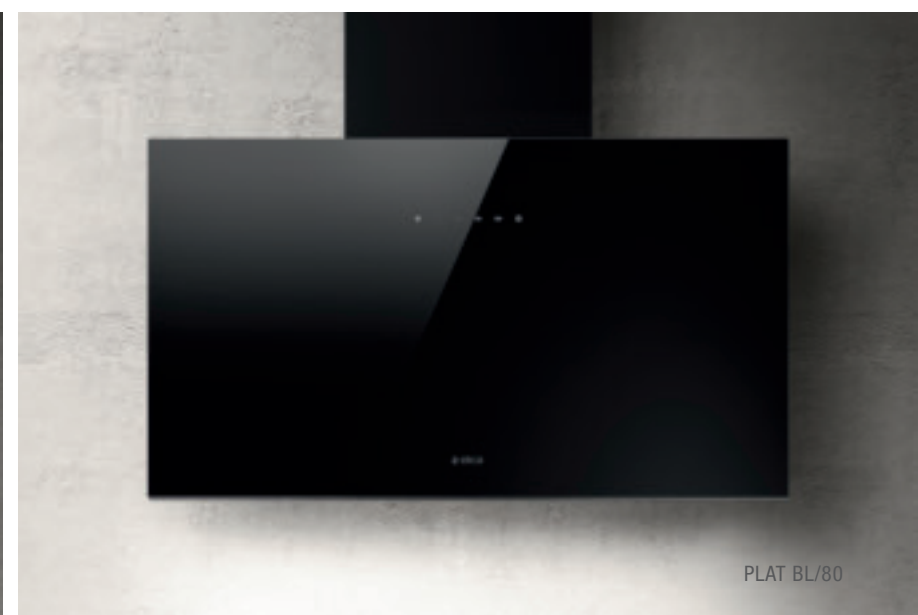



# PLAT

DESIGN FABRIZIO CRISA

55 - 80 cm

Filtrante Filtering

Vetro nero, vetro bianco

Black glass, white glass



EASY TO  
MAINTAIN



MULTI-D  
CAPTURE



LONG LIFE  
FILTER



COMFORT  
SILENCE



CM 50



CM 65



Ø150



ENERGY  
CLASS  
(A\*\*\*D)

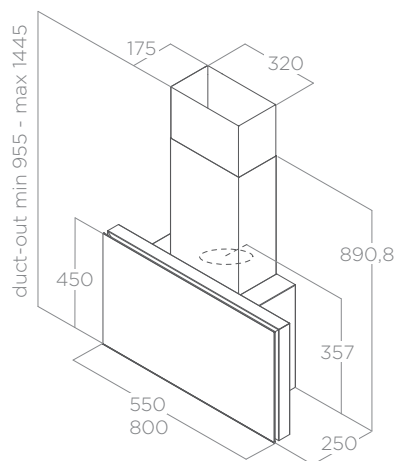

## ILLUMINAZIONE LIGHTING

Tipo Type	STRIP LED 1x7 W
Intensità Intensity	365 LUX
Temperatura Temperature	3500 K

## PERFORMANCE PERFORMANCE

Comandi Controls	Touch control capacitivo 3V+I 3S+B Capacitive Touch-control
Portata intensiva Booster airflow	710 m <sup>3</sup> /h
Livello sonoro min-max Noise level min-max	37 - 57 db(A)
Assorbimento totale Total absorption	277 W

Filtro grassi alluminio incluso Grease aluminium filter included  
Filtro carbone rigenerabile incluso Regenerable charcoal filter included

## ACCESSORI ACCESSORIES

Filtro carbone rigenerabile (*) Regenerable charcoal filter (*)	CFC0140423	55,00 €
Kit camino inox Stainless steel chimney kit	KIT0171543	115,00 €
Kit camino nero Black chimney kit	KIT0166364	115,00 €
(*) per versione 55 ordinare 2 pezzi (*) for version 55, order 2 pieces		
(*) per versione 80 ordinare 3 pezzi (*) for version 80, order 3 pieces		

## MODELLI MODELS

PLAT BL/F/55	PRF0164946	809,00 €
PLAT BL/F/80	PRF0164874	893,00 €
PLAT WH/F/55	PRF0165707	809,00 €
PLAT WH/F/80	PRF0165712	893,00 €







RULES

DESIGN FABRIZIO CRISÀ



# RULES

DESIGN FABRIZIO CRISÀ





RULES DEKTON



RULES BL



RULES NAKED



RULES NAKED



RULES BL



# RULES

DESIGN FABRIZIO CRISÀ

60 - 90 - 120 cm

Filtrante Filtering

Vetro nero, Dekton nero "sirius", rivestibile

Black glass, "Sirius" black Dekton, coverable



SPECIAL MATERIAL



EASY TO MAINTAIN



TOTAL INTEGRATION



LONG LIFE FILTER



COMFORT SILENCE



CM 50



CM 65



Ø150



ENERGY CLASS (A+++D)

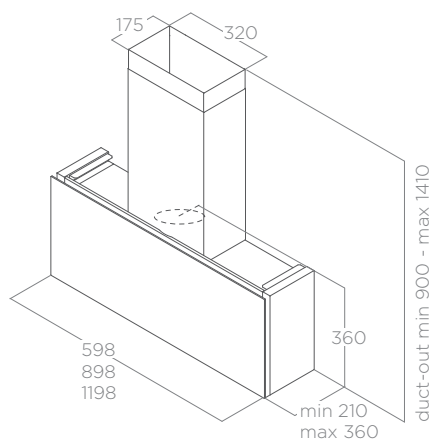

La versione NAKED di Rules è un modello unico, personalizzabile secondo le esigenze del cliente. Può essere rivestito con lo stesso materiale utilizzato per la tua cucina (Il pannello utilizzato non deve superare il peso totale di 4kg). Le immagini presentate sono esempi di estetiche esclusivamente dimostrative.

The NAKED version of Rules is a unique model that can be personalised to suit customer needs. It can be finished with the same material used for your kitchen (The panel used must not exceed the total weight of 4kg). The images shown are only an example of the possible solutions.



## ILLUMINAZIONE LIGHTING

Tipo Type	STRIP LED 2x7 W (DEKT - NAKED) STRIP LED 1x7 W (BL)
Intensità Intensity	365 (BL) - 310 (DEKT-NAKED) LUX
Temperatura Temperature	3500 K

## PERFORMANCE PERFORMANCE

	BL	DEKT / NAKED
Comandi Controls	Touch control capacitivo 3V+I 3S+B Capacitive Touch-control	Pulsantiera elettronica 3V+I 3S+B Electronic push button
Portata intensiva Booster airflow	700 m <sup>3</sup> /h	700 m <sup>3</sup> /h
Livello sonoro min-max Noise level min-max	40 - 58 db(A)	40 - 58 db(A)
Assorbimento totale Total absorption	277 W	280 W

Filtro grassi alluminio incluso Grease aluminium filter included

Filtro carbone rigenerabile incluso Regenerable charcoal filter included

## ACCESSORI ACCESSORIES

Filtro carbone rigenerabile (*) Regenerable charcoal filter (*)	CFC0166361	31,00 €
Kit camino inox Stainless steel chimney kit	KIT0171543	115,00 €
Kit camino nero Black chimney kit	KIT0166364	115,00 €
(*) per versione 60 ordinare 2 pezzi (*) for version 60, order 2 pieces (*) per versione 90 ordinare 3 pezzi (*) for version 90, order 3 pieces (*) per versione 120 ordinare 4 pezzi (*) for version 120, order 4 pieces		

## MODELLI MODELS

RULES BL/F/60	PRF0163752	751,00 €
RULES BL/F/90	PRF0163751	830,00 €
RULES BL/F/120	PRF0163753	935,00 €
RULES DEKT/F/60	PRF0163755	1.050,00 €
RULES DEKT/F/90	PRF0163754	1.145,00 €
RULES DEKT/F/120	PRF0163756	1.250,00 €
RULES NAKED/F/60	PRF0163758	751,00 €
RULES NAKED/F/90	PRF0163757	830,00 €
RULES NAKED/F/120	PRF0163759	935,00 €



Stand-alone o integrata grazie alla profondità regolabile

### Stand-alone or integrated thanks to adjustable depth

Le cucine di oggi, dove linee pulite ed essenziali sono dominanti, richiedono concetti di design flessibili e in grado di massimizzare gli spazi. Per questo nasce Rules, disegnata per essere in armonia con il progetto cucina. Questo nuovo modello garantisce un'installazione completamente personalizzabile, grazie all'innovativo sistema in grado di modulare millimetricamente la sua profondità in fase di installazione. Riducendo al minimo lo spessore, 21 cm, Rules diventa stand-alone e quasi scompare nella parete; aumentando la profondità fino a 36 cm si allinea perfettamente a pensili di ogni profondità. Le dimensioni di Rules sono le stesse di pensili standard con altezza di 36 cm e permettono una completa integrazione con tutte le composizioni di cucina.

Today's kitchens, dominated by clean and essential lines, require flexible design concepts able to maximise space. Hence Rules was born, designed to be in harmony with the kitchen project. This new model guarantees a completely customisable solution thanks to the innovative system allowing millimetric modulation of its depth during installation. When reduced to the minimum thickness of 21 cm, Rules becomes a stand-alone and almost disappears into the wall; when the depth is increased to 36 cm, it perfectly aligns with cabinets of any depth. The dimensions of Rules are the same as those of standard cabinets with height 36 cm, allowing complete integration with all kitchen compositions.

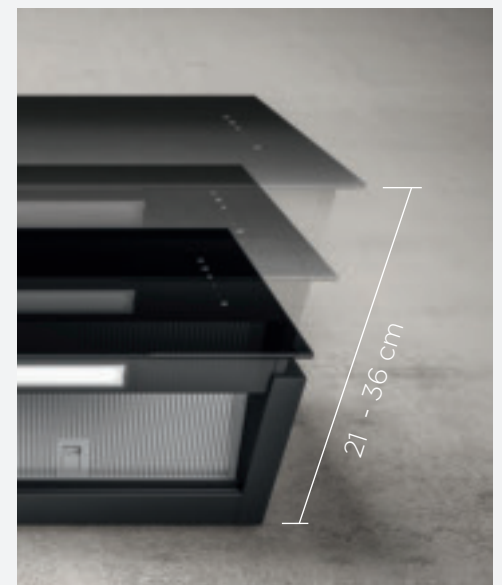

## Un vestito su misura A tailor-made outfit



Ampia è la scelta delle finiture disponibili, studiate per vestire al meglio ogni ambiente. La versione in vetro nero conferisce al prodotto un design minimal ed elegante. Per chi ricerca invece la totale integrazione con i mobili della propria cucina c'è la versione naked, pannellabile con la stessa anta dei pensili, che permette al prodotto di scomparire, mimetizzandosi perfettamente tra i cabinet.

Per una cappa dal carattere deciso c'è la versione in DEKTON® nero Sirius pensata per ricreare il total look in cucina. Questo materiale è durevole, resistente e di facile manutenzione e conferisce un aspetto sofisticato e moderno ad ogni ambiente.

A broad selection of available finishes, designed to bring out the best in every space. The version in black glass dresses the product with a minimalist and elegant design. For those looking for total integration with their kitchen furniture there's the naked version, which can be clad with the same door as the cabinets, thus totally concealing and disguising the product among the kitchen cabinets. For a more determined hood there's the version in black DEKTON® Sirius, designed to recreate a total look in the kitchen. A durable, resilient material that's easy to maintain, adding a sophisticated and modern feel to every space.



## Facile da pulire Easy to clean

Rules è dotata di griglie inclinate brevettate che, grazie alla loro speciale struttura, catturano le gocce di condensa e le convogliano all'interno di una vaschetta. Quando è necessaria una pulizia profonda, il collettore dell'acqua può essere rimosso senza la necessità di alcun attrezzo e igienizzato.

La linearità progettuale di Rules la rende estremamente facile da pulire. Tutte le finiture possono essere trattate facilmente con acqua e sapone neutro. Attraverso una semplice rimozione dei filtri antigrasso, è possibile accedere alla parte interna della cappa per la manutenzione dei filtri.

Rules comes with patented tilted grates, which thanks to their special structure, capture drops of condensate and convey them to a collection tray. When deep cleaning is required, the water tray can be removed and sanitised without the need for any tools. The linear design of Rules makes it extremely easy to clean. All the finishes can easily be treated with water and a neutral soap. By simply removing the grease filter, it's possible to reach the inside of the hood to service the filters.





# BLOOM-S

DESIGN FABRIZIO CRISÀ





BLOOM-S DEKTON



BLOOM-S DEKTON



BLOOM-S WH



BLOOM-S WH



# BLOOM-S

DESIGN FABRIZIO CRISÀ

85 cm

Aspirante Duct-out

Vetro bianco, Dekton nero "sirius"

White glass, "Sirius" black Dekton



EASY TO MAINTAIN



LONG LIFE FILTER



BACK ASPIRATION



COMFORT SILENCE



SPECIAL MATERIAL



CM 45



CM 55



Ø150



ENERGY CLASS (A+++/D)

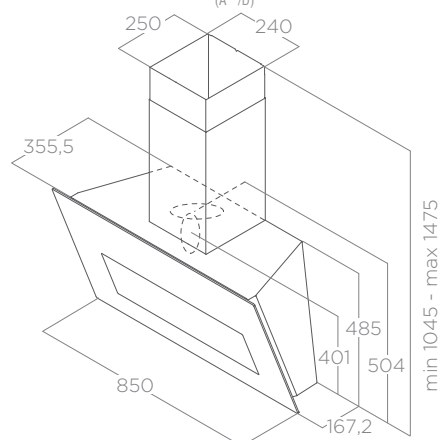

La parte frontale della cappa è caratterizzata da un visore mobile, azionabile manualmente, che consente di aumentare la captazione dei fumi durante le operazioni di cottura. La versione Dekton, grazie alle caratteristiche di questo materiale, ha un'alta resistenza ai raggi UV, ai graffi e alle macchie.

The front part of the hood is characterised by a mobile, manually operated visor, which allows increased fume extraction during cooking. The Dekton version, thanks to the characteristics of this material, is highly resistant to UV rays, scratches and dents.

## ILLUMINAZIONE LIGHTING

Tipo Type	STRIP LED 1x7 W
Intensità Intensity	365 LUX
Temperatura Temperature	3500 K

## PERFORMANCE PERFORMANCE

Comandi Controls	Touch control infrarossi 3V+2I 3S+2B Infrared touch control
Portata intensiva Booster airflow	750 m <sup>3</sup> /h
Livello sonoro min-max Noise level min-max	35 - 53 db(A)
Assorbimento totale Total absorption	277 W

Filtro grassi alluminio incluso Grease aluminium filter included  
Camino incluso Chimney included

## ACCESSORI ACCESSORIES

Filtro carbone Charcoal filter	CFC0140343	46,00 €
Filtro carbone rigenerabile Regenerable charcoal filter	CFC0162221	104,00 €

## MODELLI MODELS

BLOOM-S WH/A/85	PRF0164490	1.203,00 €
BLOOM-S DEKT/A/85	PRF0164475	1.203,00 €

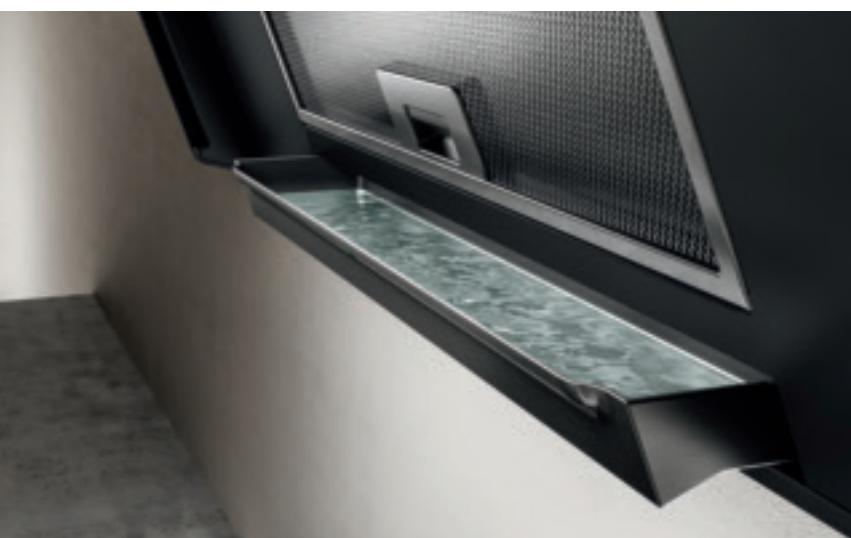



# MAJESTIC NO DRIP

DESIGN FABRIZIO CRISÀ

60 - 90 cm

Aspirante Duct-out

Vetro nero + acciaio inox

Black glass + stainless steel



BACK  
ASPIRATION



EASY TO  
MAINTAIN



LONG LIFE  
FILTER



CM 40



CM 60



Ø150



ENERGY  
CLASS  
(A++/D)

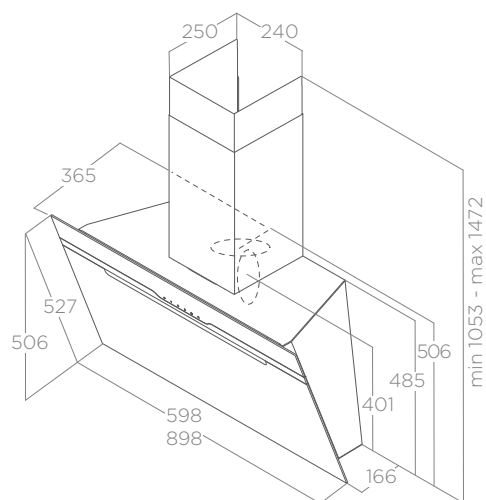

La cappa è dotata di un sistema di resistenze che permette al vetro di riscaldarsi, riducendo così la formazione della condensa. Un suo eventuale residuo viene raccolto in un apposito collettore.

The hood features a heating element system that allows the glass to heat up, thus reducing the formation of condensate. Any residual condensate is then collected in a dedicated manifold.

## ILLUMINAZIONE LIGHTING

Tipo Type	Strip Led 1x7 W
Intensità Intensity	141 LUX
Temperatura Temperature	3500 K

## PERFORMANCE PERFORMANCE

Comandi Controls	Touch control capacitivo 3V+I 3S+B Capacitive touch control
Portata intensiva Booster airflow	600 m <sup>3</sup> /h
Livello sonoro min-max Noise level min-max	46 - 60 db(A)
Assorbimento totale Total absorption	207 W

Filtro grassi alluminio incluso Grease aluminium filter included  
Camino incluso Chimney included

## ACCESSORI ACCESSORIES

Filtro carbone Charcoal filter	CFC0140343	46,00 €
Filtro carbone rigenerabile Regenerable charcoal filter	CFC0162221	104,00 €
Radiocomando bianco White remote control	KIT0121468	80,00 €
Radiocomando nero Black remote control	KIT0121469	80,00 €

## MODELLI MODELS

MAJESTIC NO DRIP BL/A/60	PRF0147731	1.029,00 €
MAJESTIC NO DRIP BL/A/90	PRF0147732	1.083,00 €





# MAJESTIC

DESIGN FABRIZIO CRISÀ



60 - 90 cm

Aspirante Duct-out

Vetro nero + acciaio inox, vetro bianco + acciaio inox

Black glass + stainless steel, white glass + stainless steel



BACK  
ASPIRATION



EASY TO  
MAINTAIN



LONG LIFE  
FILTER



CM 45



CM 55



Ø150



ENERGY  
CLASS  
(A++/D)

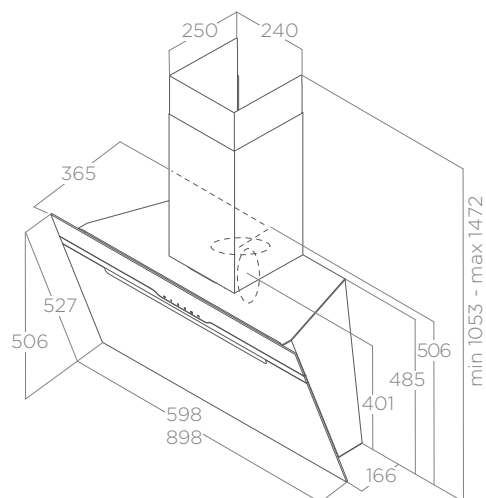

## ILLUMINAZIONE LIGHTING

Tipo Type	Led 2x2,5 W
Intensità Intensity	145 LUX
Temperatura Temperature	3000 K

## PERFORMANCE PERFORMANCE

Comandi Controls	Touch control capacitivo 3V+I 3S+B Capacitive touch control
Portata intensiva Booster airflow	691 m <sup>3</sup> /h
Livello sonoro min-max Noise level min-max	49 - 65 db(A)
Assorbimento totale Total absorption	255 W

Filtro grassi alluminio incluso Grease aluminium filter included  
Camino incluso Chimney included

## ACCESSORI ACCESSORIES

Filtro carbone Charcoal filter	CFC0140343	46,00 €
Filtro carbone rigenerabile Regenerable charcoal filter	CFC0162221	104,00 €

## MODELLI MODELS

MAJESTIC BL/A/60	PRF0117381A	808,00 €
MAJESTIC BL/A/90	PRF0116967A	921,00 €
MAJESTIC WH/A/60	PRF0124235A	808,00 €
MAJESTIC WH/A/90	PRF0124236A	921,00 €

OM AIR BLACK



OM AIR VINTAGE



OM AIR WHITE



OM AIR BEAUTY



OM AIR POP



OM AIR NATURE

# OM AIR

ELICA DESIGN CENTER

75 cm

Filtrante Filtering

Vetro bianco, vetro nero, vetro colorato

White glass, black glass, coloured glass

MULTI-D  
CAPTUREBACK  
ASPIRATIONEASY TO  
MAINTAINLONG LIFE  
FILTER

CM 40



CM 55

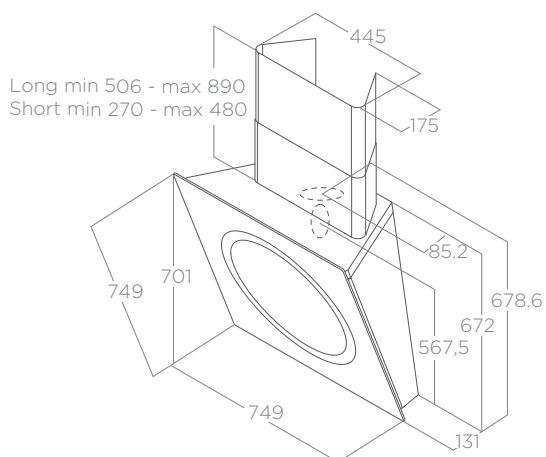

Ø150

ENERGY  
CLASS  
(A++/D)

Al momento dell'attivazione, l'anello centrale si muove elettronicamente verso l'interno consentendo alla cappa di attivare l'aspirazione perimetrale.  
When activated, the central ring electronically shifts inward, thus allowing the hood to activate perimeter extraction.

## ILLUMINAZIONE LIGHTING

Tipo Type	Strip Led 1x7 W
Intensità Intensity	113 LUX
Temperatura Temperature	4000 K

## PERFORMANCE PERFORMANCE

Comandi Controls	Touch control capacitivo 3V+I 3S+B Capacitive touch control
Portata intensiva Booster airflow	650 m <sup>3</sup> /h
Livello sonoro min-max Noise level min-max	42 - 60 db(A)
Assorbimento totale Total absorption	247 W

Filtro grassi alluminio incluso Grease aluminium filter included  
Filtro carbone incluso Charcoal filter included

## ACCESSORI ACCESSORIES

Filtro carbone Charcoal filter	CFC0140343	46,00 €
Filtro carbone rigenerabile Regenerable charcoal filter	CFC0162221	104,00 €
Kit camino lungo Long chimney kit	KIT0010439	222,00 €
Kit camino corto Short chimney kit	KIT0010700	160,00 €

## MODELLI MODELS

OM AIR BL/F/75	PRF0094744	2.160,00 €
OM AIR WH/F/75	PRF0094734	2.160,00 €
OM AIR NATURE/F/75	PRF0100231	2.502,00 €
OM AIR POP/F/75	PRF0098373	2.502,00 €
OM AIR VINTAGE/F/75	PRF0100138	2.502,00 €
OM AIR BEAUTY/F/75	PRF0100137	2.502,00 €





MINI OM WH



MINI OM BL

## MINI OM

ELICA DESIGN CENTER

55 cm

Filtrante Filtering

Vetro bianco, vetro nero

White glass, black glass



BACK  
ASPIRATION



EASY TO  
MAINTAIN



LONG LIFE  
FILTER



CM 40



CM 50



Ø150



ENERGY  
CLASS  
(A→D)

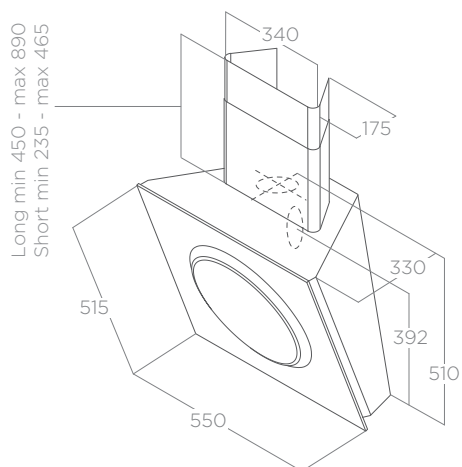

### ILLUMINAZIONE LIGHTING

Tipo Type	Led 2x2,5 W
Intensità Intensity	341 LUX
Temperatura Temperature	3500 K

### PERFORMANCE PERFORMANCE

Comandi Controls	Pulsantiera soft light 3V 3S Soft light push button
Portata massima Max airflow	590 m <sup>3</sup> /h
Livello sonoro min-max Noise level min-max	48 - 63 db(A)
Assorbimento totale Total absorption	225 W

Filtro grassi alluminio incluso Grease aluminium filter included  
Filtro carbone rigenerabile incluso Regenerable charcoal filter included

### ACCESSORI ACCESSORIES

Filtro carbone rigenerabile Regenerable charcoal filter	CFC0140423	55,00 €
Kit camino lungo Long chimney kit	KIT01513	222,00 €
Kit camino corto Short chimney kit	KIT01797	201,00 €

### MODELLI MODELS

MINI OM BL/F/55	61614583A	1.695,00 €
MINI OM WH/F/55	61614584A	1.695,00 €



# SINFONIA

DESIGN FABRIZIO CRISÀ

80 cm

Filtrante Filtering

Vetro bianco, vetro nero

White glass, black glass



BACK  
ASPIRATION



EASY TO  
MAINTAIN



LONG LIFE  
FILTER



CM 30



CM 35



Ø150



ENERGY  
CLASS  
(A++/D)

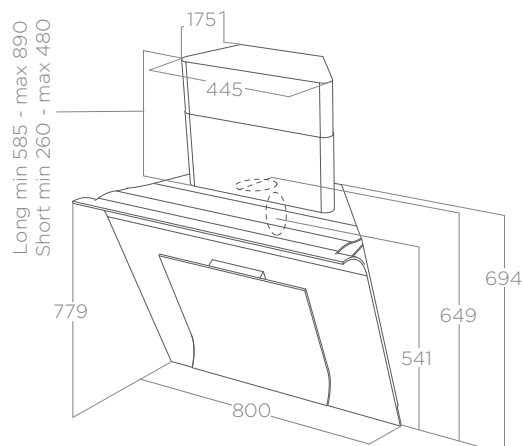

## ILLUMINAZIONE LIGHTING

Tipo Type	Neon 2x14 W
Intensità Intensity	59 LUX
Temperatura Temperature	4000 K

## PERFORMANCE PERFORMANCE

Comandi Controls	Touch control capacitivo 3V+I 3S+B Capacitive touch control
Portata intensiva Booster airflow	760 m <sup>3</sup> /h
Livello sonoro min-max Noise level min-max	56 - 70 db(A)
Assorbimento totale Total absorption	328 W

Filtro grassi alluminio incluso Grease aluminium Filter included  
Filtro carbone rigenerabile incluso Regenerable charcoal filter included

## ACCESSORI ACCESSORIES

Filtro carbone rigenerabile Regenerable charcoal filter	CFC0140088	58,00 €
Kit camino lungo Long chimney kit	KIT0010439	222,00 €
Kit camino corto Short chimney kit	KIT0010700	160,00 €

## MODELLI MODELS

SINFONIA BL/F/80	PRF0010417B	1.863,00 €
SINFONIA WH/F/80	PRF0010418B	1.863,00 €



# VERTIGO

ELICA DESIGN CENTER

90 - 120 cm

Filtrante Filtering

Vetro bianco, vetro nero

White glass, black glass



BACK  
ASPIRATION



EASY TO  
MAINTAIN



LONG LIFE  
FILTER



CM 45



CM 50



Ø150



ENERGY  
CLASS  
(A++/D)

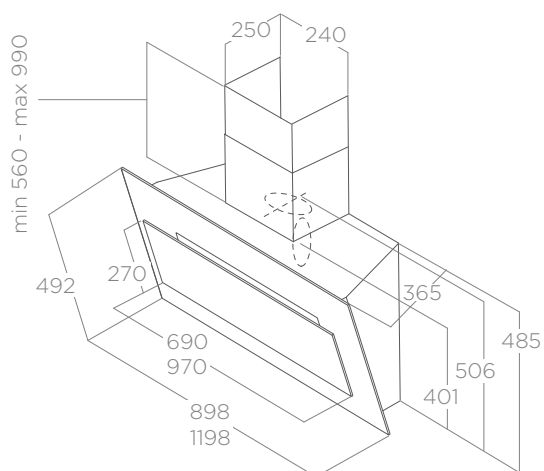

## ILLUMINAZIONE LIGHTING

Tipo Type	STRIP LED 1x7W
Intensità Intensity	301 LUX
Temperatura Temperature	3500 K

## PERFORMANCE PERFORMANCE

Comandi Controls	Touch control infrarossi 3V+I 3S+B Infrared touch control
Portata intensiva Booster airflow	740 m <sup>3</sup> /h
Livello sonoro min-max Noise level min-max	50 - 66 db(A)
Assorbimento totale Total absorption	267 W

Filtro grassi alluminio incluso Grease aluminium filter included  
Filtro carbone rigenerabile incluso Regenerable charcoal filter included

## ACCESSORI ACCESSORIES

Filtro carbone Charcoal filter	CFC0140343	46,00 €
Filtro carbone rigenerabile Regenerable charcoal filter	CFC0162221	104,00 €
Kit camino acciaio inox Stainless steel chimney kit	KIT0177845	115,00 €

## MODELLI MODELS

VERTIGO BL/F/90	PRF0079553C	1.170,00 €
VERTIGO BL/F/120	PRF0079555C	1.289,00 €
VERTIGO WH/F/90	PRF0079554C	1.170,00 €
VERTIGO WH/F/120	PRF0079556C	1.289,00 €



# ELLE

DESIGN FABRIZIO CRISÀ

80 cm

Filtrante Filtering

Vetro nero, vetro bianco

Black glass, white glass



EASY TO  
MAINTAIN



LONG LIFE  
FILTER



CM 40



CM 55



Ø150



ENERGY  
CLASS  
(A++)

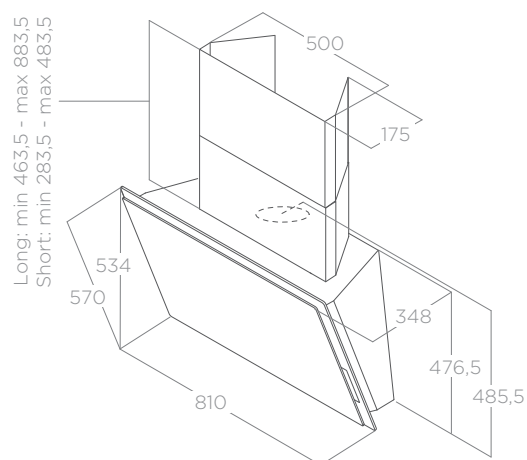

## ILLUMINAZIONE LIGHTING

Tipo Type	Strip Led 1x7 W
Intensità Intensity	141 LUX
Temperatura Temperature	4000 K

## PERFORMANCE PERFORMANCE

Comandi Controls	Touch control infrarossi 3V+I 3S+B Infrared touch control
Portata intensiva Booster airflow	670 m <sup>3</sup> /h
Livello sonoro min-max Noise level min-max	43 - 62 dB(A)
Assorbimento totale Total absorption	247 W

Filtro grassi alluminio incluso Grease aluminium filter included  
Filtro carbone incluso Charcoal filter included

## ACCESSORI ACCESSORIES

Filtro carbone Charcoal filter	CFC0140343	46,00 €
Filtro carbone rigenerabile Regenerable charcoal filter	CFC0162221	104,00 €
Kit camino lungo Long chimney kit	KIT0010703	214,00 €
Kit camino corto Short chimney kit	KIT0010704	160,00 €

## MODELLI MODELS

ELLE BL/F/80	PRF0094251	1.081,00 €
ELLE WH/F/80	PRF0097706	1.081,00 €

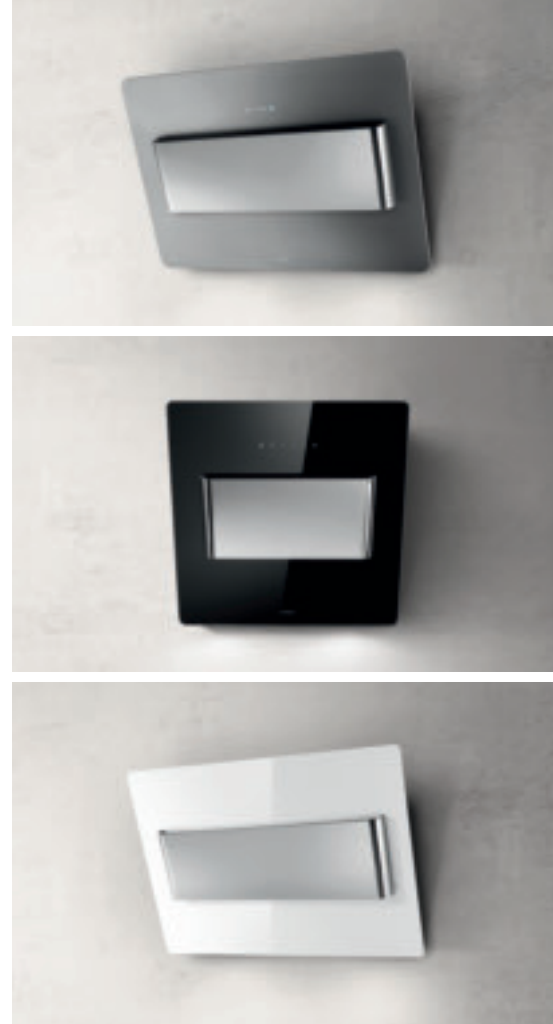

# BELT

DESIGN FABRIZIO CRISÀ

55 - 80 cm

Filtrante Filtering

Vetro nero, vetro bianco, acciaio inox

Black glass, white glass, stainless steel



EASY TO MAINTAIN



BACK ASPIRATION



LONG LIFE FILTER



CM 45



CM 50



Ø150



ENERGY CLASS (A+/D)

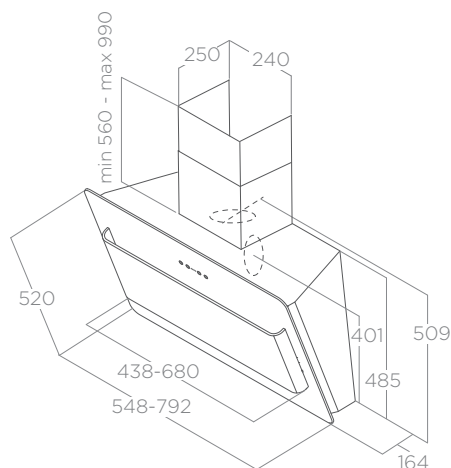

## ILLUMINAZIONE LIGHTING

Tipo Type	Led 2x2,5 W
Intensità Intensity	381 LUX
Temperatura Temperature	3500 K

## PERFORMANCE PERFORMANCE

Comandi Controls	BL/WH Touch control capacitivo 3V+I 3S+B Capacitive touch control	IX Touch control infrarossi 3V+I 3S+B Infrared touch control
Portata intensiva Booster airflow	590 m <sup>3</sup> /h	
Livello sonoro min-max Noise level min-max	46 - 61 db(A)	
Assorbimento totale Total absorption	225 W	

Filtro grassi alluminio incluso Grease aluminium filter included  
Filtro carbone incluso Charcoal filter included

## ACCESSORI ACCESSORIES

Filtro carbone Charcoal filter	CFC0140343	46,00 €
Filtro carbone rigenerabile Regenerable charcoal filter	CFC0162221	104,00 €
Kit camino acciaio inox Stainless steel chimney kit	KIT0177845	115,00 €

## MODELLI MODELS

BELT IX/F/55	PRF0034012C	867,00 €
BELT IX/F/80	PRF0033852C	975,00 €
BELT BL/F/55	PRF0034211C	867,00 €
BELT BL/F/80	PRF0032793C	975,00 €
BELT WH/F/55	PRF0038445C	867,00 €
BELT WH/F/80	PRF0038443C	975,00 €

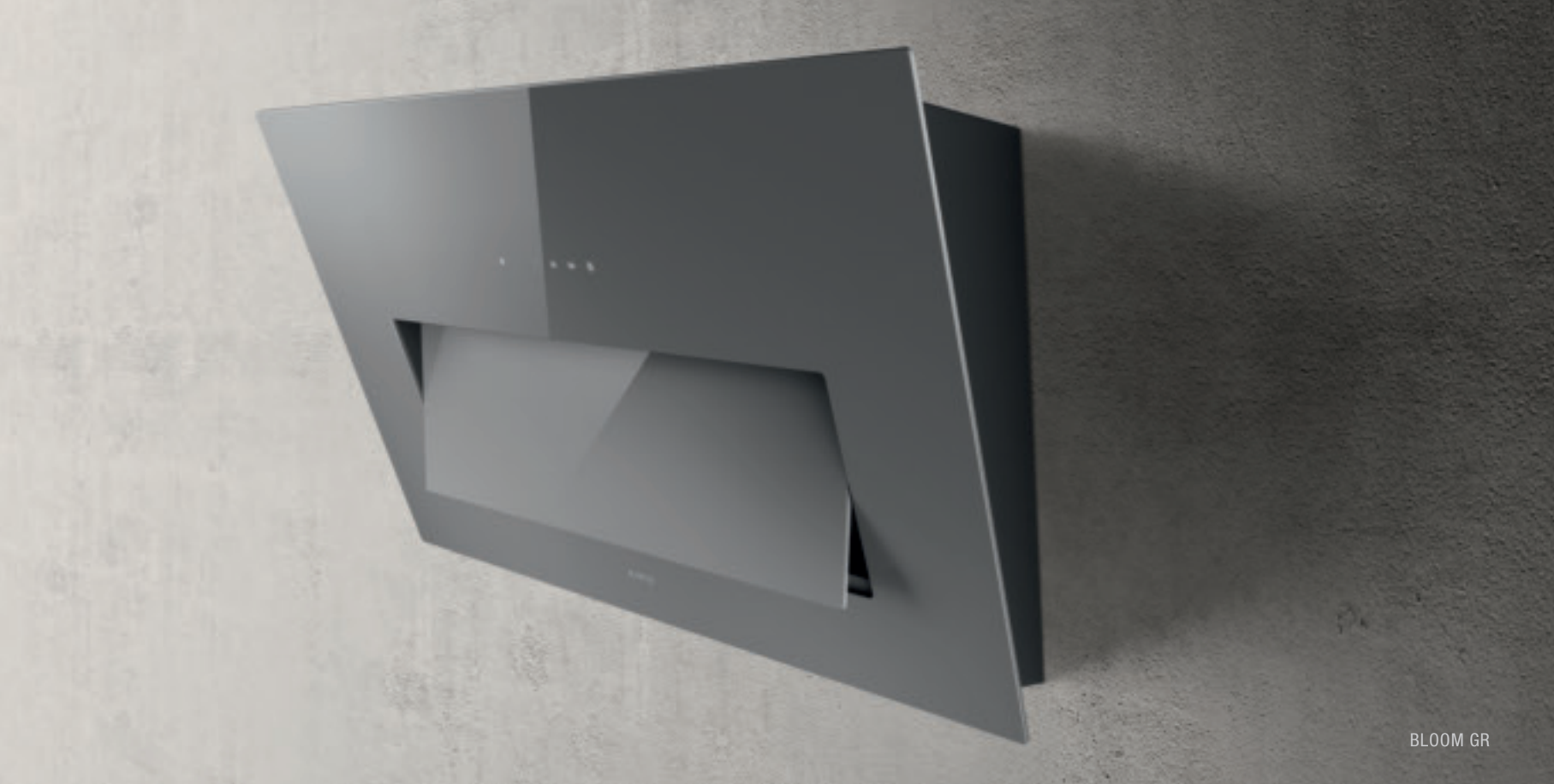

BLOOM GR



BLOOM GR



BLOOM BL



BLOOM BL



# BLOOM

DESIGN FABRIZIO CRISA

85 cm

Aspirante Duct-out

Vetro nero, vetro grigio

Black glass, grey glass



EASY TO  
MAINTAIN



LONG LIFE  
FILTER



BACK  
ASPIRATION



CM 45



CM 55



Ø150



ENERGY  
CLASS  
(A\*\*/D)

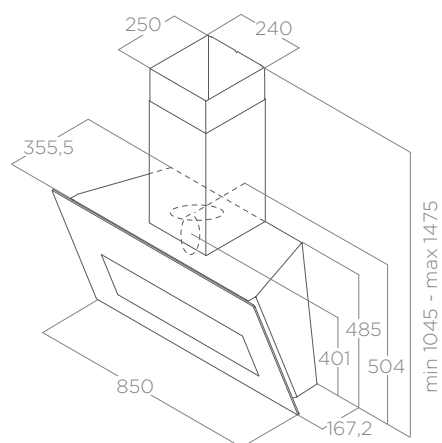

La parte frontale della cappa è caratterizzata da un visore mobile, azionabile manualmente, che consente di aumentare la captazione dei fumi durante le operazioni di cottura. The front part of the hood is characterised

by a mobile, manually operated visor, which allows increased fume extraction during cooking.

## ILLUMINAZIONE LIGHTING

Tipo Type	STRIP LED 1x7 W
Intensità Intensity	365 LUX
Temperatura Temperature	3500 K

## PERFORMANCE PERFORMANCE

Comandi Controls	Touch control capacitivo 3V+I 3S+B Capacitive touch control
Portata intensiva Booster airflow	750 m <sup>3</sup> /h
Livello sonoro min-max Noise level min-max	35 - 56 db(A)
Assorbimento totale Total absorption	277 W

Filtro grassi alluminio incluso Grease aluminium filter included  
Camino incluso Chimney included

## ACCESSORI ACCESSORIES

Filtro carbone Charcoal filter	CFC0140343	46,00 €
Filtro carbone rigenerabile Regenerable charcoal filter	CFC0162221	104,00 €

## MODELLI MODELS

BLOOM BL/A/85	PRF0164459	839,00 €
BLOOM GR/A/85	PRF0164462	839,00 €



STRIPE URBAN CAST IRON



STRIPE URBAN ZINC

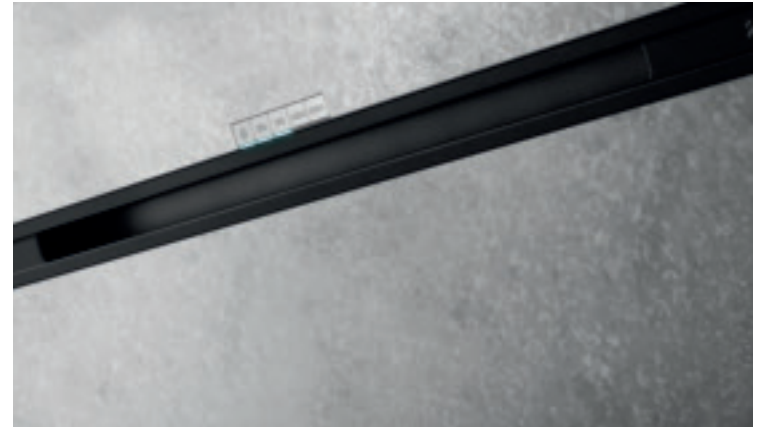

# STRIPE URBAN

ELICA DESIGN CENTER

90 cm

Aspirante Duct-out

Metallo effetto ghisa, metallo effetto zincato

Cast iron effect metal, zinc coating effect metal



EASY TO MAINTAIN



BACK ASPIRATION



LONG LIFE FILTER



SPECIAL MATERIAL



CM 45



CM 50



Ø150



ENERGY CLASS (A+/D)

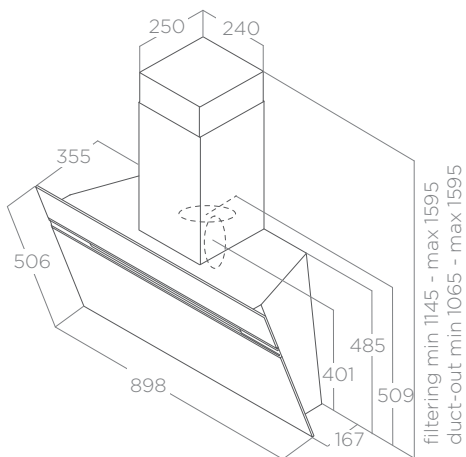

In linea con i nuovi trend delle cucine, che vede sempre più presente un design industrial e Urban, Elica ha ideato nuove combinazioni di finiture che permettono alla cappa di integrarsi perfettamente con questo stile.

In line with latest kitchen trends, where industrial and urban design is continuously gaining ground, Elica has developed new combinations of finishes allowing the hood to be perfectly integrated with this style.

## ILLUMINAZIONE LIGHTING

Tipo Type	Led 2x2,5 W
Intensità Intensity	381 LUX
Temperatura Temperature	3500 K

## PERFORMANCE PERFORMANCE

Comandi Controls	Pulsantiera elettronica 3V+I 3S+B Electronic push button
Portata intensiva Booster airflow	757 m <sup>3</sup> /h
Livello sonoro min-max Noise level min-max	50 - 65 db(A)
Assorbimento totale Total absorption	265 W

Filtro grassi alluminio incluso Grease aluminium filter included  
Camino incluso Chimney included

## ACCESSORI ACCESSORIES

Filtro carbone Charcoal filter	CFC0140343	46,00 €
Filtro carbone rigenerabile Regenerable charcoal filter	CFC0162221	104,00 €

## MODELLI MODELS

STRIPE URBAN ZINC/A/90	PRF0147739	748,00 €
STRIPE URBAN CAST IRON/A/90	PRF0147738	748,00 €





# STRIPE

ELICA DESIGN CENTER

60 - 80 - 90 cm

Aspirante Duct-out

Vetro nero, vetro bianco, acciaio inox

Black glass, white glass, stainless steel



EASY TO  
MAINTAIN



LONG LIFE  
FILTER



BACK  
ASPIRATION



CM 45



CM 50



Ø150



ENERGY  
CLASS  
(A++/D)

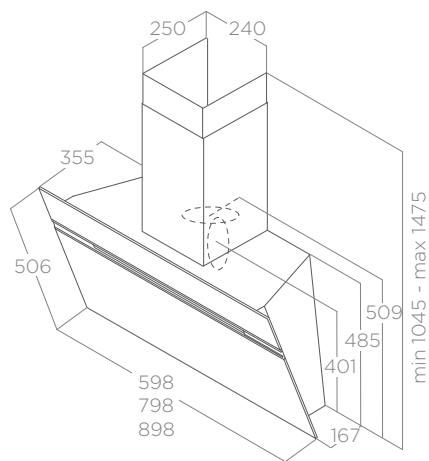

## ILLUMINAZIONE LIGHTING

Tipo Type	Led 2x2,5 W
Intensità Intensity	203 LUX
Temperatura Temperature	3000 K

## PERFORMANCE PERFORMANCE

Comandi Controls	BL/WH Touch control capacitivo 3V+I 3S+B Capacitive touch control	IX Pulsantiera elettronica 3V+I 3S+B Electronic push button
	Portata intensiva Booster airflow	
Livello sonoro min-max Noise level min-max		757 m <sup>3</sup> /h
Assorbimento totale Total absorption		50 - 65 db(A)
		265 W

Filtro grassi alluminio incluso Grease aluminium filter included  
Camino incluso Chimney included

## ACCESSORI ACCESSORIES

Filtro carbone Charcoal filter	CFC0140343	46,00 €
Filtro carbone rigenerabile Regenerable charcoal filter	CFC0162221	104,00 €

## MODELLI MODELS

STRIPE IX/A/60	PRF0110514B	640,00 €
STRIPE IX/A/90	PRF0110515B	748,00 €
STRIPE BL/A/60	PRF0101142B	640,00 €
STRIPE BL/A/80	PRF0164806	748,00 €
STRIPE BL/A/90	PRF0101143B	748,00 €
STRIPE WH/A/60	PRF0101144B	640,00 €
STRIPE WH/A/80	PRF0164805	748,00 €
STRIPE WH/A/90	PRF0101145B	748,00 €



APLOMB BL/90



APLOMB WH/60



APLOMB BL/90



APLOMB BL/60





# APLOMB

DESIGN FABRIZIO CRISA

60 - 90 cm

Aspirante Duct-out

Vetro nero, vetro bianco

Black glass, white glass



EASY TO MAINTAIN



MULTI-D CAPTURE



LONG LIFE FILTER



CM 45



CM 65



Ø150



ENERGY CLASS (A<sup>+++</sup>/D)

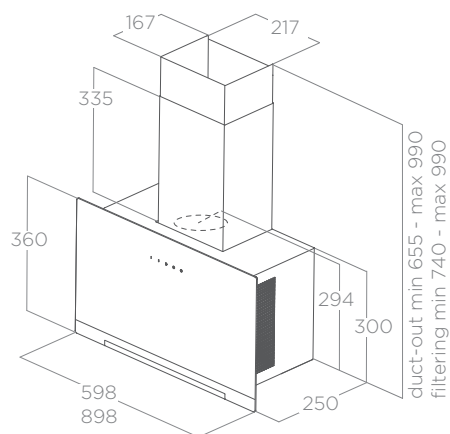

Il Delay switch off di Aplomb è una funzione timer intelligente che consente all'utente di impostare lo spegnimento automatico delle velocità selezionate dopo un tempo prestabilito. Inoltre, la cappa è dotata di un sistema di sostegno del pannello frontale che permette di mantenerlo aperto per facilitare la manutenzione ordinaria e straordinaria del prodotto. The Aplomb Switch Off Delay is a smart timer function allowing the user to programme the automatic shut-down of the selected speed after a pre-set time. Moreover, the hood features a front panel support system, which means it can be kept open when performing routine or corrective maintenance on the product.

## ILLUMINAZIONE LIGHTING

Tipo Type	STRIP LED 1x3 W
Intensità Intensity	84 LUX
Temperatura Temperature	3500 K

## PERFORMANCE PERFORMANCE

Comandi Controls	Touch control capacitivo 3V+I 3S+B Capacitive touch control
Portata intensiva Booster airflow	680 m <sup>3</sup> /h
Livello sonoro min-max Noise level min-max	51 - 64 db(A)
Assorbimento totale Total absorption	233 W

Filtro grassi alluminio incluso Grease aluminium filter included  
Camino incluso Chimney included

## ACCESSORI ACCESSORIES

Filtro carbone Charcoal filter	CFC0140343	46,00 €
Filtro carbone rigenerabile Regenerable charcoal filter	CFC0162221	104,00 €

## MODELLI MODELS

APLOMB BL/A/60	PRF0166938	567,00 €
APLOMB BL/A/90	PRF0166939	620,00 €
APLOMB WH/A/60	PRF0166940	567,00 €
APLOMB WH/A/90	PRF0166941	620,00 €



# ELEKTRA

ELICA DESIGN CENTER

55 - 80 cm

Filtrante Filtering

Acciaio inox Stainless steel



EASY TO  
MAINTAIN



LONG LIFE  
FILTER



CM 45



CM 65



Ø150



ENERGY  
CLASS  
(A+++/D)

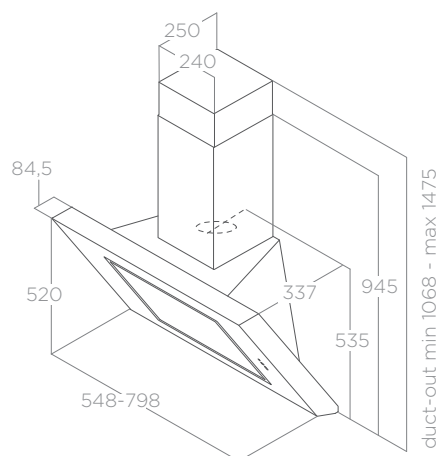

## ILLUMINAZIONE LIGHTING

Tipo Type	Led 2x1 W
Intensità Intensity	136 LUX
Temperatura Temperature	3500 K

## PERFORMANCE PERFORMANCE

Comandi Controls	Pulsantiera elettronica con display 3V+I 3S+B Electronic push button with display
Portata intensiva Booster airflow	647 m <sup>3</sup> /h
Livello sonoro min-max Noise level min-max	45 - 63 db(A)
Assorbimento totale Total absorption	252 W

Filtro carbone rigenerabile incluso Regenerable charcoal filter included

## ACCESSORI ACCESSORIES

Filtro carbone rigenerabile Regenerable charcoal filter	CFC0140088	58,00 €
Kit camino Chimney kit	KIT0008747A	137,00 €

## MODELLI MODELS

ELEKTRA IX/F/55	PRF0006407B	580,00 €
ELEKTRA IX/F/80	PRF0006872B	640,00 €



L'ESSENZA WH/60



L'ESSENZA WH/90



L'ESSENZA BL/60



L'ESSENZA BL/90

# L'ESSENZA

DESIGN FABRIZIO CRISÀ

60 - 90 cm

Aspirante Duct-out

Vetro nero, vetro bianco

Black glass, white glass



BACK  
ASPIRATION



EASY TO  
MAINTAIN



LONG LIFE  
FILTER



CM 45



CM 55



Ø150



ENERGY  
CLASS  
(A++/D)

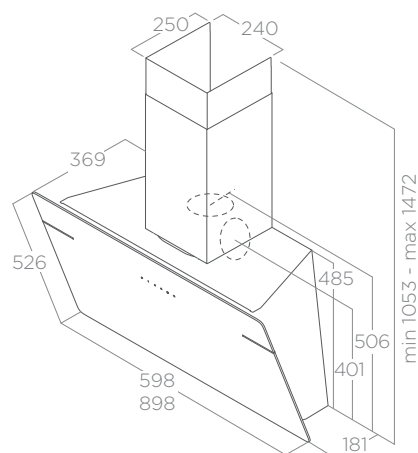

## ILLUMINAZIONE LIGHTING

Tipo Type	Led 2x2,5 W
Intensità Intensity	145 LUX
Temperatura Temperature	3000 K

## PERFORMANCE PERFORMANCE

Comandi Controls	Touch control capacitivo 3V+I 3S+B Capacitive touch control
Portata intensiva Booster airflow	691 m <sup>3</sup> /h
Livello sonoro min-max Noise level min-max	49 - 65 db(A)
Assorbimento totale Total absorption	255 W

Filtro grassi alluminio incluso Grease aluminium filter included  
Camino incluso Chimney included

## ACCESSORI ACCESSORIES

Filtro carbone Charcoal filter	CFC0140343	46,00 €
Filtro carbone rigenerabile Regenerable charcoal filter	CFC0162221	104,00 €

## MODELLI MODELS

L'ESSENZA BL/A/60	PRF0117403A	678,00 €
L'ESSENZA BL/A/90	PRF0117374A	781,00 €
L'ESSENZA WH/A/60	PRF0124233A	678,00 €
L'ESSENZA WH/A/90	PRF0124234A	781,00 €



SHEEN-S WH/60



SHEEN-S BL/90



# SHEEN-S

DESIGN FABRIZIO CRISÀ

60 - 90 cm

Aspirante Duct-out

Vetro nero, vetro bianco

Black glass, white glass



EASY TO MAINTAIN



LONG LIFE FILTER



CM 45



CM 65



Ø150



ENERGY CLASS (A+/D)

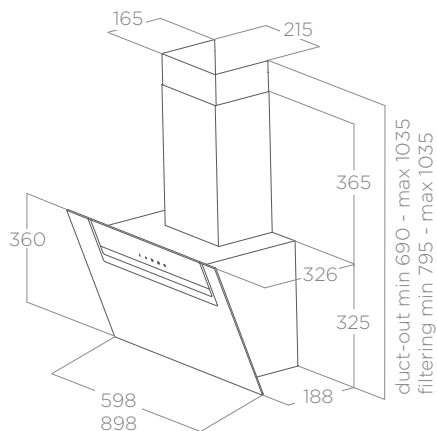

Il Delay switch off è una funzione timer intelligente che consente all'utente di impostare lo spegnimento automatico delle velocità selezionata dopo un tempo prestabilito. The Switch Off Delay is a smart timer function allowing the user to programme the automatic shut-down of the selected speed after a pre-set time.

## ILLUMINAZIONE LIGHTING

Tipo Type	Led 2x1,5 W
Intensità Intensity	180 LUX
Temperatura Temperature	3500 K

## PERFORMANCE PERFORMANCE

Comandi Controls	Touch control capacitivo 3V+I 3S+B Capacitive touch control
Portata intensiva Booster airflow	650 m <sup>3</sup> /h
Livello sonoro min-max Noise level min-max	52 - 65 db(A)
Assorbimento totale Total absorption	233 W

Filtro grassi alluminio incluso Grease aluminium filter included  
Camino incluso Chimney included

## ACCESSORI ACCESSORIES

Filtro carbone Charcoal filter	CFC0140343	46,00 €
Filtro carbone rigenerabile Regenerable charcoal filter	CFC0162221	104,00 €

## MODELLI MODELS

SHEEN-S BL/A/60	PRF0166928	504,00 €
SHEEN-S BL/A/90	PRF0166929	557,00 €
SHEEN-S WH/A/60	PRF0166930	504,00 €
SHEEN-S WH/A/90	PRF0166931	557,00 €



SHY-S WH/60



SHY-S BL/90



# SHY-S

DESIGN FABRIZIO CRISÀ

60 - 90 cm

Aspirante Duct-out

Vetro nero, vetro bianco

Black glass, white glass



EASY TO  
MAINTAIN



LONG LIFE  
FILTER



CM 45



CM 65



Ø150



ENERGY  
CLASS  
(A+/D)

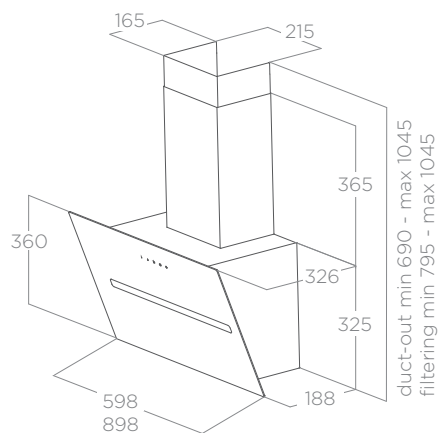

## ILLUMINAZIONE LIGHTING

Tipo Type	Led 2x1,5 W
Intensità Intensity	180 LUX
Temperatura Temperature	3500 K

## PERFORMANCE PERFORMANCE

Comandi Controls	Touch control capacitivo 3V+I 3S+B Capacitive touch control
Portata intensiva Booster airflow	650 m <sup>3</sup> /h
Livello sonoro min-max Noise level min-max	52 - 65 db(A)
Assorbimento totale Total absorption	233 W

Filtro grassi alluminio incluso Grease aluminium filter included  
Camino incluso Chimney included

## ACCESSORI ACCESSORIES

Filtro carbone Charcoal filter	CFC0140343	46,00 €
Filtro carbone rigenerabile Regenerable charcoal filter	CFC0162221	104,00 €

## MODELLI MODELS

SHY-S BL/A/60	PRF0166932	504,00 €
SHY-S BL/A/90	PRF0166933	557,00 €
SHY-S WH/A/60	PRF0166934	504,00 €
SHY-S WH/A/90	PRF0166935	557,00 €



Il Delay switch off è una funzione timer intelligente che consente all'utente di impostare lo spegnimento automatico delle velocità selezionata dopo un tempo prestabilito. The Switch Off Delay is a smart timer function allowing the user to programme the automatic shut-down of the selected speed after a pre-set time.

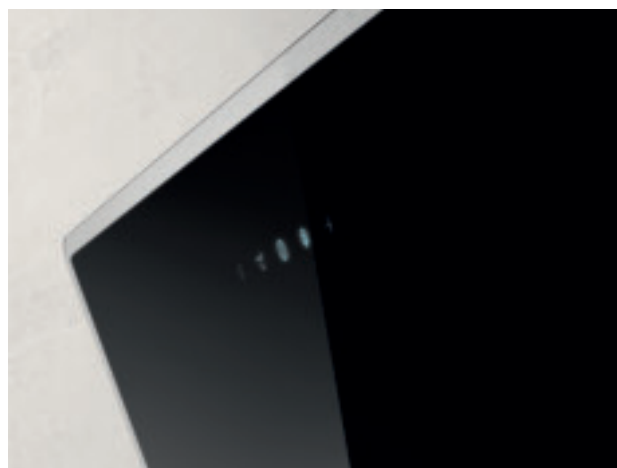

# SHIRE

DESIGN FABRIZIO CRISÀ

60 - 90 cm

Aspirante Duct-out

Vetro nero, vetro bianco

Black glass, white glass



EASY TO  
MAINTAIN



LONG LIFE  
FILTER



CM 45



CM 65



Ø150



ENERGY  
CLASS  
(A++/D)

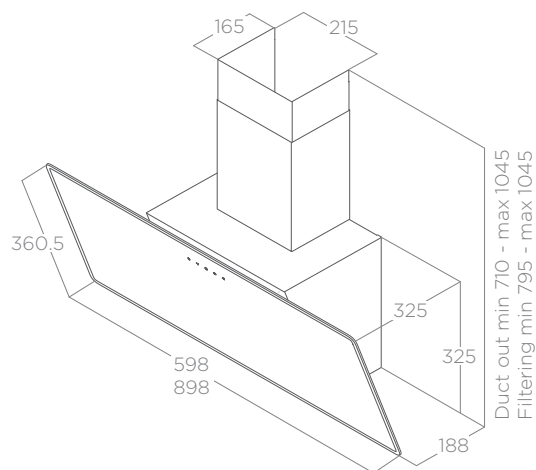

## ILLUMINAZIONE LIGHTING

Tipo Type	Led 2x1 W
Intensità Intensity	120 LUX
Temperatura Temperature	3500 K

## PERFORMANCE PERFORMANCE

Comandi Controls	Touch control capacitivo 2V+I 2S+B Capacitive touch control
Portata intensiva Booster airflow	650 m <sup>3</sup> /h
Livello sonoro min-max Noise level min-max	52 - 64 db(A)
Assorbimento totale Total absorption	232 W

Filtro grassi alluminio incluso Grease aluminium filter included  
Camino incluso Chimney included

## ACCESSORI ACCESSORIES

Filtro carbone Charcoal filter	CFC0140343	46,00 €
Filtro carbone rigenerabile Regenerable charcoal filter	CFC0162221	104,00 €

## MODELLI MODELS

SHIRE BL/A/60	PRF0119819A	455,00 €
SHIRE BL/A/90	PRF0119829A	513,00 €
SHIRE WH/A/60	PRF0119823A	455,00 €
SHIRE WH/A/90	PRF0119828A	513,00 €





# STONE

ELICA DESIGN CENTER

Ø33 cm

Aspirante Duct-out

Acciaio inox, bianco

Stainless steel, white



LONG LIFE  
FILTER



CM 50



CM 65



Ø150



ENERGY  
CLASS  
(A++/D)

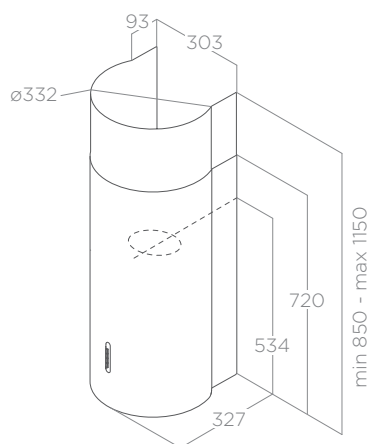

## ILLUMINAZIONE LIGHTING

Tipo Type	Led 2x2,5 W
Intensità Intensity	457 LUX
Temperatura Temperature	2700 K

## PERFORMANCE PERFORMANCE

Comandi Controls	Pulsantiera soft light 3V 3S Soft light push button
Portata massima Max airflow	559 m <sup>3</sup> /h
Livello sonoro min-max Noise level min-max	44 - 67 db(A)
Assorbimento totale Total absorption	180 W

Filtro grassi alluminio incluso Grease aluminium filter included  
Camino incluso Chimney included

## ACCESSORI ACCESSORIES

Filtro carbone Charcoal filter	CFC0141529A	35,00 €
Filtro carbone rigenerabile Regenerable charcoal filter	CFC0141725A	78,00 €

## MODELLI MODELS

STONE IX/A/33	61412862B	834,00 €
STONE WH/A/33	PRF0007123A	834,00 €



# TUBE PRO

ELICA DESIGN CENTER

Ø 43 cm

Aspirante Duct-out

Acciaio inox, nero effetto soft touch, bianco effetto soft touch  
Stainless steel, black soft touch effect, white soft touch effect



BACK  
ASPIRATION



LONG LIFE  
FILTER



CM 50



CM 65



Ø150



ENERGY  
CLASS  
(A++/D)

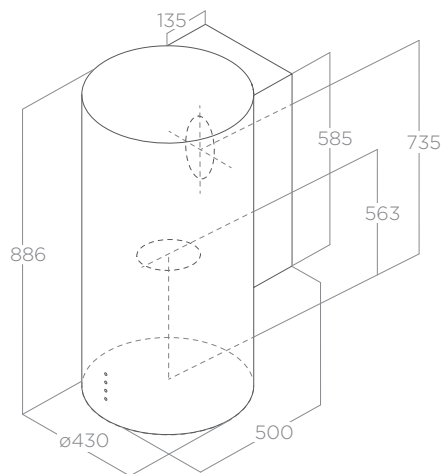

## ILLUMINAZIONE LIGHTING

Tipo Type	Led 2x3 W
Intensità Intensity	457 LUX
Temperatura Temperature	2700 K

## PERFORMANCE PERFORMANCE

Comandi Controls	Pulsantiera meccanica 3V 3S Mechanical push button
Portata massima Max airflow	603 m <sup>3</sup> /h
Livello sonoro min-max Noise level min-max	47 - 68 db(A)
Assorbimento totale Total absorption	256 W

Filtro grassi alluminio incluso Grease aluminium Filter included

## ACCESSORI ACCESSORIES

Filtro carbone rigenerabile Regenerable charcoal filter	CFC0140423	55,00 €
--	------------	---------

## MODELLI MODELS

TUBE PRO IX/A/43	PRF0080075B	1.073,00 €
TUBE PRO BL MAT/A/43	PRF0090719B	1.073,00 €
TUBE PRO WH MAT/A/43	PRF0090720B	1.073,00 €



# KUADRA

ELICA DESIGN CENTER

43 - 60 cm

Aspirante Duct-out

Acciaio inox

Stainless steel



BACK  
ASPIRATION



LONG LIFE  
FILTER



CM 50



CM 65



Ø150



ENERGY  
CLASS  
(A\*\*/D)

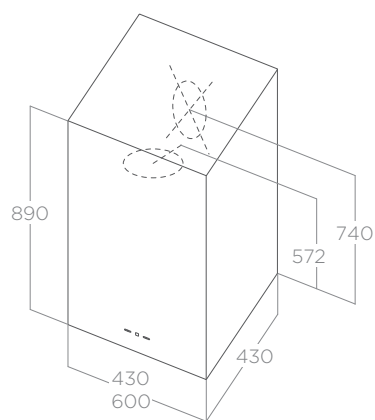

## ILLUMINAZIONE LIGHTING

Tipo Type	Led 2x2,5 W
Intensità Intensity	457 LUX
Temperatura Temperature	2700 K

## PERFORMANCE PERFORMANCE

Comandi Controls	Pulsantiera elettronica con display 3V+I 3S+B Electronic push button with display
Portata intensiva Booster airflow	496 m <sup>3</sup> /h
Livello sonoro min-max Noise level min-max	48 - 62 db(A)
Assorbimento totale Total absorption	256 W

Filtro grassi alluminio incluso Grease aluminium filter included

## ACCESSORI ACCESSORIES

Filtro carbone rigenerabile Regenerable charcoal filter	CFC0140423	55,00 €
--	------------	---------

## MODELLI MODELS

KUADRA IX/A/43	PRF0006491A	1.019,00 €
KUADRA IX/A/60	PRF0007419A	1.073,00 €



# TONDA

DESIGN FABRIZIO CRISÀ

60 - 90 cm

Filtrante Filtering

Acciaio inox

Stainless steel



CM 50



CM 65



Ø150



ENERGY  
CLASS  
(A+++D)

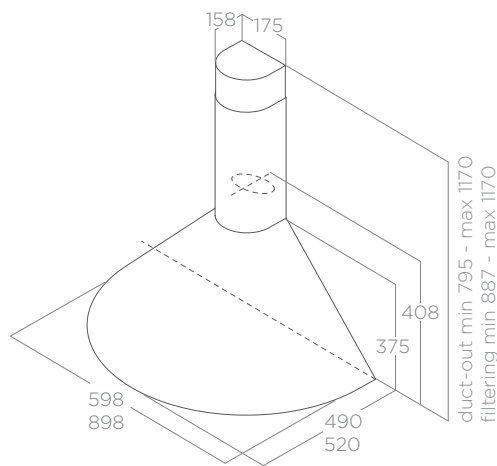

## ILLUMINAZIONE LIGHTING

Tipo Type	Led 2x3 W
Intensità Intensity	97 LUX
Temperatura Temperature	2700 K

## PERFORMANCE PERFORMANCE

Comandi Controls	Slider meccanico 3V 3S Mechanical slider
Portata massima Max airflow	355 m <sup>3</sup> /h
Livello sonoro min-max Noise level min-max	60 - 67 db(A)
Assorbimento totale Total absorption	146 W

**Filtro grassi alluminio incluso** Grease aluminium Filter included  
**Filtro carbone incluso** Charcoal filter included  
**Camino incluso** Chimney included

## ACCESSORI ACCESSORIES

Filtro carbone Charcoal filter	CFC0140124	38,00 €
--------------------------------	------------	---------

## MODELLI MODELS

TONDA IX F/60	2938000C	309,00 €
TONDA IX F/90	2937999C	342,00 €